

SIEMENS

Traveling Wave Tubes

Data Book 1986/87

NRCEI

**Table of Contents
Summary of Types**

Index of Symbols

**Explanation of Technical Data
General Instructions and Operation**

**Power Traveling Wave Tubes
for Radio Link Systems**

**Power Supplies
for Radio Link TWTs**

**High Power TWTs
for Satellite Earth Stations,
TV and Troposcatter Transmitters**

Backward Wave Oscillators

**Siemens Worldwide
(Addresses)**

SIEMENS

Traveling Wave Tubes
Data Book 1986/87



Straightforward ordering with the catalog "Siemens Components Service, Preferred Products".

Every year, a revised edition of the SCS catalog on Preferred Products is published. This catalog comprises preferred products of the entire Siemens components program including their main technical specs.

Orders for components as well as for the above mentioned catalog should be directed to your nearest Siemens Office, Components Division, or Distributor.

**Table of Contents
Summary of Types**

**Published by Siemens AG, Bereich Bauelemente, Vertrieb, Produktinformation,
Balanstraße 73, D-8000 München 80**

For the circuits, descriptions and tables indicated no responsibility is assumed as far as patents or other rights of third parties are concerned.

The information describes the type of component and shall not be considered as assured characteristics. Terms of delivery and rights to change design reserved.

For questions on technology, delivery, and prices please contact the Offices of Siemens Aktiengesellschaft in the Federal Republic of Germany and Berlin (West) or the Siemens Companies and Representatives Worldwide (see list of Siemens Offices).

Table of Contents

	Page
Summary of types	8
Symbols	14
Explanation of technical data	20
Characteristics	20
Operating characteristics	20
Maximum ratings	20
Intermodulation product and 3rd order intercept point	20
General instructions and operation	22
Safety precautions	22
General operating instructions	23
Protective circuit	24
Mounting instructions	24
Heater voltage	25
Preheating time	25
Cooling	26
Environmental conditions	27
Transportation and storage	27
Waveguides and coaxial components	27
Accessory	27
Starting operation	28
Starting operation of traveling wave tube	
RW 2, RW 21, RW 42, RW 80, RW 81	28
RW 70	29
RW 48, RW 48 C, RW 48 M, RW 85	30
RW 88 C, RW 89, RW 89 D, RW 90, RW 90 D, RW 189, RW 248, RW 289	
RW 290, RW 1125, RW 1125 D, RW 1125 G, RW 1127, RW 1136, RW 2135	31
Power TWTs for radio link systems	35
RW 2	36
RW 3	40
RW 21	43
RW 42	46
RW 48	52
RW 48 C	52
RW 48 M	57
RW 70	61
RW 80	65
RW 81	71
RW 85	75
RW 88 C	79
RW 89	83
RW 89 D	83
RW 90	87
RW 90 D	87
RW 189	91
RW 248	95
RW 289	99
RW 290	103

Table of Contents

	Page
RW 1125	107
RW 1125 D	111
RW 1125 G	115
RW 1127	119
RW 1136	123
RW 2135	127
Power supplies for radio link TWTs	132
RWN 120	132
RWN 121	132
RWN 220	140
RWN 221	140
RWN 320	148
RWN 321	148
Control unit BT 300	156
High power TWTs for satellite earth stations, TV and troposcatter transmitters	162
YH 1010	162
YH 1014	169
YH 1020	176
YH 1041	183
YH 1042	189
YH 1043	195
YH 1045	200
YH 1047-A1	205
YH 1047-A2	205
YH 1420	210
XH 1421	215
YH 1422	220
YH 3020	225
YH 3025	230
Backward wave oscillators	236
RWO 35 S	236
RWO 50 S	241
RWO 75 S	246
RWO 110 S	251
RWO 170	256
Siemens worldwide (Addresses)	262

Summary of Types

TWTs for analog and 8 PSK digital radio link systems

Type	f GHz	Application/ Modulation	P ₂ W	V _p dB	k _p %/dB	I _{P₃ max dBm}	Page
RW 89, RW 89 D	5.9... 7.1	A/FM D/8PSK	15 3	40 47	2.5 1.2	45.5 45	83
RW 90, RW 90 D	7.1... 8.5	A/FM D/8PSK	15 3	40 46	3 1.5	45.5 45	87
RW 1125	10.7...11.7	A/FM	22	40	4	45	107
RW 1125 D	10.7...12.7	A/FM D/8PSK	15 3	40 46	3.5 1.5	45 46.5	111
RW 1125 G	10.7...13.2	A/FM	20	41	3.5	45	115

TWTs for 16 QAM digital and single-sideband (SSB) radio link systems

Type	f GHz	Application/ Modulation	P ₂ dBm	V _p dB	k _p %/dB	I _{P₃ max dBm}	Page
RW 189	5.9... 6.4 5.9... 7.1	SSB/AM D/16QAM	30 35	45 42.5	0.3 0.6	49 48	91
RW 1136	10.7...11.7	D/16QAM	35	46	0.8	48	123

TWTs for 64 QAM digital and AM/TV radio link systems

Type	f GHz	Application/ Modulation	P ₂ dBm	V _p dB	k _p %/dB	I _{P₃ max dBm}	Page
RW 248	3.5... 4.2	D/64QAM	36	46	0.4	51	95
RW 289	5.9... 7.1	D/64QAM	36	46	0.4	51	99
RW 290	7.1... 8.5	D/64QAM	36	46	0.4	51	103
RW 2135	10.7...11.7	D/64QAM	36	46	0.5	51	127
RW 1127	11.7...13.2	TV/AM	3.5 ^{*)}	37.5	0.4	51.4	119

*) Video sync. output power in watts

Summary of Types

TWTs for analog radio link systems (for replacement only)

Type	f GHz	P ₂ W	V _p dB	k _p %/dB	Page
RW 2	1.3...2.3	20	40	3.5	36
RW 21	2.4...2.8	20	40	5	43
RW 3	2.4...2.8	5	39	7	40
RW 48, RW 48 C	3.6...4.2	11	39	3	52
RW 42	3.6...4.2	16	39	3.4	40
RW 48 M	4.0...5.0	10	39	3	57
RW 80	5.8...7.0 7.0...8.5	15 10	40 39	5.5 5.5	65
RW 81	5.8...7.0 7.0...8.5	20 15	41 36	3.5 4.5	71
RW 88 C	5.9...6.425	11	39	4	79
RW 85	6.425...7.125	22	39	3	75
RW 70	7.1...8.5	4	37		61

Summary of Types

Power supply units for TWTs

Type	for operation of tube	U_0 rated V	Heat dissipation at	Page
RWN 120	RW 89 D, RW 90 D, RW 1125 D, RW 1125 G	24...60	front	132
RWN 121	RW 89 D, RW 90 D, RW 1125 D, RW 1125 G	24...60	rear	132
RWN 220	RW 189, RW 1136	24...60	front	140
RWN 221	RW 189, RW 1136	24...60	rear	140
RWN 320	RW 248, RW 289, RW 290, RW 1127, RW 2135	24...60	front	148
RWN 321	RW 248, RW 289, RW 290, RW 1127, RW 2135	24...60	rear	148

Summary of Types

TWTs for satellite earth stations

Type	f GHz	P_2 W	V_0 dB	k_p %/dB	Cooling	Page
YH 1047-A1	5.850...6.425	600	46	1.5	forced-air	205
YH 1047-A2	5.850...6.425	700	46	2	forced-air	205
YH 1043	5.925...6.425	1200	33	7	forced-air	195
YH 1041*)	5.925...6.425	3000	33	4	water	183
YH 1042*)	5.925...6.425	3000	33	4	forced-air/water	180
YH 1045	5.925...6.425	8000	34	2.5	water	200
YH 1422	14.0...14.5	300	50	3	forced-air	220
YH 1421	14.0...14.5	600	53	3	forced-air	215
YH 1420	14.0...14.5	2300	48	3	water	210
YH 3025	27.5...29.5	350	50	5	forced-air	230
YH 3020	28.7...30.0	1300	45	5	forced-air/water	225

State-of-the-art Q-band TWTs are available for mobile satellite transmission systems (data upon request).

A pulsed TWT featuring high output power is offered for military radar systems in the S-band (data upon request).

TWTs for TV and troposcatter transmitters (for replacement only)

Type	f MHz	P_2 W	V_0 dB	Cooling	Page
YH 1020	470...860	50**)	25	forced-air	176
YH 1010	470...860	200**)	34	forced-air	162
YH 1014	755...985	600	25	forced-air	169

*) For replacement only

***) Video sync. output power

Summary of Types

Backward wave oscillators

Type	f GHz	P_2 min/typ mW	U_H V	Page
RWO 35 S	23...35	50/150	500...2600	235
RWO 50 S	33...50	30/100	500...2600	241
RWO 75 S	50...75	10/40	500...2600	245
RWO 110 S	75...110	5/20	500...2600	251
RWO 170	110...170	1/10	500...2800	255

Symbols

Symbols

Symbols for electrodes

A, a	Plate
C, c	Collector
F	Heater/filament terminal
F, K	Heater/filament terminal, cathode terminal
F _M	Filament center
G, g	Grid (focusing, accelerating, modulating electrode)
G1, g1	Control grid
G2, g2	Screen grid
H, h	Delay line (helix)
IP, ip	Ion getter pump
I.V.	Internal connection
K, k	Cathode
RES, res	Resonator
RET, ret	Retarding electrode
RFL, rfl	Reflector

Capacitances

C _{gk}	Capacitance grid to plate
C _{g1a}	Capacitance grid 1 to plate
C _{g2a}	Capacitance grid 2 to plate
C _{g1g2}	Capacitance grid 1 to grid 2
C _{kp}	Capacitance cathode to plate
C _{kg}	Capacitance cathode to grid
C _{kg1}	Capacitance cathode to grid 1
C _{kg2}	Capacitance cathode to grid 2
C _{xy}	Capacitance between the electrodes x and y
C _{xyz}	Capacitance of the electrodes x and y with respect to the electrode z
C _i	Input capacitance
C _o	Output capacitance

Currents

I _A	DC plate current
I _{A,Loor}	Zero signal dc plate current
I _{A,M}	Peak plate current
I _{A,p}	Pulse dc plate current
I _{A,RMS}	RMS value of ac plate current
I _{A,SW}	DC plate current, black level
I _{A,SY}	DC plate current, sync. level
I _C	DC collector current
I _{em}	Emission current
I _F	Heater/filament current
I _G	DC grid current
I _{G,Loor}	Zero signal dc grid current
I _{G,M}	Peak grid current
I _{G,p}	Pulse dc grid current
I _{G,RMS}	RMS value of ac grid current

Symbols

Currents (cont'd.)

I _{G1M}	Peak grid 1 current
I _{G1,RMS}	RMS value of ac grid 1 current
I _{G1,SW}	DC grid 1 current, black level
I _{G1,SY}	DC grid 1 current, sync. level
I _{G2}	DC grid 2 current
I _{G2,SW}	DC grid 2 current, black level
I _{G2,SY}	DC grid 2 current, sync. level
I _H	Delay line current (helix)
I _{H,M}	Peak delay line current (helix)
I _{IP}	DC ion getter pump current
I _K	DC cathode current
I _{K,M}	Peak cathode current
I _{K,p}	Pulse dc cathode current
I _o	Direct current, average value
I _{SOL}	Solenoid current

Powers

P _A	Plate dissipation
P _{A,SW}	Plate dissipation, black level
P _{A,SY}	Plate dissipation, sync. level
P _{BA}	Plate input power
P _{BA,SW}	Plate input power, black level
P _{BA,SY}	Plate input power, sync. level
P _{B,G2}	Grid 2 input power
P _C	Collector dissipation
P _F	Heater/filament power
P _G	Grid dissipation
P _{G1}	Grid 1 dissipation
P _{G1,SW}	Grid 1 dissipation, black level
P _{G1,SY}	Grid 1 dissipation, sync. level
P _{G2}	Grid 2 dissipation
P _{G,mod}	Grid dissipation at modulation
P _H	Delay line dissipation (helix)
P _{mod}	Modulation power
P _{SAT}	Saturation power
P _{SCL}	Single-carrier level
P _{sig}	Carrier power
P ₁	Drive power
P _{1,p}	Pulse drive power
P _{1,SW}	Drive power, black level
P _{1,SY}	Drive power, sync. level
P _{1,son}	Drive power, sound
P ₂	Output power
P _{2,p}	Pulse output power
P _{2,SW}	Output power, black level
P _{2,SY}	Output power, sync. level (video sync. output power)

Symbols

Resistances

R_A	Plate load resistance
R_{AA}	Effective load resistance (plate to plate)
r_a	Plate ac resistance
R_{ant}	Antenna resistance
$R_{A\text{ prot}}$	Resistance for plate protection
R_G	Grid resistance
$R_{G\text{ open}}$	Grid resistance (tube not conducting)
R_{G1}	Grid 1 resistance
R_K	Cathode resistance

Voltages

U_A	DC plate voltage
U_{AG}	DC plate to grid voltage
U_{AM}	Peak plate voltage
U_{AO}	Cold dc plate voltage (tube not conducting)
U_{AP}	Plate dc pulse voltage
U_{APD}	Cold dc plate pulse voltage
U_{Am}	Peak ac plate voltage
U_{BA}	DC plate supply voltage
U_{BC}	DC collector supply voltage
U_{BG}	DC grid supply voltage
U_C	DC collector voltage
U_{CO}	Cold dc collector voltage
U_H	Heater/filament voltage
U_P	Preheating voltage
U_{FK}	Heater/filament to cathode voltage
U_G	DC grid voltage (focusing, accelerating, or modulating dc plate voltage)
U_{GM}	Peak ac control grid voltage between grids in push-pull circuitry
U_{GM}	Peak grid voltage
U_{gm}	Peak ac control grid voltage
U_{GD}	DC grid pulse voltage
$U_{G\text{ RMS}}$	RMS value of dc grid voltage
U_{G1}	DC grid 1 voltage
$U_{G1\text{ cut off}}$	Grid 1 cutoff voltage
$U_{G1\text{ fix}}$	DC grid 1 bias, fixed
$U_{G1\text{ SW}}$	DC grid 1 voltage, black level
$U_{G1\text{ SY}}$	DC grid 1 voltage, sync. level
$U_{G1\text{ WB}}$	DC grid 1 voltage, white level
U_{G2}	DC grid 2 voltage
$U_{G2\text{ G3}}$	DC grid 2/grid 3 voltage
U_H	DC delay line voltage (helix)
U_{H0}	DC cold delay line voltage (helix)
U_{IP}	DC ion getter pump voltage
U_{K0}	DC cathode to grid voltage

Symbols

Voltages (cont'd.)

U_{Am}	Peak voltage between cathodes in push-pull circuitry
U_{SOL}	DC solenoid voltage
U_{TR}	Transformer voltage

Miscellaneous

a_{M2}	2-tone intermodulation ratio
a_{M3}	3-tone intermodulation ratio
B	Bandwidth
D	Duty cycle
d_3	3rd order intermodulation product
d_{32}	3rd order intermodulation product, 2 carriers
d_5	5th order intermodulation product
f	Frequency
f_0	Vision carrier frequency
f_{max}	Max. operating frequency
f_p	Pulse repetition frequency
f_{SB}	Sideband frequency
f_{ST}	Interference frequency
f_s	Sound carrier frequency
h	Height above mean sea level
IP_3	3rd order intercept point
K	Feedback factor
k	Total distortion
k_p	AM/PM conversion
m	Modulation factor
NF	Noise figure
P_{rh}	Load reflection
P_{stat}	Static system pressure, absolute
Q	Coolant flow rate
s	Transconductance
S	Voltage standing wave ratio (VSWR)
S_L	Power standing wave ratio (load VSWR)
T_A	Plate temperature
t_{amb}	Ambient temperature
t_C	Collector temperature
t_{case}	Case temperature
t_h	Preheating time
t_{imp}	Pulse duration
t_k	Cathode temperature
t_{stg}	Storage temperature
t_{surf}	Surface temperature
t_i	Inlet temperature
t_o	Outlet temperature
V_p	Power gain
a	Cold loss
Δp	Pressure drop

Symbols

Miscellaneous (cont'd.)

η	Efficiency
η_{osz}	Oscillator efficiency
η_{total}	Total efficiency
μ	Amplification factor
$\mu_{\text{grid 2}}$	μ -factor of grid 2

Explanation of Technical Data
General Instructions and Operation

The data sheets on traveling wave tubes (TWTs) contain the most important technical data. More detailed specifications can be supplied upon request.

Characteristics

Characteristics are to be understood as features describing the type of a tube.

All characteristic data refers to brand-new tubes.

Operating characteristics

The operating characteristics are intended as recommendations for tube operation in typical applications with sensible utilization of the maximum ratings. Unavoidable device deviations, however, result in deviations in the operating characteristics, which have to be considered when designing a circuit. The device deviations are given in the technical specifications.

Maximum ratings

All maximum ratings stated are **absolute values**. They must not be exceeded under any circumstances. Therefore, the circuit must be designed such that during the life of the considered tube and equipment, no maximum rating is exceeded under the worst operating conditions (regarding deviations in supply voltages, in adjustment and spread values of other components, in load, in signal, in environmental conditions, or in tube data). The maximum ratings do not depend on each other; it is, therefore, also impermissible to exceed one maximum rating just because other maximum ratings are not completely utilized. Exceeding only one single maximum rating may damage the tube and any guaranty claim will expire.

Intermodulation product and 3rd order intercept point

A characteristic used for assessing the linearity of amplifiers is the 3rd order intercept point (IP_3).

With dual-carrier measurement IP_3 can be plotted as intersection point of extrapolated single-carrier level ($P_{2\text{SCL}}$) and extrapolated level of a 3rd order intermodulation product ($P_{3\text{IM3}}$) as shown in the diagram on the opposite page.

In the linear range the intermodulation product d_{32} can be calculated for any modulation ($P_{2\text{SCL}}$) from the 3rd order intercept point IP_3 as follows:

$$d_{32} [\text{dB}] = 2 (IP_3 [\text{dBm}] - P_{2\text{SCL}} [\text{dBm}])$$

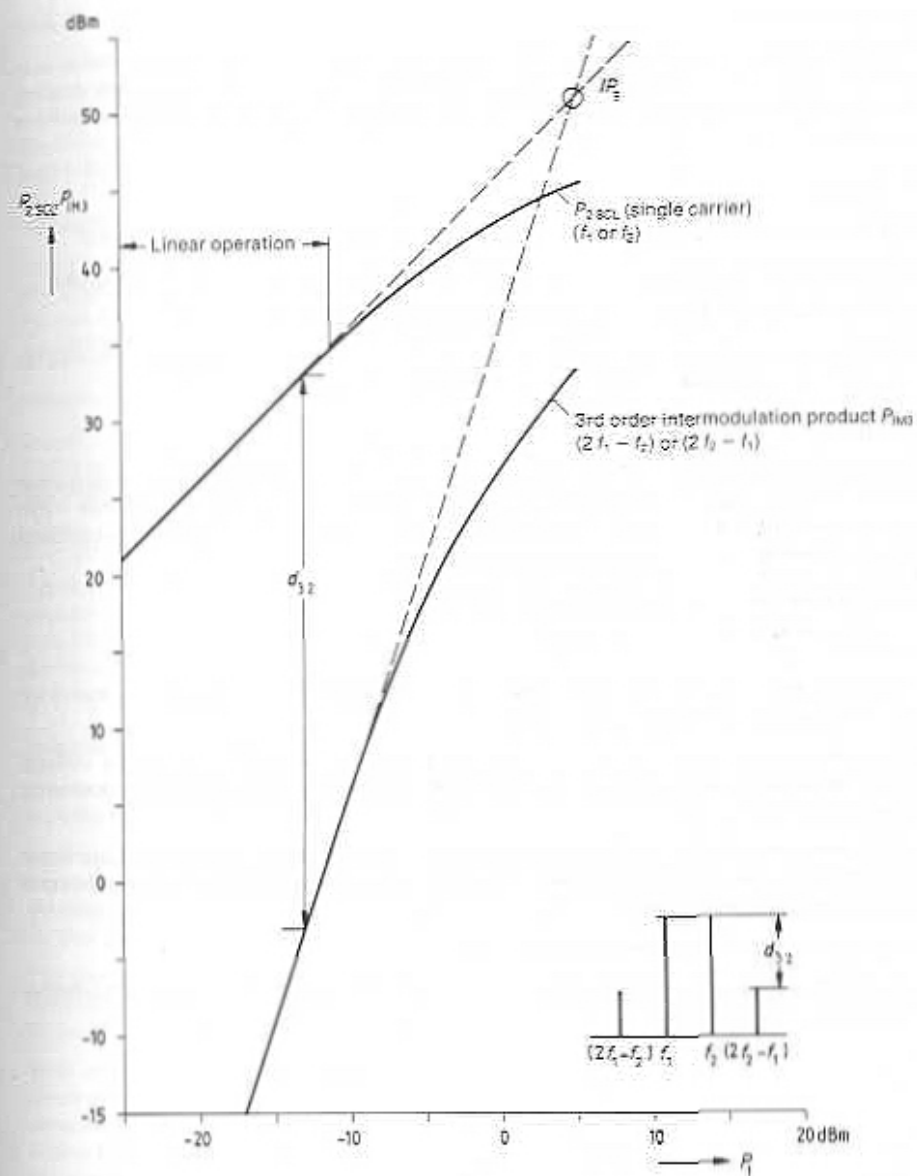

Safety precautions

In case of incorrect handling or operational failures operation of microwave tubes and equipment may involve the hazards described in the following. Any personnel dealing with such equipment should, therefore, be informed about possible dangers and behave accordingly.

High voltage

As TWTs are generally operated at high voltage, the points below are to be considered:

- the relevant safety instructions for work at high-voltage equipment are to be observed
- focusing system and power supply are to be grounded properly
- the tube may only be exchanged with the voltage disconnected. It is advisable to provide for an automatic voltage disconnection including forced grounding of any life part.

RF radiation

RF radiation, harmful to humans, should be as little as possible. Antennas or open waveguides are not to be approached during tube operation. Never look into an open waveguide – eye damage may result! All RF lines must be closed and sealed to RF. The seal should be checked after initial operation as well as after maintenance work.

The relevant national regulations are to be observed.

X-radiation

According to the X-ray regulations, high-vacuum tubes operated at voltages higher than 5 kV are to be regarded as interference radiators.

The occurring X-ray dose rate depends on tube design and maximum operating voltage (consider peak RF voltage!). Measurable dose rates, however, generally appear at operating voltages higher than 20 kV.

The equipment manufacturer should, therefore, provide a proper shielding particularly for tubes with an acceleration voltage greater than 20 kV. During operation it is recommended to check the dose rate periodically.

Test data for the individual tubes is available upon request.

In any case the current national regulations on the protection against X-rays are authoritative for the operation of our tubes.

Beryllia ceramic

Some TWTs from Siemens contain beryllia parts, e.g. for the mechanical support of the helix. As beryllia powder is highly poisonous and may cause grievous injuries to health when breathed in, broken tubes should be handled with utmost caution. Unserviceable tubes may not be disposed of together with ordinary garbage. Siemens will care for the disposal of unserviceable tubes if they are forwarded carriage paid and together with a written order for disposal.

Dielectric gases

Some tubes contain dielectric gases (e.g. Freon, Frigen, SF₆) to assure a seal to microwaves or RF. In case of a gas container damage and under certain conditions, poisonous compounds may be developed. The gases are neither to be breathed in nor should liquids be touched; the environment is to be ventilated adequately!

Implosion

Impermissibly high mechanical stress may cause implosion, for electron tubes are evacuated. Particularly tubes with large vacuum tanks constitute a hazard to operating personnel, as fragments might whirl around.

High temperatures

Tubes and their cooling equipment may develop very high surface temperatures which are still present after the tube has been turned off for quite a while. Touching those hot spots or the coolant in case of a break in the cooling system, may result in burns; appropriate precautions are required.

General operating instructions

Traveling wave tubes, interchangeable within the magnet system, may only be operated in the suitable magnet system. This system is to be grounded properly.

In principle, the heater is to be connected to the cathode, unless there isn't already a connection in the tube. Compared to ground, cathode and heater are on a potential corresponding to the delay line and/or collector voltage, and the heater transformer, therefore, is to be designed for that potential difference.

The electrical operation of the tube is started in the sequence described in section "Starting operation". Voltages for grid 2 must always be applied after (or simultaneously with) the collector voltage.

With certain operational settings, the delay line current/delay line voltage curve of a TWT may show a decreasing delay line current at rising delay line voltage. This causes a negative resistance between delay line and cathode. To obtain a stable operation, it is, therefore, to be considered for the SMPS dimensioning that the dynamic internal resistance in the delay line voltage source is not allowed to exceed the value (for TWTs in radio link applications 20 k Ω) specified in the "Recommendations for SMPS dimensioning".

General Instructions and Operation

Modulation noise may occur when starting the TWT operation after a long storage time. This noise, however, will decrease during the first operating hours and it will have disappeared after further operation.

When stopping the TWT operation, all voltages may be disconnected simultaneously. They may alternatively be disconnected in the sequence described in section "Starting operation", but then the grid 2 and delay line voltages are to be turned off prior to the collector voltage.

Protective circuit

In order to avoid damaging the tube during operation, a protective circuit, for example, is to be provided to turn off the tube as soon as the indicated trip level of the delay line current is exceeded. Also an electronic delay line current limitation can be applied, for which necessary and more detailed information is available upon request. If an independent power source is used for grid 2, an interlock is to be provided to assure immediate disconnection of the grid 2 voltage if the delay line voltage fails or is turned off.

If the collector voltage fails, the delay line and the grid 2 voltage must be disconnected either by the protective circuit located in the delay line supply or by a voltage interlock (the power supplies available for the operation of our TWTs do already include these safety circuits).

For separate cooling, a simultaneous disconnection of all tube supply voltages is to be provided in case of a cooling failure.

Mounting instructions

The tube may only be operated in the permissible mounting position. Magnet systems into which the tubes can be pushed at one of the front sides, should be mounted vertically with this front side up in order to guarantee easy and safe tube replacement. With operation in mobile equipment, the manufacturer should be consulted as regards the optimum mounting position. Here, particularly the cooling instructions should be considered.

The magnet systems are magnet-shielded and insensitive to stray fields. In order to avoid any deterioration of beam focusing, the magnet system should be mounted taking the following protection spacings into account:

RW 2, RW 2i, RW 42, RW 70, RW 80, RW 81

Spacing to iron parts ≥ 50 mm
Spacing to stray fields ≥ 70 mm

General Instructions and Operation

RW 48, RW 48 C, RW 48 M, RW 85

Spacing to large ferromagnetic parts (racks, doors etc.) ≥ 5 mm

Stray fields at the magnet system surface ≤ 40 A/cm

RW 88 C, RW 89, RW 89 D, RW 90, RW 90 D, RW 189, RW 248, RW 289, RW 290, RW 1125, RW 1125 D, RW 1125 G, RW 1127, RW 1136, RW 2135

Spacing to ferromagnetic parts ≥ 10 mm

Spacing between two tubes ≥ 30 mm

External fields at the tube surface

dc field ≤ 20 A/cm

ac field, rms ≤ 0.8 A/cm

The spacings for tubes not listed here, can be read in the specific standards.

The magnet system should be mounted such that no stress will occur.

Moreover, shocks should be avoided. The magnet system and especially the cooler mustn't be modified. Flexible junctions should be used for connecting waveguides or coaxial cables to the tube in order to avoid mechanical stress to the RF terminals.

Heater voltage

The heater voltage has essential influence on the tube life. It is, therefore, to be adjusted to the rated value as exactly as possible. This rated value is principally referred to the heater connection at the tube; the voltage drop in the supply lines is to be considered. The maximum permissible variations of the heater voltage indicated in the data sheets, mustn't be exceeded with respect to the guaranty conditions.

Usually the rated heater voltage may immediately be applied, the inrush current, however, must be limited to the maximum permissible value. The permissible kind of current is indicated for each type. As far as operation with both dc and ac is allowed for MK cathodes, ac is to be preferred. If dc heating is necessary, the plus pole of the heater voltage is to be connected to the cathode.



Preheating time

If specified in the data sheets, the tube is to be preheated with rated heater voltage for the period indicated in the data sheet, before the operating voltages are allowed to be applied. Premature applying of the electrode voltage may cause an overload in the TWT helix, thus damaging or even destroying the tube. After a line failure, turning-on again without preheating is only permitted for a certain maximum interruption time which is specially indicated.

Cooling

The heat developed in the collector and in the delay line of high-power TWTs must be dissipated such that at the reference point the maximum permissible temperature will not be exceeded. The required kind of cooling – conduction, convection, forced-air, water – is indicated in the data sheets. A protective circuit must be provided to turn off the tube in case of a low or failing cooling.

Conduction cooling

The heat developed in the collector is dissipated to air by screwing on a radiator. The conduction cooler mustn't be mechanically overstrained neither during assembly nor during operation. Especially the additional forces caused by thermal expansion have to be taken into consideration as regards dimensioning.

Convection cooling by normal air circulation

The cooler for convection cooling utilizing normal air circulation is provided with a number of cooling fins dissipating the heat to air. The cooler has to be placed such that a good air circulation is guaranteed. If necessary, the air circulation can be improved by using a chimney. It is to be considered that the cooler is contaminated in course of time by the circulating air and that therefore, the efficiency of the cooler will be influenced. For cooler design and arrangement, a reasonable margin between the collector temperature when starting operation and the maximum permissible collector temperature has to be taken into account.

Forced-air cooling

The cooling air diagrams in the data sheets show the minimum air flow rate for a certain collector dissipation and the corresponding pressure drop in the radiator.

Unless otherwise specified, the curves are referred to 1 bar (750 mm Hg).

To avoid cooler contamination and a thereby caused affect on the cooling efficiency it is advisable to filter the cooling air and to clean or exchange that filter at appropriate intervals.

Water cooling

The water inlet and outlet pipes must be insulated if the electrode to be cooled is not grounded. The water flow direction is indicated by arrows at the fittings. Tube damage due to reduced cooling efficiency by mineral deposits is avoided by using distilled and deionized water; this is absolutely required if there is a potential difference between the electrode to be cooled and ground. The use of decalcified water is sufficient, if the electrode to be cooled is on ground potential. It should be assured that the ion exchange filling is always renewed or reactivated in time.

Environmental conditions

Traveling wave tubes – with the exception of satellite earth station tubes – can be used up to an altitude of 3000 m above mean sea level and at a relative humidity of 80 %, unless otherwise specified.

Transportation and storage

The tubes and the magnet systems should principally be transported or stored in their original packings only, which protect them comprehensively against external influences, for example push, shock, dust etc. In case of guaranty claim, the original packing is also to be used when returning the tubes or magnet systems to the manufacturer.

Waveguides and coaxial components

By using commercial junctions, the transition to other waveguide cross sections, flange types, or coaxial connectors is possible.

It is recommended to use isolators at as close a spacing to input and output of the TWTs as possible, which protect the tube against impermissibly high reflections and which also avoid additional noise in the voice channels of radio link systems.

Harmonics, which occur at the output of a TWT due to nonlinearity of the characteristic curves, can be suppressed by filters, for example a low-pass filter.

Accessory

To assure proper tube operation, it is recommended to use only the accessory specified for the tube.

Power supply units are available for state-of-the-art radio link TWTs. In-house development of power supplies is to be based on the operating voltage ranges specified in the data sheets, constituting the necessary minimum ranges.

Starting operation

For the tubes which are not listed in the following instructions, special regulations must be taken into account.

Starting operation of traveling wave tubes RW 2, RW 21, RW 42, RW 80, RW 81

For safety reasons the magnet system must be grounded properly. Tube operation should be started in the following sequence.

Initial operation and tube replacement:

1. Connect the supply leads

Using a shielded high voltage cable, the collector voltage is connected to the tag under the removable cable duct. The helix voltage lead is connected to the grounding tag at the RF output of the magnet system. All other electrode voltages are applied to the tube by the removable connector.

The leads are color-coded as follows:

Heater	F:	brown
Heater	F:	brown-yellow*)
Cathode	K:	yellow*)
Grid 1	G1:	green, red**)
Grid 2	G2:	blue

*) Connect heater to cathode.
**) Connect green and red leads.

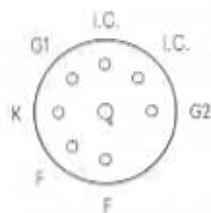

- Insert the tube into the magnet (consider the right position of the slot at the tube base and the pin at the magnet system). Push the connector over the tube base and screw on the coupling ring up to the stop (avoid tilting the connector).
- Apply heater voltage (U_h) and preheat the tube.
- Apply collector voltage (U_c).
- Turn on helix (U_h) and grid 2 (U_{G2}) voltage simultaneously (the time difference between applying both voltages to the electrode should not exceed 0.2 s). Make sure that full voltages are applied immediately and not turned up slowly.
- Set required cathode current (I_k) by adjusting grid 2 voltage (U_{G2}).
- Minimize helix current by adjusting radial and axial field correction rings.
- Apply RF input signal and readjust helix voltage (U_h) to optimum gain or desired output power.
- Repeat field correction according to step 7.

Turning off:

The voltages may be turned off simultaneously or in reverse order to the one indicated in "Initial operation".

Repeated turning on:

Apply all operating voltages and RF signal simultaneously or apply them with their full values in the sequence indicated in "Initial operation".

After operation interruptions up to 10 s, the tube can be turned on without repeated preheating.

Starting operation of traveling wave tube RW 70

For safety reasons the magnet system must be grounded properly. Tube operation should be started in the following sequence.

Initial operation and tube replacement:

1. Connect the supply leads

The helix voltage lead is connected to ground (grounding tag, see outline drawing) of the magnet system. All other electrode voltages are applied to the tube by the supply cable.

The leads are color-coded as follows:

Heater	F:	brown
Heater, cathode	F, K:	yellow
Grid 1	G1:	green
Grid 2	G2:	blue
Collector	C:	red

The safety trip circuit for the power supply is at the line side and controlled by a changeover contact. That contact can be applied after opening the magnet system's cover and unscrewing the 4 screws (a). It is activated by a knurled head screw being tightened or unscrewed at the cover. In addition, a door contact has been provided and closely connected which will apply the grid 1 supply line to the magnet system's ground in case of open cover. The functioning of this contact can be observed through the apertures (b) (see outline drawing).

- Screw bayonet ring at the opening of the system to the right till it stops. Put the tube into the magnet system and consider that the red dot at the tube's face end has to level with the single point marked on the bayonet ring. Insert tube into system till it is arrested (tube can no longer be turned), turn bayonet ring to the left till the two dots on the bayonet ring level with the dot on the tube. Connect plug.
- Apply heater voltage (U_h) and preheat tube for at least 2 minutes.
- Apply the common voltage supply for collector (U_c), helix (U_h), and grid 2 (U_{G2}). Please observe that the voltages are to be applied either immediately with their full values – or, when turning them up slowly, that the ratio between the voltages is equal to the voltage relation during operation. The negative grid 1 voltage is generated via a cathode resistance $R_k = 1,1 \text{ k}\Omega$ (do not fall below the specified value).
- Minimize helix current (I_h) by adjusting grid 2 voltage (U_{G2}).

General Instructions and Operation

6. Release locking lever (see outline drawing) and minimize helix current (I_h) by means of the magnetic field correction. Then tighten locking screw.
7. Apply RF input signal and readjust helix voltage (U_h) to optimum gain or desired output power.
8. Repeat field correction according to step 6.

Turning-off:

The operating voltages are to be turned off simultaneously.

Repeated turning on:

After preheating the tube, apply the common voltage supply for collector, helix, and grid 2, as well as the RF signal.

Starting operation of traveling wave tubes RW 48, RW 48 C, RW 48 M, RW 85

For safety reasons the integrated tube must be grounded properly. Tube operation should be started in the following sequence:

Initial operation:

1. Plug in the high voltage connector.
2. Apply the operating voltages simultaneously or in the following sequence:

Heater voltage
Collector voltage*)
Grid 1 voltage
Helix voltage*)
Grid 2 voltage**)

*) Full voltage values are applied (max rise time 50 ms).

**) U_{G2} has to be applied with its smallest value (potentiometer entirely to the left). If grid 2 voltage is supplied by a separate power supply, the helix voltage must have reached its operational value before grid 2 voltage will be applied.

The RF signal can be applied simultaneously with the operating voltages. The tube is ready for operation after 60 seconds.

3. Adjust cathode current for the required RF output power by means of grid 2 voltage.

Turning off:

The voltages can be turned off simultaneously or in reverse order to the one indicated in "Initial operation".

If the tube is turned off by a high voltage switch located in the grid 2 supply, the following must be taken into account:

- The electrode G2 is to be applied to cathode after turning off grid 2 voltage.

General Instructions and Operation

- To obtain a long service life, the tube should not be operated longer than 1000 hours with $I_c = 0$ (heater in operation) during the test and servicing work.
Standby operation is only permitted with a cathode current flowing.

Repeated turning on:

Apply all operating voltages and RF signal simultaneously or apply them with their full values in the sequence indicated in "Initial operation".

At operation interruptions, the RF signal need not be turned off.

The tube is ready for operation after a period of 60 seconds.

Starting operation of traveling wave tubes RW 85 C, RW 89, RW 89 D, RW 90, RW 90 D, RW 189, RW 248, RW 289, RW 290, RW 1125, RW 1125 D, RW 1125 G, RW 1127, RW 1136 and RW 2135 using the appropriate Siemens power supply

For safety reasons tube and power supply must be grounded properly.

Note: Turn off power supply before exchanging the tube.

For safety reasons it is not possible to turn on the power supply without the tube (interlock circuit).

Initial operation:

1. Set operating voltages for desired tube operation by means of code switch in the power supply.
2. Plug in high voltage connector and establish RF connections.

For tubes RW 88 C, RW 89 and RW 90 the interlock circuit at the tube's connecting cable is to be connected as well.

In order to assure proper RF contacting the RF connectors have to be tightened with the following torque:

N connectors:	min 2	Nm
	max 4	Nm
SMA connectors:	min 0.12	Nm
	nom 0.8 to 1.2	Nm
	max 1.7	Nm

3. Turn potentiometer for grid 2 voltage (cathode current) left to stop
4. Apply supply voltage to power supply.
5. Press reset button.
6. Close standby/transmit switch.

7. After approx. 5 min operating time set desired tube operation.

- a) For **analog operation** set the RF output power at specified RF input power by means of the potentiometer for the grid 2 voltage (cathode current). The maximum permissible cathode and helix current of the tube should not be exceeded.

With tubes RW 88 C, RW 89, RW 89 D, RW 90, RW 90 D, RW 1125, RW 1125 D and RW 1125 G it is possible to set the operating point near the saturation power at two different current ratings (see figure 1); therefore it should be regarded that always the lower current is used for setting. An operating point set incorrectly and thereby causing a considerably higher helix current, impairs efficiency and service life of the tube.

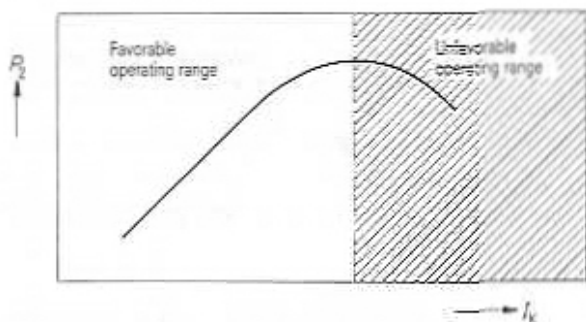

Figure 1

- b) For **digital and AM/TV operation** set the cathode current specified on the tube label by means of the potentiometer for the grid 2 voltage. Subsequently, set the desired RF output power by the RF input signal.

Turning off:

The amplifier is turned off by interrupting the supply voltage.

Repeated turning on:

1. Apply supply voltage.
2. Press reset button.
3. Close standby/transmit switch.
4. After the preheating period of approx. 60 s the amplifier is ready for operation.

Standby operation (during servicing and maintenance periods):

With open standby/transmit switch all voltages – with exception of the grid 2 voltage – remain applied to the tube. After closing the switch the tube is immediately ready for operation.

To ensure long service life the tube should not be operated longer than 1000 h with open standby/transmit switch during servicing and maintenance.

Standby operation of a tube is only permissible with closed standby/transmit switch.

**Power Traveling Wave Tubes
for Radio Link Systems**

For replacement only

Conduction-cooled power TWT for broadband radio link systems with an output power of 20 W in the frequency band 1.7 to 2.3 GHz.

The tube is provided with PPM focusing and with a plug-in match in its associated magnet system.

RW 2 is designed to operate with depressed collector voltage.
The RF power is coupled in and out by way of coaxial connectors.



Traveling wave tube RW 2

Tube base
Weight of tube
Weight of magnet system
Dimensions of magnet system

Dimensions of tube packing
Dimensions of magnet system packing
RF connectors

Mounting position

Ordering code Q41-X3251

special 8 pin type
approx. 150 g net, approx. 920 g gross
approx. 12 kg net, approx. 17 kg gross
approx. 100 mm × 130 mm × 384 mm
(without tube connector)
170 mm × 180 mm × 550 mm
360 mm × 360 mm × 630 mm
50-Ω, N connector 3/7
coax. connector 7/16

any

Heating

Heater voltage	U_H	6.3		V ¹⁾
Heater current	I_H	≈ 0.8		A
Preheating time	t_h	≥ 45		s ²⁾

indirectly heated by ac
metal capillary dispenser cathode

Characteristics ($f = 2.0$ GHz, $I_k = 85$ mA)

		min	nom	max	
Saturation power	P_{SAT}	27	35		W
Small-signal gain	V_p	40	44		dB
Power gain ($P_2 = 20$ W)	V_G	36	40		dB ³⁾
VSWR	s			2.6	⁴⁾
Cold attenuation	α		80		dB

Operating characteristics

Frequency	f	2	2	GHz
Output power	P_2	20	10	W
Power gain	V_p	≈ 40	≈ 37	dB
Collector voltage	U_C	1600	1300	V ⁵⁾
Helix voltage	U_H	1900 ± 200	1850 ± 200	V ⁶⁾
Grid 2 voltage	U_{G2}	600 ± 150	600 ± 150	V ⁶⁾
Grid 1 voltage, negative	$-U_{G1}$	20	40	V ⁶⁾
Helix current	I_H	≈ 3	≈ 1.5	mA
Grid 2 current	I_{G2}	≤ 0.1	≤ 0.1	mA
Cathode current	I_k	85	65	mA ⁶⁾
Noise figure	NF	≈ 26		dB
AM/PM conversion	k_o	≈ 3.5		⁷⁾ dB

All voltages are referred to the cathode.

- ¹⁾ The voltage drop in the heater supply leads must be taken into account. The voltage must be set such that it is exactly 6.3 V at the tube connector. The total voltage drop in the cable is 0.1 V/m. If the maximum variation of the heater voltage exceeds the absolute limits of ± 3 %, the operating performance of the tube will be impaired and its life shortened.
- ²⁾ For initial operation the tube must be preheated > 120 seconds.
- ³⁾ The gain can be changed by altering the cathode current (minimum limit 45 mA). 1 mA cathode current variation causes a gain change of 0.15 dB.
- ⁴⁾ Hot match at tube's input and output throughout the frequency band 1.7 to 2.3 GHz.
- ⁵⁾ Setting values.
- ⁶⁾ The tolerances quoted should be considered when designing the power supply.

Maximum ratings (absolute values)

Cold collector voltage	U_{C0}	max	1900	V
Collector voltage	U_C	max	1800	V
Collector dissipation	P_C	max	150	W
Cold helix voltage	U_{H0}	max	2600	V
Helix voltage	U_H	max	2300	V
Helix voltage	U_H	min	1600	V
Helix current	I_H	max	7	mA ¹⁾
Grid 2 voltage	U_{G2}	max	900	V
Grid 2 dissipation	P_{G2}	max	0.2	W
Grid 1 voltage, negative	$-U_{G1}$	max	100	V
Grid 1 voltage, positive	$+U_{G1}$	max	0	V
Cathode current	I_K	max	100	mA
Load VSWR	S_L	max	2	
Conduction cooler temperature	t	max	115	°C ²⁾
Ambient temperature	t_{amb}	min	-20	°C
Ambient temperature	t_{amb}	max	55	°C
Storage temperature	t_{stg}	min	-40	°C
Storage temperature	t_{stg}	max	70	°C

Traveling wave tube RW 2

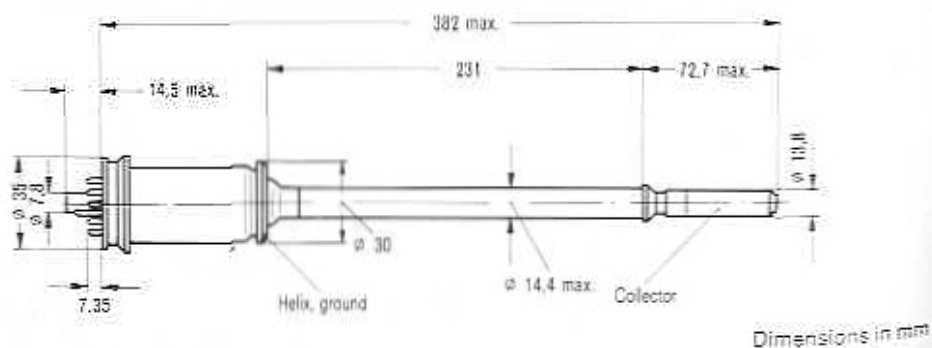

¹⁾ Trip level for helix overcurrent protection circuit.
²⁾ Maximum plate surface temperature of the conduction cooler.

Magnet system MRW 2

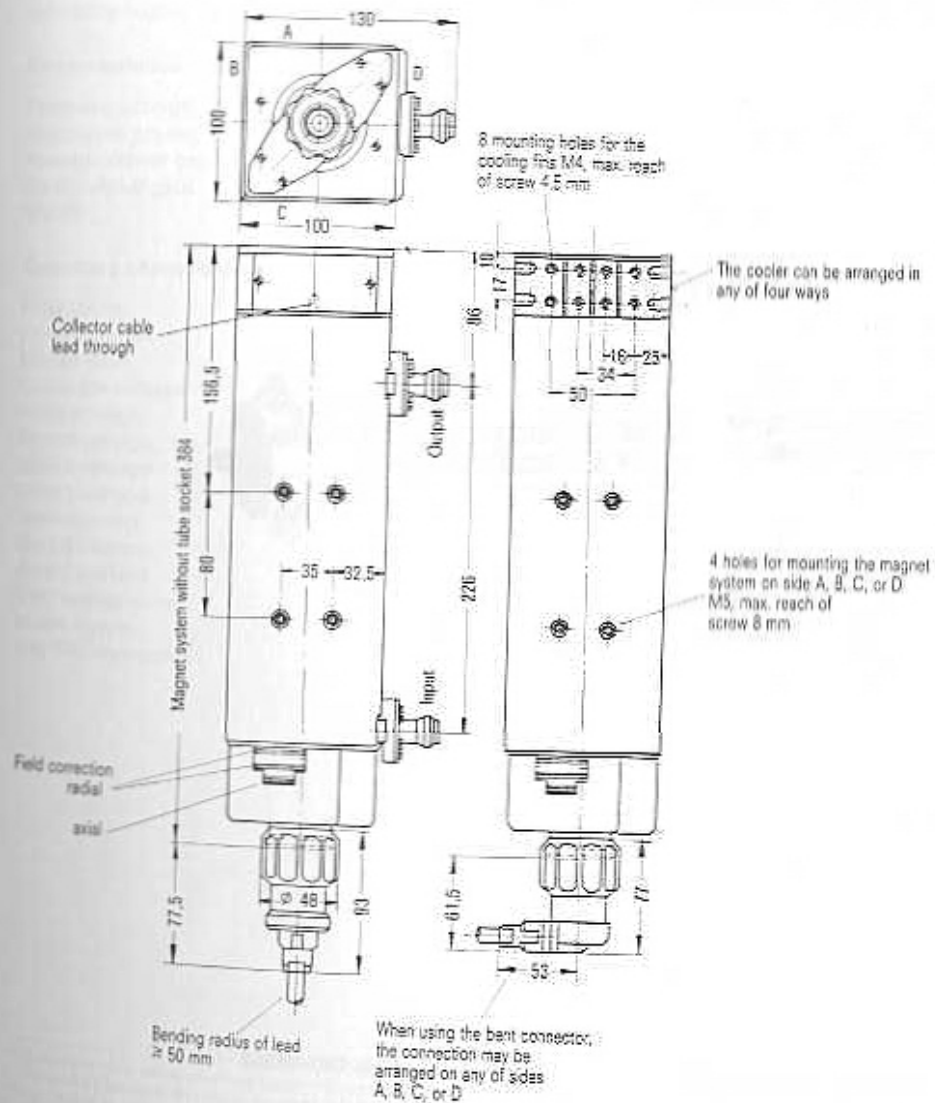

For replacement only

Convection-cooled power TWT for broadband radio link systems with an output power of 5 W in the frequency band 3.3 to 4.3 GHz.

The tube is provided with permanent magnet focusing and with a plug-in match in its associated magnet system. The RF power is coupled in and out by way of waveguides.



Traveling wave tube RW 3

Tube base
Weight of tube
Dimensions of tube packing

Ordering code Q41-X3252

special 8 pin type
approx. 200 g net, approx. 860 g gross
170 mm × 180 mm × 470 mm

Heating

Heater voltage	U_F	6.3 ($\pm 5\%$)	V ¹⁾
Heater current	I_F	1.15 ± 0.12	A
Preheating time indirectly heated by dc	t_h	≥ 120	s

Characteristics

Frequency range	f	3.3 to 4.3	GHz
Saturation power	P_{SAT}	≈ 8	W
Average power gain ($P_2 = 5$ W)	V_p	≈ 39	dB
Small-signal gain	V_p	≈ 40	dB
VSWR	s	1.15	²⁾

Operating characteristics

		min	nom	max	
Frequency	f		4		GHz
Output power	P_2		5		W
Power gain	V_p	35.5	39	42.5	dB
Collector voltage	U_C		1450		V
Helix voltage	U_H		≈ 1350		V
Grid 3 voltage	U_{G3}				V
Grid 2 voltage	U_{G2}		630		V
Grid 1 voltage	U_{G1}		0		V
Helix current	I_H		1.5	2.5	mA
Grid 3 current	I_{G3}		1	2	mA
Grid 2 current	I_{G2}			0.1	mA
Cathode current	I_K	36	40	44	mA
Noise figure	NF		30	33	dB
AM/PM conversion	k_p		7		³⁾ /dB ³⁾

¹⁾ If the maximum variation of the heater voltage exceeds the absolute limits of $\pm 5\%$, the operating performance of the tube will be impaired and its life shortened. Connect -pole with cathode.

²⁾ Best match at tube's input and output throughout the frequency range of 3.3 to 4.3 GHz and ideal adjustment of the RF matching screws to the center frequency with ± 10 MHz bandwidth.

³⁾ AM/PM conversion is the phase shift of the RF output signal when changing the input power by 1 dB.

Maximum ratings (absolute values)

Collector voltage	U_c	max	1550	V
Collector dissipation	P_c	max	70	W
Helix voltage	U_h	max	1500	V
Helix current	I_h	max	3	mA ¹⁾
Grid 3 voltage	U_{g3}	max	1500	V
Grid 3 dissipation	P_{g3}	max	3.5	W
Grid 2 voltage	U_{g2}	max	900	V
Grid 2 dissipation	P_{g2}	max	0.2	W
Grid 1 voltage, negative	$-U_{g1}$	max	500	V
Grid 1 voltage, positive	$+U_{g1}$	max	0	V
Cathode current	I_c	max	50	mA
Collector temperature	t_c	max	180	°C ²⁾

Traveling wave tube RW 3

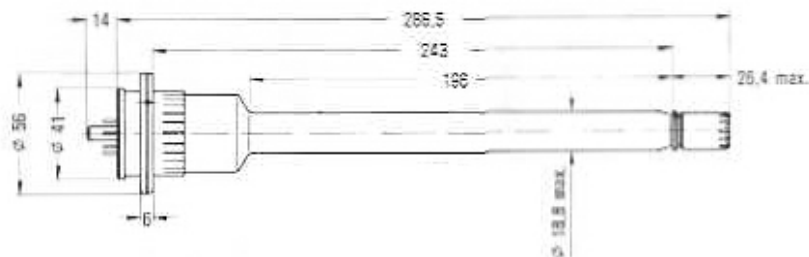

Dimensions in mm

1) The helix current may reach 3.5 mA max. at tube's end of life.

2) The collector temperature may not exceed 150°C.

For replacement only

Conduction-cooled power TWT for broadband radio link systems: with a video synchronous output power of 16 W in the frequency band 2.4 to 2.8 GHz particularly suitable for TV networks.

The tube is provided with PPM focusing and with a plug-in match in its associated magnet system.

RW 21 is designed to operate with depressed collector voltage. The RF power is coupled in and out by way of coaxial connectors.



Traveling wave tube RW 21

Tube base

Weight of tube

Weight of magnet system

Dimensions of magnet system

Dimensions of tube packing

Dimensions of magnet system packing

RF connectors

Mounting position

Ordering code Q41-X3256

special 8 pin type

approx. 150 g net, approx. 920 g gross

approx. 12 kg net, approx. 17 kg gross

approx. 100 mm × 130 mm × 384 mm

(without tube connector)

170 mm × 180 mm × 550 mm

360 mm × 360 mm × 630 mm

50 Ω, N connector 3/7

coax. connector 7/16

any

Heating

Heater voltage	U_H	6.3	V ¹⁾
Heater current	I_H	≈ 0.8	A
Preheating time	t_h	≥ 45	s ²⁾
Indirectly heated by ac metal capillary dispenser cathode.			

Characteristics ($f = 2.6$ GHz, $I_k = 85$ mA)

		min	nom	max	
Pulsed saturation power	$P_{SAT,imp}$	27	32		W
Small-signal gain	V_o	39	42		dB
Power gain ($P_o = 20$ W)	V_o	36	40		dB
VSWR	s			2.6	³⁾
Cold attenuation	a		80		dB

1) The voltage drop in the heater supply leads must be taken into account. The voltage must be set such that it is exactly 6.3 V at the tube connector. The total voltage drop in the cable is 0.1 V/m. If the maximum variation of the heater voltage exceeds the absolute limits of ±3%, the operating performance of the tube will be impaired and its life shortened.
 2) For initial operation the tube must be preheated > 120 s.
 3) Hot match at tube's input and output throughout the frequency band 2.4 to 2.8 GHz.

Operating characteristics I

TV transmitter with combined vision and sound transmission (school TV), negative modulation

	f	2.6	2.6	2.6	GHz
Synchronous output power	$P_{2,sv}$	10	10	16	W
2-tone intermodulation ratio	R_{IM}	≈ 44	≈ 47	≈ 44	dB ¹⁾
Power gain	V_o	≥ 37	≥ 38	≥ 37	dB
Collector voltage	U_c	1600	1500	1500	V
Helix voltage	U_H	≈ 1850	≈ 1850	≈ 1850	V ²⁾
Grid 2 voltage	U_{G2}	≈ 600	≈ 600	≈ 600	V
Grid 1 voltage, negative	$-U_{G1}$	20	20	20	V
Helix current	$I_{H,sv}$	≈ 1	≈ 1.5	≈ 3	mA ³⁾
Grid 2 current	I_{G2}	≤ 0.1	≤ 0.1	≤ 0.1	mA
Cathode current	I_k	85	90	90	mA
Synchronous pulse compression		≤ 30	≤ 20	≤ 30	%

Operating characteristics II

	f	2.6	GHz
Frequency	f	2.6	GHz
Output power	P_o	20	W ⁴⁾
Power gain	V_o	≈ 40	dB
Collector voltage	U_c	1600	V ⁵⁾
Helix voltage	U_H	≈ 1800	V
Grid 2 voltage	U_{G2}	≈ 600	V
Grid 1 voltage, negative	$-U_{G1}$	20	V ⁶⁾
Helix current	I_H	≈ 3	mA
Grid 2 current	I_{G2}	≤ 0.1	mA
Cathode current	I_k	85	mA ⁸⁾
Noise figure	NF	≈ 25	dB
AM/PM conversion	k_o	≈ 5	%/dB ⁹⁾

1) Measured in accordance with specification FTZ 176 P112 of the German Federal Postal Administration with distortion-free input signal.
 2) The helix voltage for maximum small-signal gain is +100 V.
 3) For black level.
 4) The tube is designed to operate at reduced cathode current in applications requiring lower output power. In such cases the manufacturer should be consulted.
 5) Selling values.
 6) AM/PM conversion is the phase shift of the RF output signal when changing the input power by 1 dB.

Level diagram for 1)

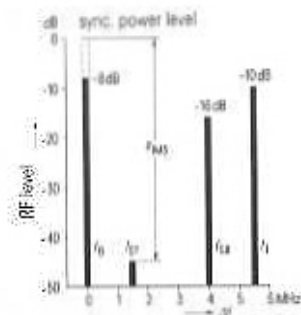

Maximum ratings (absolute values)

Cold collector voltage	U_{C2}	max	1900	V
Collector voltage	U_C	max	1800	V
Collector dissipation	P_C	max	150	W
Cold helix voltage	U_{H2}	max	2600	V
Helix voltage	U_H	max	2200	V
Helix voltage	U_H	min	1600	V
Helix current	I_H	max	7	mA ¹⁾
Grid 2 voltage	U_{G2}	max	900	V
Grid 2 dissipation	P_{G2}	max	0,2	W
Grid 1 voltage, negative	$-U_{G1}$	max	100	V
Grid 1 voltage, positive	$+U_{G1}$	max	0	V
Cathode current	I_c	max	100	mA
Load VSWR	S_L	max	2	
Conduction cooler temperature	t_c	max	115	°C ²⁾
Ambient temperature	t_{amb}	min	-20	°C
Ambient temperature	t_{amb}	max	55	°C
Storage temperature	t_{sto}	min	-40	°C
Storage temperature	t_{sto}	max	70	°C

Traveling wave tube RW 21

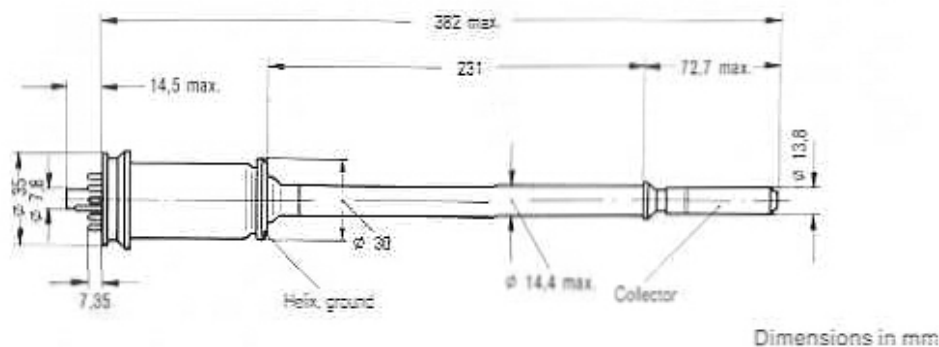

1) Trip level for helix overcurrent protection circuit.
2) Maximum plate surface temperature of the conduction cooler.

Magnet system MRW 21

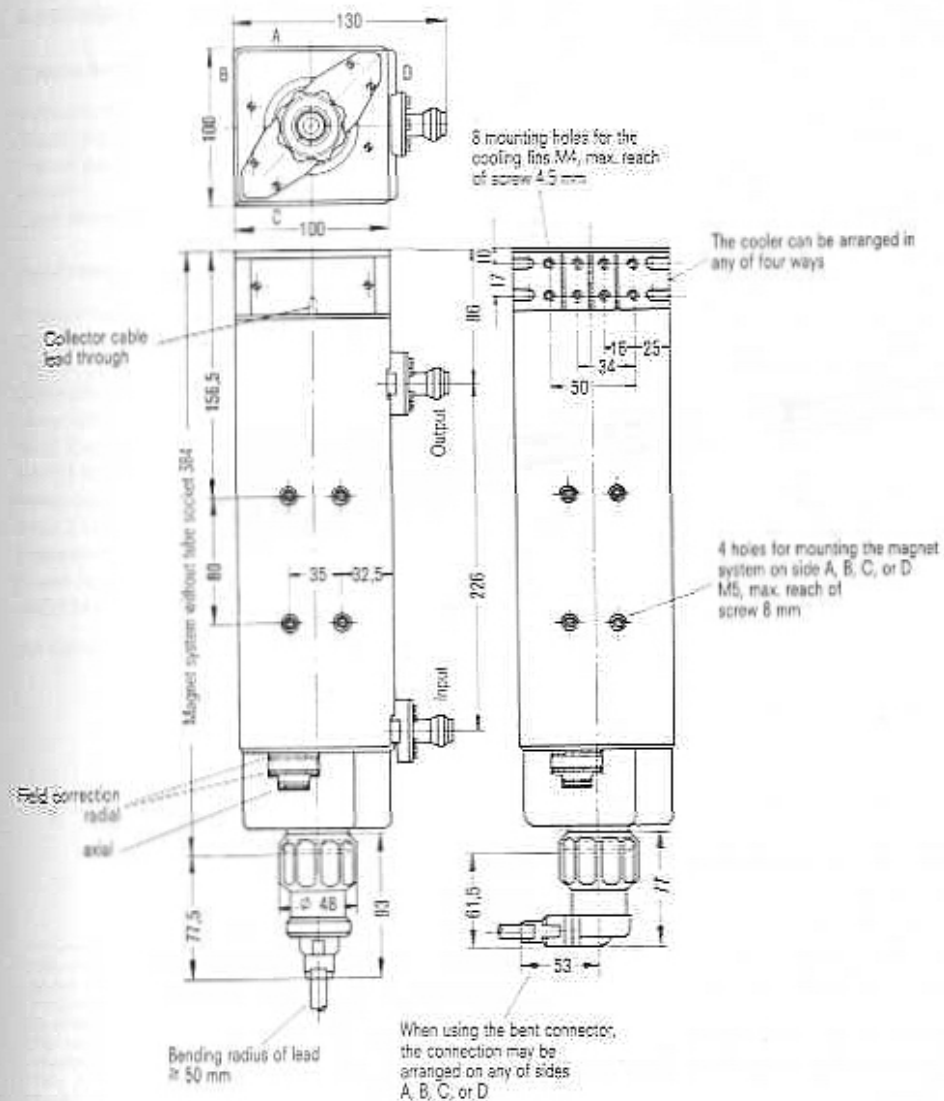

For replacement only

Conduction-cooled power TWT for broadband radio link systems with an output power of 16 W in the frequency band 3.6 to 4.2 GHz.

The tube is provided with PPM focusing and with a plug-in match in its associated magnet system.

RW 42 is designed to operate with depressed collector voltage. The RF power is coupled in and out by way of waveguides.



Traveling wave tube RW 42

Tube base
Weight of tube
Weight of magnet system
Dimensions of magnet system

Dimensions of tube packing
Dimensions of magnet system packing
Waveguide
Flange
Mounting position

Ordering code Q41-X3261

special 8 pin type
approx. 120 g net, approx. 750 g gross
approx. 9 kg net, approx. 14 kg gross
approx. 100 mm × 120 mm × 275 mm
(without tube connector)
170 mm × 180 mm × 470 mm
360 mm × 360 mm × 520 mm
F 40, DIN 47302
UGF 40, DIN 47303
any

Heating

Heater voltage	U_F	6.3	V ¹⁾
Heater current	I_F	≈ 0.8	A
Preheating time	t_h	none	

indirectly heated by ac or dc (+pole to cathode)
metal capillary dispenser cathode

Characteristics ($f = 4.0$ GHz, $I_k = 70$ mA)

		min	nom	max	
Saturation power	P_{SAT}		35		W
Small-signal gain	V_F	38	41		dB
Power gain ($P_2 = 16$ W)	V_G	36	39		dB
VSWR	S			2.1	²⁾
Cold attenuation	α		70		dB

Operating characteristics

Frequency	f	4	4	GHz
Output power	P_2	16	10	W ³⁾
Power gain	V_B	≈ 39	≈ 40	dB
Collector voltage	U_C	1500	1350	V ⁴⁾
Helix voltage	U_H	2400 ± 250	2350 ± 250	V ⁵⁾
Grid 2 voltage	U_{G2}	500 ± 150	500 ± 150	V ⁵⁾
Grid 1 voltage, negative	$-U_{G1}$	20	20	V ⁴⁾
Helix current	I_H	≈ 2	≈ 1.5	mA
Grid 2 current	I_{G2}	≤ 0.1	≤ 0.1	mA
Cathode current	I_k	70	70	mA ⁶⁾
Noise figure	NF	≈ 20		dB
AM/PM conversion	K_P	≈ 3.4	≈ 1.8	⁷⁾ dB ⁸⁾

All voltages are referred to the cathode.

¹⁾ The voltage drop in the heater supply leads must be taken into account. The voltage must be set such that it is exactly 6.3 V ± the tube connector. The total voltage drop in the cable is 0.1 V/m. If the maximum variation of the heater voltage exceeds the absolute limits of ± 3 %, the operating performance of the tube will be impaired and its life shortened.

²⁾ Hot match at tube's input and output throughout the frequency band 3.6 to 4.2 GHz.

³⁾ For tube operation at lower output power levels than 16 W, the cathode current can be reduced by adjusting the grid voltages. However, lower cathode current will cause a reduction in gain and will deteriorate the linear performances of the tube. A change in cathode current by 1 mA in the range 45 to 70 mA causes a change in gain by approx. 0.25 dB.

⁴⁾ Setting values.

⁵⁾ The tolerances quoted should be considered when designing a power supply.

⁶⁾ AM/PM conversion is the phase shift of the RF output signal when changing the input power by 1 dB.

Maximum ratings (absolute values)

Cold collector voltage	U_{CC}	max	3000	V
Collector voltage	U_C	max	1600	V
Collector dissipation	P_C	max	110	W
Cold helix voltage	U_{H0}	max	3200	V
Helix voltage	U_H	max	2700	V
Helix voltage	U_H	min	2000	V
Helix current	I_H	max	6	mA ¹⁾
Grid 2 voltage	U_{G2}	max	700	V
Grid 2 dissipation	P_{G2}	max	0.2	W
Grid 1 voltage, negative	$-U_{G1}$	max	100	V
Grid 1 voltage, positive	$+U_{G1}$	max	0	V
Cathode current	I_K	max	75	mA
Load VSWR	S_L	max	2	
Conduction cooler temperature	t_c	max	115	°C ²⁾
Ambient temperature	t_{amb}	min	-20	°C
Ambient temperature	t_{amb}	max	55	°C
Storage temperature	t_{stg}	min	-40	°C
Storage temperature	t_{stg}	max	70	°C

Traveling wave tube RW 42

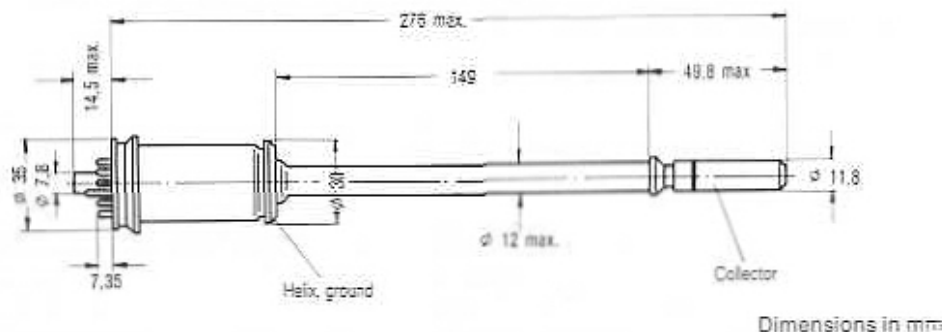

¹⁾ Trip level for helix overcurrent protection circuit.

²⁾ Maximum plate surface temperature of the conduction cooler.

Magnet system MRW 42

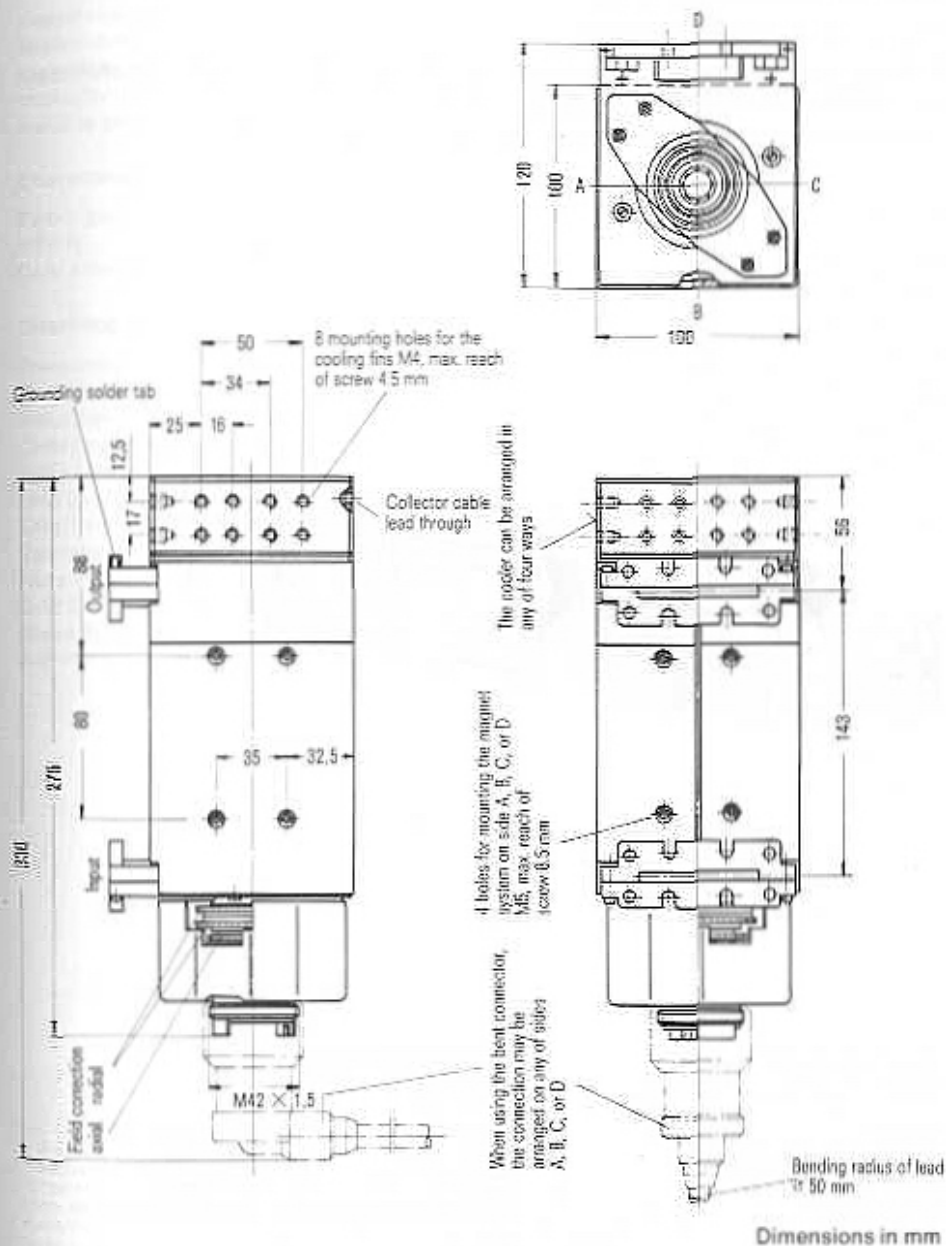

For replacement only

Conduction-cooled power TWT for broadband radio link systems with an output power of 11 W in the frequency band 3.6 to 4.2 GHz.

The tube is provided with PPM focusing.

RW 48 and RW 48 C are designed to operate with depressed collector voltage. The RF power is coupled in and out by way of coaxial connectors.

Types RW 48 and RW 48 C are only different in their electrode connections.

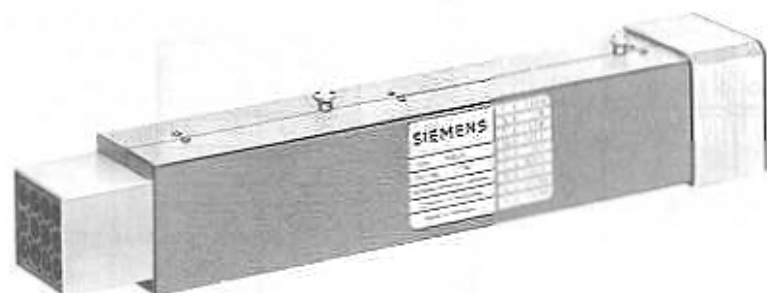

Traveling wave tube RW 48
Traveling wave tube RW 48 C

Weight
Dimensions of tube
Dimensions of packing
RF connector
Mounting position

Ordering code Q41-X3267
Ordering code Q41-X3268

approx. 3.2 kg net, approx. 3.55 kg gross
approx. 60 mm × 60 mm × 360 mm
approx. 140 mm × 140 mm × 450 mm
Siemens coaxial connector 1.4/4.4 (50 Ω)
any

Heating

Heater voltage	U_F	6.3 ± 0.2	V ¹⁾
Heater current	I_F	≈ 0.76	A
Preheating time	t_h	none	

Indirectly heated by ac – also rectangular voltage up to 20 kHz – or dc (+ pole to cathode) metal capillary dispenser cathode.

Characteristics ($f = 3.6 \dots 4.2$ GHz)

		min	nom	max	
Power gain ($P_2 = 11$ W)	V_p		39		dB
VSWR	s			2.1	%)
Cold attenuation	a		80		dB

Operating characteristics

Frequency	f	3.6 ... 4.2	GHz
Output power	P_2	11	W
Input power	P_1	1.4	mW
Collector voltage	U_C	1200	V
Helix voltage	U_H	1800 ... 2100	V ²⁾
Grid 2 voltage	U_{G2}	$U_H - (650 \dots 80 \text{ V})$	V ²⁾ 3)
Grid 1 voltage, negative	$-U_{G1}$	20	V
Cathode current	I_k	30 ... 40	mA ³⁾
Helix current	I_H	≈ 1	mA
Grid 2 current	I_{G2}	$\leq \pm 0.1$	mA
Noise figure	NF	≈ 22	dB
AM/PM conversion	k_a	≈ 3	°/dB ⁴⁾

¹⁾ If the maximum variation of the heater voltage exceeds the absolute limits of ± 0.2 V, the operating performance of the tube will be impaired and its life shortened.

²⁾ The tolerances quoted should be considered when designing the power supply.

³⁾ It is adjusted at a power input of 1.4 mW for a power output of 11 W.

⁴⁾ AM/PM conversion is the phase shift of the RF output signal when changing the input power by 1 dB.

⁵⁾ Flat match at tube's input and output throughout the frequency band 3.6 to 4.2 GHz.

Maximum ratings (absolute values)

Cold collector voltage	U_{C0}	max	2000	V
Collector voltage	U_C	max	1500	V
Collector dissipation	P_C	max	60	W
Cold helix voltage	U_{H0}	max	2800	V
Helix voltage	U_H	max	2500	V
Helix current	I_H	max	4	mA ¹⁾
Grid 2 voltage	U_{G2}	max	2500	V
Grid 2 current	I_{G2}	max	± 0.4	mA
Grid 1 voltage, negative	$-U_{G1}$	min	10	V
Grid 1 voltage, negative	$-U_{G1}$	max	100	V
Cathode current	I_K	max	47	mA
Load reflection	P_{ll}	max	2	W
Conduction cooler temperature	t	max	115	°C ²⁾
Ambient temperature	t_{amb}	min	-20	°C
Ambient temperature	t_{amb}	max	65	°C
Storage temperature	t_{stg}	min	-40	°C
Storage temperature	t_{stg}	max	75	°C
Height above mean sea level		max	4500	m

1) Trip level for helix overcurrent protection circuit.

2) Measured at the temperature reference point (see outline drawing).

Outline drawing RW 48

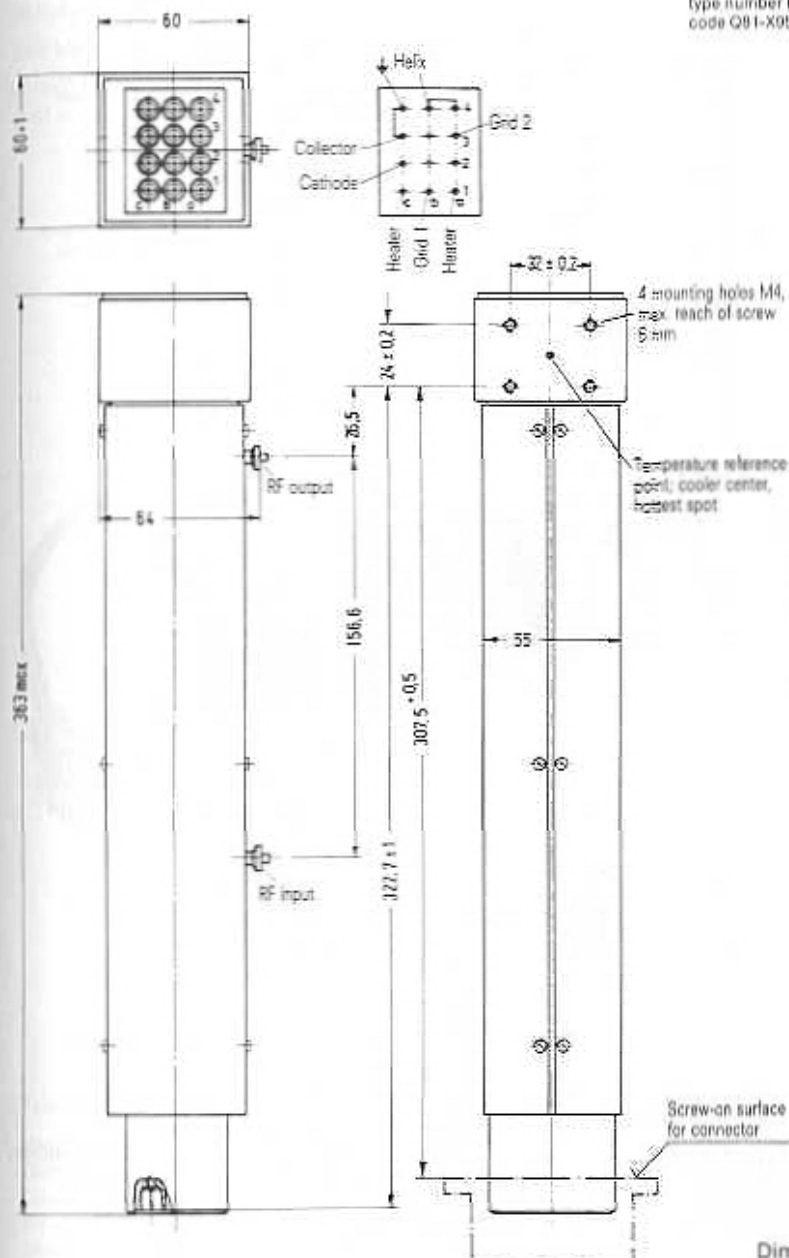

A connector (female) is available, type number RWZ 9635 (ordering code Q91-X0926).

Dimensions in mm

Heating

Heater voltage	U_h	6.3 ± 0.2	V ¹⁾
Heater current	I_h	≈ 0.76	A
Preheating time	t_h	none	

indirectly heated by ac – also rectangular voltage up to 20 kHz – or dc (+ pole to cathode); metal capillary dispenser cathode.

Characteristics ($f = 4.4 \dots 5.0$ GHz)

		min	nom	max	
Power gain ($P_2 = 10$ W)	V_G		38.5		dB
VSWR	s			2.1	°)
Cold attenuation	α		80		dB

Operating characteristics

Frequency	f	4.4 ... 5.0	GHz
Output power	P_2	10	W
Input power	P_1	1.4	mW
Collector voltage	U_C	1200	V
Helix voltage	U_H	1950	V
Grid 2 voltage	U_{G2}	1300 ... 1900	V ²⁾ 3)
Grid 1 voltage, negative	$-U_{G1}$	20	V
Cathode current	I_K	30 ... 45	mA ³⁾
Helix current	I_H	≈ 1	mA
Grid 2 current	I_{G2}	$\leq \pm 0.1$	mA
Noise figure	NF	≈ 22	dB
AM/PM conversion	k_p	≈ 3	%dB ⁴⁾

¹⁾ If the maximum variation of the heater voltage exceeds the absolute limits of ± 0.2 V, the operating performance of the tube will be impaired and its life shortened.

²⁾ The tolerances quoted should be considered when designing the power supply.

³⁾ It is adjusted at a power input of 1.4 mW for a power output of 10 W.

⁴⁾ AM/PM conversion is the phase shift of the RF output signal when changing the input power by 1 dB.

⁵⁾ Hot match at tube's input and output throughout the frequency band 4.4 to 5.0 GHz.

Maximum ratings (absolute values)

Cold collector voltage	U_{CC}	max	2000	V
Collector voltage	U_C	max	1500	V
Collector dissipation	P_C	max	60	W
Cold helix voltage	U_{H0}	max	2800	V
Helix voltage	U_H	max	2500	V
Helix current	I_H	max	4.5	mA ¹⁾
Grid 2 voltage	U_{G2}	max	2500	V
Grid 2 current	I_{G2}	max	± 0.4	mA
Grid 1 voltage, negative	$-U_{G1}$	min	10	V
Grid 1 voltage, negative	$-U_{G1}$	max	100	V
Cathode current	I_K	max	47	mA
Load reflection	P_{r0}	max	2	W
Conduction cooler temperature	t	max	115	°C ²⁾
Ambient temperature	t_{amb}	min	-20	°C
Ambient temperature	t_{amb}	max	65	°C
Storage temperature	t_{stg}	min	-40	°C
Storage temperature	t_{stg}	max	75	°C
Height above mean sea level		max	4500	m

¹⁾ Trip level for helix overcurrent protection circuit.

²⁾ Measured at the temperature reference point (see outline drawing).

Outline drawing RW 48 M

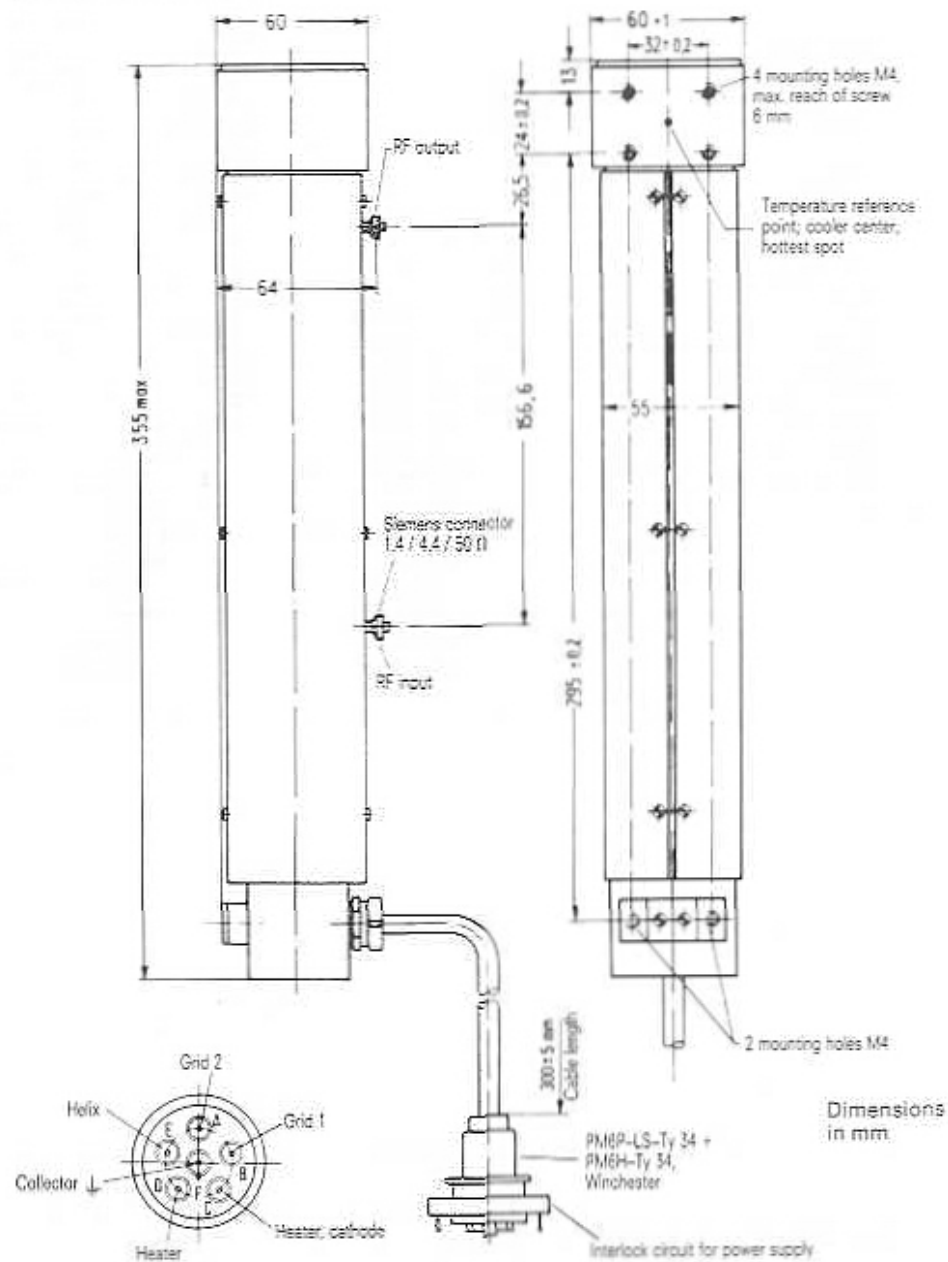

For replacement only

Convection-cooled power TWT for broadband radio link systems with an output power of 4 W in the frequency band 7.1 to 8.5 GHz.

The tube is provided with PPM focusing and with a plug-in match in its associated magnet system.

The RF power is coupled in and out by way of waveguides.



Traveling wave tube RW 70

- Weight of tube
- Weight of magnet system
- Dimensions of magnet system
- Dimensions of tube packing
- Dimensions of magnet system packing
- Waveguide
- Flange
- Mounting position

Ordering code Q41-X3258

- approx. 160 g net, approx. 600 g gross
- approx. 9.8 kg net, approx. 14.7 kg gross
- approx. 130 mm × 140 mm × 240 mm
- approx. 240 mm × 180 mm × 340 mm
- 360 mm × 360 mm × 520 mm
- F 70, DIN 47302
- UGF 70, DIN 47303
- any

Heating

Heater voltage	U_F	6.3	V ¹⁾
Heater current	I_F	≈ 0.4	A
Preheating time	t_h	≥ 120	s
indirectly heated by ac or dc oxide cathode			

Characteristics ($f = 7.5$ GHz, $I_k = 33$ mA)

		min	nom	max	
Pulse saturation power	$P_{SAT imp}$		9		W
Power gain ($P_2 = 4$ W)	V_p	33	37		dB
VSWR	S			2.1	†)
Cold attenuation	α		65		dB

Operating characteristics

Frequency	f	7.5	8.1	GHz
Output power	P_2	4	3.5	W
Power gain	V_c	≈ 37	≈ 36.5	dB
Collector supply voltage	U_{BC}	1700 ± 200	1700 ± 200	V ²⁾
Helix supply voltage	U_{BH}	1700 ± 200	1700 ± 200	V ²⁾
Grid 2 supply voltage	$U_{B G2}$	530 ± 100	530 ± 100	V ²⁾
Cathode resistance	R_k	1.1	1.1	kΩ ³⁾
Helix current	I_H	≈ 1.5	≈ 1.5	mA
Grid 2 current	I_{G2}	≤ 0.1	≤ 0.1	mA
Cathode current	I_k	≈ 33	≈ 33	mA

¹⁾ The voltage drop in the heater supply leads must be taken into account. The voltage must be set such that it is exactly 6.3 V at the tube. The total drop in the cable is 0.05 V/m. If the maximum of the heater voltage exceeds the absolute limits of ± 5 %, the operating performance of the tube will be impaired and its life shortened.

²⁾ Hot matches at tube's input and output throughout the frequency band 7.1 to 8.5 GHz.

³⁾ The tolerances quoted should be considered when designing the power supply.

⁴⁾ Grid 1 voltage about -35 V to -40 V.

Maximum ratings (absolute values)

Collector voltage	U_C	max	1900	V
Collector dissipation	P_C	max	70	W
Helix voltage	U_H	max	1900	V
Helix current	I_H	max	4	mA ¹⁾
Grid 2 voltage	U_{G2}	max	600	V
Grid 1 voltage, negative	$-U_{G1}$	max	100	V
Grid 1 voltage, positive	$+U_{G1}$	max	0	V
Cathode current	I_k	max	40	mA
Load VSWR	S_L	max	2	
Conduction cooler temperature	t_c	max	120	°C ²⁾
Ambient temperature	t_{amb}	min	-20	°C
Ambient temperature	t_{amb}	max	55	°C
Storage temperature	t_{stg}	min	-40	°C
Storage temperature	t_{stg}	max	70	°C

Traveling wave tube RW 70

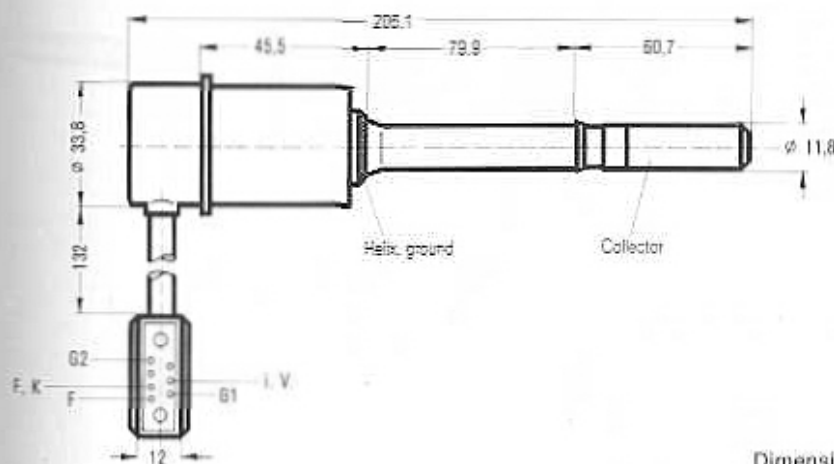

Dimensions in mm

¹⁾ Trip level for helix overcurrent protection circuit.

²⁾ Measured at the temperature reference point (see outline drawing).

Magnet system MRW 70

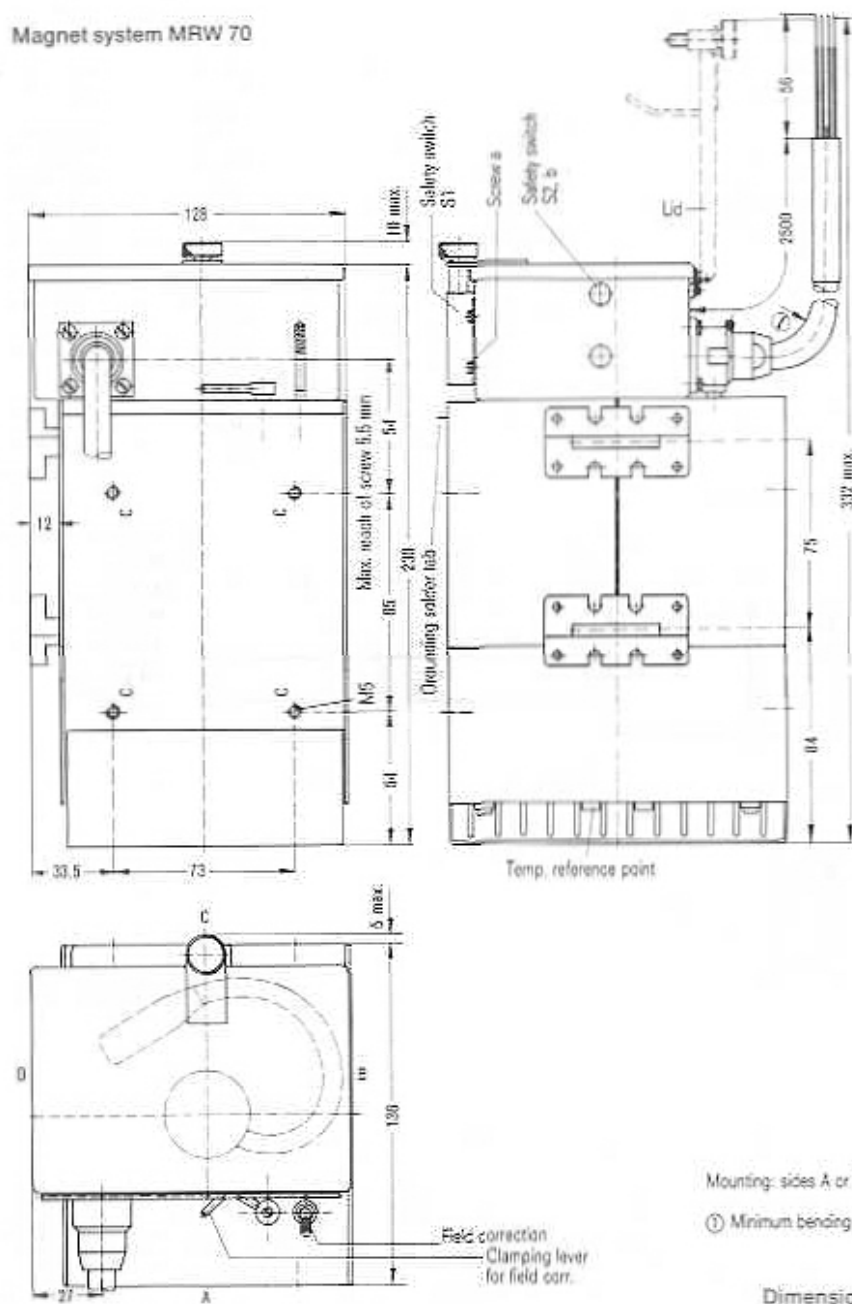

Mounting: sides A or C

① Minimum bending radius 50 mm

Dimensions in mm

For replacement only

Conduction-cooled power TWT for broadband radio link systems in the frequency band 5.8 to 8.5 GHz with an output power of 15 W in the band 5.8 to 7 GHz and of 10 W up to 8.5 GHz.

The tube is provided with PPM focusing and with a plug-in match in its associated magnet system.

RW 80 is designed to operate with depressed collector voltage. The RF power is coupled in and out by way of waveguides.



Traveling wave tube RW 80

Tube base

Weight of tube

Weight of magnet system

Dimensions of magnet system

Dimensions of tube packing

Dimensions of magnet system packing

Waveguide

Flange

Mounting position

Ordering code Q41-X3259

special 8 pin type

approx. 120 g net, approx. 750 g gross

approx. 8 kg net, approx. 12.8 kg gross

100 mm × 112 mm × 264 mm

(without tube connector)

170 mm × 180 mm × 470 mm

360 mm × 360 mm × 520 mm

F 70, DIN 47302

UGF 70, DIN 47303

any

Heating

Heater voltage	U_r	6.3	V ¹⁾
Heater current	I_r	≈ 0.8	A
Preheating time	t_h	none	
indirectly heated by ac or dc (+ pole to cathode) metal capillary dispenser cathode			

Characteristics I ($f = 6.0$ GHz, $I_k = 50$ mA)

		min	nom	max	
Pulse saturation power	$P_{SAT imp}$	22	30		W
Small-signal gain	V_o	38	42		dB
Power gain ($P_2 = 15$ W)	V_o	36	40		dB
VSWR	s			2.1	²⁾
Cold attenuation	c		70		dB

Characteristics II ($f = 8.0$ GHz, $I_k = 50$ mA)

		min	nom		
Pulse saturation power	$P_{SAT imp}$		18		W
Small-signal gain	V_o	35	39		dB
Power gain ($P_2 = 10$ W)	V_o	33	37		dB
Cold attenuation	c		70		dB

Operating characteristics ($f = 6.0$ GHz, $I_k = \text{constant}$)

		15	10	5	
Output power	P_o				W
Power gain	V_o	≈ 40	≈ 41	≈ 41.5	dB
Collector voltage	U_c	1500	1300	1200	V ¹⁾
Helix voltage	U_H	2900 ± 250	2900 ± 250	2900 ± 250	V ²⁾
Grid 2 voltage	U_{G2}	550 ± 120	550 ± 120	550 ± 120	V ²⁾
Grid 1 voltage, negative	U_{G1}	40	40	40	V ³⁾
Cathode current	I_k	50	50	50	mA ²⁾ ³⁾
Helix current	I_H	≈ 1.5	≈ 1	≈ 1	mA
Grid 2 current	I_{G2}	≤ ± 0.1	≤ ± 0.1	≤ ± 0.1	mA
Noise figure	NF	≈ 22	≈ 22	≈ 22	dB
AM/PM conversion	k_s	≈ 5	≈ 3	≈ 1.5	%/dB ⁴⁾

¹⁾ The voltage drop in the heater supply leads must be taken into account. The voltage must be set such that it is exactly 6.3 V at the tube connector. The total voltage drop in the cable is 0.1 V/m. If the maximum variation of the heater voltage exceeds the absolute limits of ± 3 %, the operating performance of the tube will be impaired and its life shortened.

²⁾ Hot match at tube's input and output throughout the frequency band 5.8 to 6.6 GHz.

³⁾ Setting values.

⁴⁾ The tolerances quoted should be considered when designing a power supply.

⁵⁾ A variation of 1 mA cathode current in the range 48 to 52 mA causes a change in gain of approximately 0.5 dB.

⁶⁾ AM/PM conversion is the phase shift of the RF output signal when changing the input power by 1 dB.

Operating characteristics ($f = 6.0$ GHz, $P_1 = \text{constant}$)

		15	10	5	
Output power	P_o				W
Input power	P_1	3	2	2	mW
Collector voltage	U_c	1500	1300	1200	V ¹⁾
Helix voltage	U_H	2900 ± 250	2900 ± 250	2850 ± 250	V ²⁾
Grid 2 voltage	U_{G2}	550 ± 120	550 ± 120	500 ± 120	V ²⁾
Grid 1 voltage, negative	$-U_{G1}$	40	60	80	V ¹⁾
Cathode current	I_k	≈ 45	≈ 45	≈ 40	mA
Helix current	I_H	≈ 1.5	≈ 1.0	≈ 1.0	mA
Grid 2 current	I_{G2}	≤ ± 0.1	≤ ± 0.1	≤ ± 0.1	mA
Noise figure	NF	≈ 22	≈ 22	≈ 22	dB
AM/PM conversion	k_s	≈ 5.5	≈ 3.5	≈ 2.5	%/dB ⁴⁾

Operating characteristics ($f = 7.0$ GHz, $I_k = \text{constant}$)

		15	10	5	
Output power	P_o				W
Power gain	V_o	≈ 39.5	≈ 40.5	≈ 41	dB
Collector voltage	U_c	1450	1300	1200	V ¹⁾
Helix voltage	U_H	2850 ± 250	2850 ± 250	2850 ± 250	V ²⁾
Grid 2 voltage	U_{G2}	550 ± 120	550 ± 120	550 ± 120	V ²⁾
Grid 1 voltage, negative	$-U_{G1}$	40	40	40	V ¹⁾
Cathode current	I_k	50	50	50	mA ¹⁾ ³⁾
Helix current	I_H	≈ 1.5	≈ 1	≈ 1	mA
Grid 2 current	I_{G2}	≤ ± 0.1	≤ ± 0.1	≤ ± 0.1	mA
Noise figure	NF	≈ 22	≈ 22	≈ 22	dB

Operating characteristics ($f = 8.4$ GHz, $I_k = \text{constant}$)

		10	5		
Output power	P_o				W
Power gain	V_o	≈ 37.5	≈ 38		dB
Collector voltage	U_c	1300	1200		V ¹⁾
Helix voltage	U_H	2800 ± 250	2800 ± 250		V ²⁾
Grid 2 voltage	U_{G2}	550 ± 120	550 ± 120		V ²⁾
Grid 1 voltage, negative	$-U_{G1}$	40	40		V ¹⁾
Cathode current	I_k	50	50		mA ¹⁾ ³⁾
Helix current	I_H	≈ 1.5	≈ 1		mA
Grid 2 current	I_{G2}	≤ ± 0.1	≤ ± 0.1		mA
Noise figure	NF	≈ 22	≈ 22		dB

All voltages are referred to the cathode.

¹⁾ Setting values.

²⁾ The tolerances quoted should be considered when designing a power supply.

³⁾ A variation of 1 mA cathode current in the range 48 to 52 mA causes a change in gain of approximately 0.5 dB.

⁴⁾ AM/PM conversion is the phase shift of the RF output signal when changing the input power by 1 dB.

Maximum ratings (absolute values)

Cold collector voltage	U_{c0}	max	3000	V
Collector voltage	U_c	max	1600	V
Collector dissipation	P_c	max	80	W
Cold helix voltage	U_{u0}	max	4000	V
Helix voltage	U_u	max	3200	V
Helix voltage	U_u	min	2400	V
Helix current	I_u	max	5	mA ¹⁾
Grid 2 voltage	U_{g2}	max	700	V
Grid 2 current	I_{g2}	max	± 0.4	mA
Grid 1 voltage, negative	$-U_{g1}$	max	100	V
Grid 1 voltage, positive	$+U_{g1}$	max	0	V
Cathode current	I_k	max	55	mA
Load VSWR	S_{11}	max	2	
Conduction cooler temperature	t	max	115	°C ²⁾
Ambient temperature	t_{amb}	min	-20	°C
Ambient temperature	t_{amb}	max	55	°C
Storage temperature	t_{stg}	min	-40	°C
Storage temperature	t_{stg}	max	70	°C

Traveling wave tube RW 80

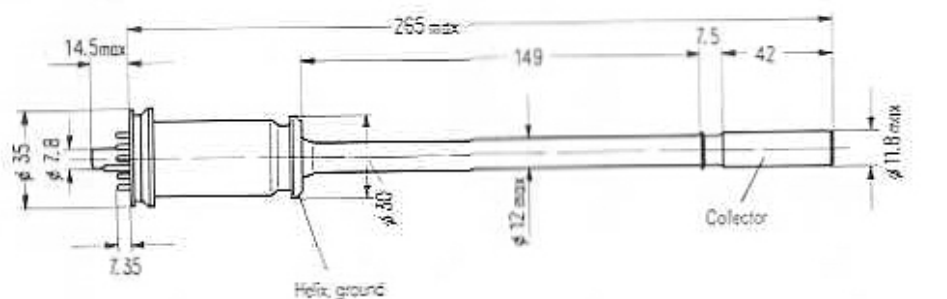

Dimensions in mm

¹⁾ Trip level for helix overcurrent protection circuit.

²⁾ Maximum plate surface temperature of the conduction cooler.

Magnet system MRW 80

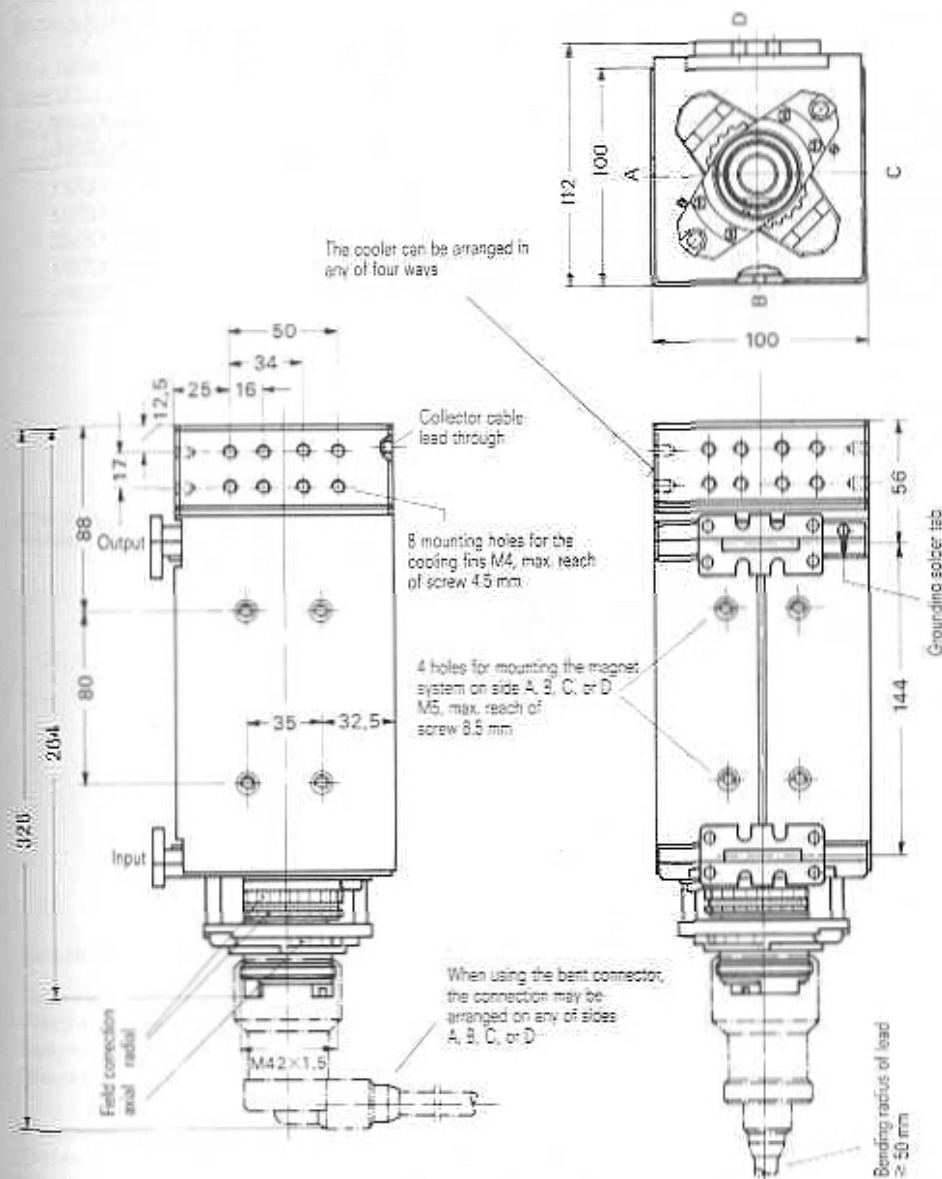

Dimensions in mm

Accessories

Type	Design		Ordering code
	Cooler arrangement at side	Collector connection at side	
Magn. system MRW 80a21	A, B, and C	D	Q43-X2362
Magn. system MRW 80a22	A, C, and D	B	Q43-X2366
Connector cable RWZ 9430	axial	} standard cable length 1.2 m	Q81-X2321
Connector cable RWZ 9431	bent in direction A		Q81-X2322
Connector cable RWZ 9432	bent in direction B		Q81-X2323
Connector cable RWZ 9433	bent in direction C		Q81-X2324
Connector cable RWZ 9434	bent in direction D		Q81-X2325

For replacement only

Conduction-cooled power TWT for broadband radio link systems and preamplifiers (IPA) for satellite earth stations in the frequency band 5.8 to 8.5 GHz. The output power is 20 W in the frequency band 5.8 to 7 GHz and 15 W up to 8.5 GHz, respectively.

The tube is provided with PPM focusing and with a plug-in match in its associated magnet system.

RW 81 is designed to operate with depressed collector voltage. The RF power is coupled in and out by way of waveguides.



Traveling wave tube RW 81

Tube base
Weight of tube
Weight of magnet system
Dimensions of magnet system

Dimensions of tube packing
Dimensions of magnet system packing
Waveguide
Flange
Mounting position

Ordering code Q41-X3259

special 8 pin type
approx. 120 g net, approx. 750 g gross
approx. 8 kg net, approx. 12.8 kg gross
100 mm × 112 mm × 264 mm
(without tube connector)
170 mm × 180 mm × 470 mm
360 mm × 360 mm × 520 mm
F 70, DIN 47302
UGF 70, DIN 47303
any

Heating

Heater voltage	U_F	6.3	V ¹⁾
Heater current	I_F	≈ 0.8	A
Preheating time	t_h	none	

Indirectly heated by ac or dc (+ pole to cathode)
metal capillary dispenser cathode.

Characteristics ($f = 6.0$ GHz, $I_k = 65$ mA)	min	nom	max	
Pulse saturation power	$P_{SAT-imp}$	27	35	W
Small-signal gain	V_p	38	42	dB
Power gain ($P_2 = 20$ W)	V_p	37	41	dB ²⁾
VSWR	S		2.1	²⁾
Cold attenuation	α		70	dB

Operating characteristics ($f = 6.0$ GHz)

Output power	P_2	20	10	W
Power gain	V_p	≈ 41	≈ 42	dB
Collector voltage	U_C	1600	1300	V ³⁾
Helix voltage	U_H	2950 ± 250	2920 ± 250	V ⁴⁾
Grid 2 voltage	U_{G2}	700 ± 200	700 ± 200	V ⁴⁾
Grid 1 voltage, negative	$-U_{G1}$	50	50	V ³⁾
Cathode current	I_k	65	65	mA ³⁾
Helix current	I_H	≈ 2	≈ 1.5	mA
Grid 2 current	I_{G2}	≤ ± 0.1	≤ ± 0.1	mA
Noise figure	NF	≈ 22	≈ 22	dB
AM/PM conversion	k_p	≈ 3.5	≈ 2	°/dB ⁴⁾

Operating characteristics ($f = 8.0$ GHz)

Output power	P_2	15	10	W
Power gain	V_p	≈ 36	≈ 36.5	dB
Collector voltage	U_C	1500	1400	V ³⁾
Helix voltage	U_H	2850 ± 250	2850 ± 250	V ⁴⁾
Grid 2 voltage	U_{G2}	750 ± 200	750 ± 200	V ⁴⁾
Grid 1 voltage, negative	$-U_{G1}$	50	50	V ³⁾
Cathode current	I_k	65	65	mA ³⁾
Helix current	I_H	≈ 2	≈ 1.5	mA
Grid 2 current	I_{G2}	≤ ± 0.1	≤ ± 0.1	mA
Noise figure	NF	≈ 22	≈ 22	dB
AM/PM conversion	k_p	≈ 4.5	≈ 2.5	°/dB

All voltages are referred to the cathode.

¹⁾ The voltage drop in the heater supply leads must be taken into account. The voltage must be set such that it is exactly 6.3 V at the tube connector. The total voltage drop in the cable is 0.1 V/m. If the maximum variation of the heater voltage exceeds the absolute limits of ± 3%, the operating performance of the tube will be impaired and its life shortened.

²⁾ Hot match at tube's input and output throughout the frequency band 5.8 to 8.5 GHz.

³⁾ Settling values.

⁴⁾ The tolerances quoted should be considered when designing a power supply.

⁵⁾ The gain may be reduced by changing the cathode current. 1 mA cathode current variation causes a change in gain of approximately 0.25 dB.

⁶⁾ AM/PM conversion is the phase shift of the RF output signal when changing the input power by 1 dB.

Maximum ratings (absolute values)

Cold collector voltage	U_{C0}	max	3000	V
Collector voltage	U_C	max	1700	V
Collector dissipation	P_C	max	110	W
Cold helix voltage	U_{H0}	max	4000	V
Helix voltage	U_H	max	3200	V
Helix voltage	U_H	min	2400	V
Helix current	I_H	max	5	mA ¹⁾
Grid 2 voltage	U_{G2}	max	1000	V
Grid 2 current	I_{G2}	max	± 0.4	mA
Grid 1 voltage, negative	$-U_{G1}$	max	100	V
Grid 1 voltage, positive	$+U_{G1}$	max	0	V
Cathode current	I_k	max	70	mA
Load VSWR	S_L	max	2	
Conduction cooler temperature	t	max	115	°C ²⁾
Ambient temperature	t_{amb}	min	-20	°C
Ambient temperature	t_{amb}	max	55	°C
Storage temperature	t_{stg}	min	-40	°C
Storage temperature	t_{stg}	max	70	°C

Traveling wave tube RW 81

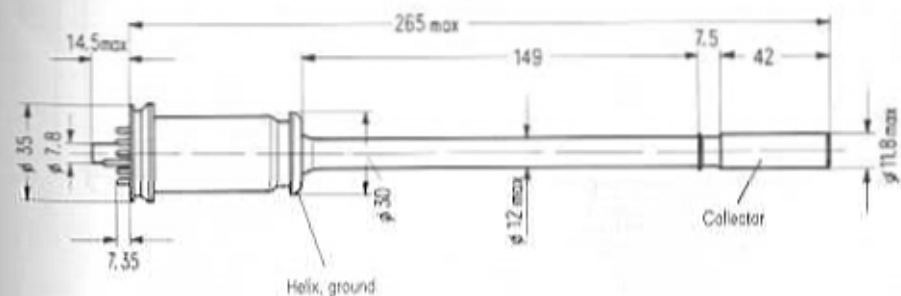

Dimensions in mm

¹⁾ Trip level for helix overcurrent protection circuit.

²⁾ Maximum plate surface temperature of the conduction cooler.

Magnet system MRW 81

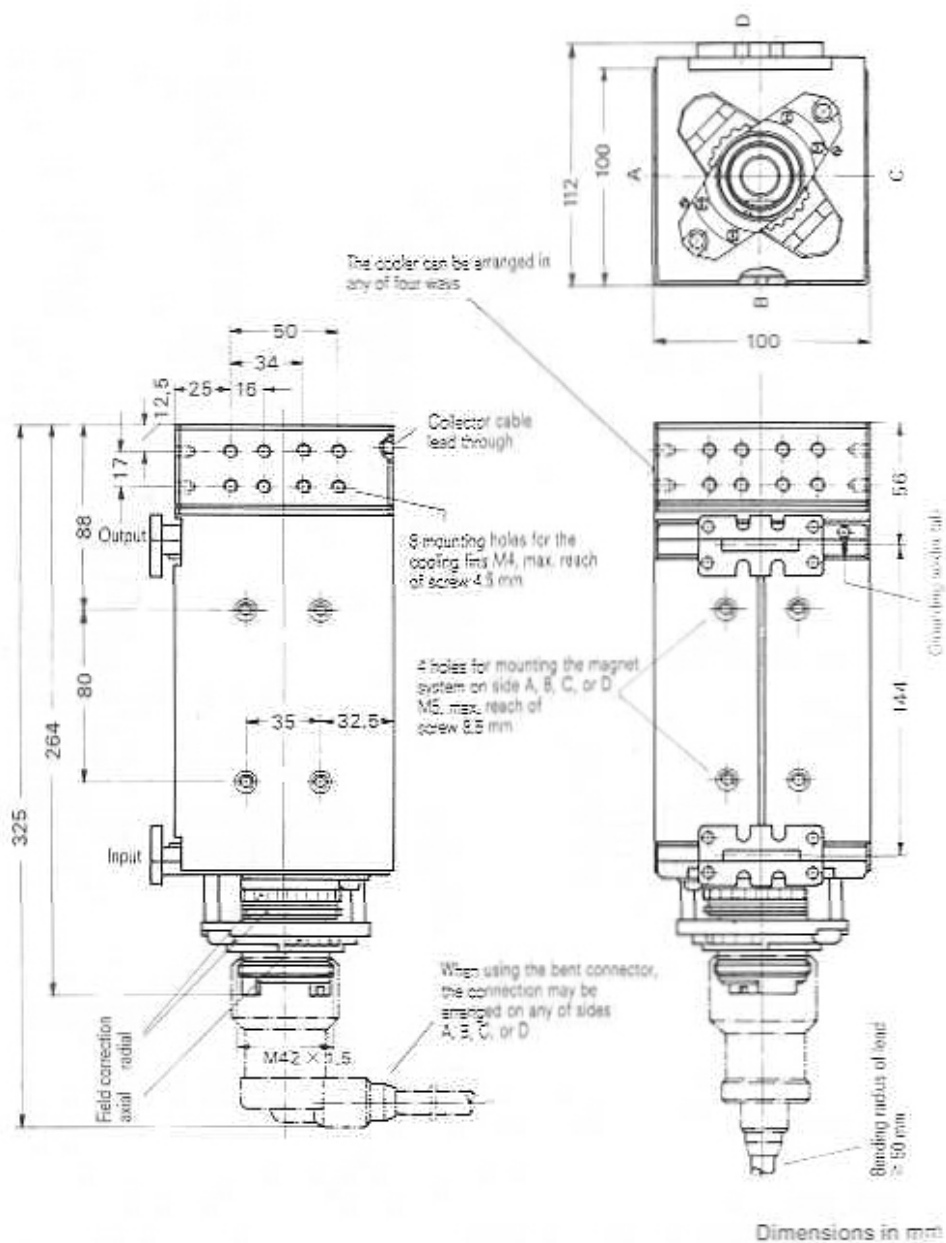

For replacement only

Conduction-cooled power TWT for broadband radio link systems with an output power of 22 W in the frequency band 6.425 to 7.125 GHz.

The tube is provided with PPM focusing.

RW 85 is designed to operate with depressed collector voltage. The RF power is coupled in and out by way of coaxial connectors.

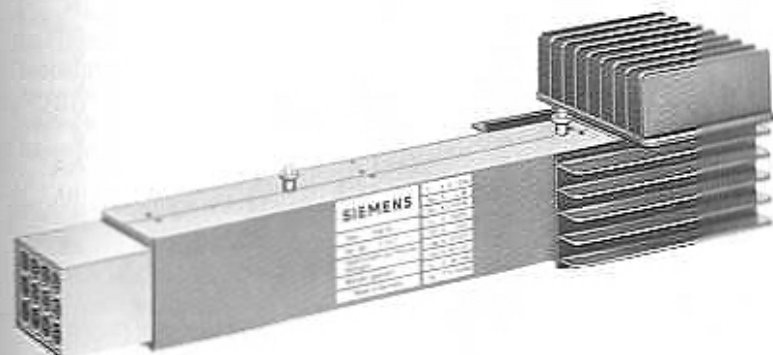

Traveling wave tube RW 85

Weight
Dimensions of tube

Dimensions of packing
RF connector
Mounting position

Ordering code Q41-X3285

approx. 3.3 kg net, approx. 3.6 kg gross
approx. 50 mm x 50 mm x 381 mm
(without radiators)
approx. 140 mm x 160 mm x 450 mm
Siemens coaxial connector 1,4/4,4 (50 Ω)
vertical

Heating

Heater voltage	U_h	6.3 ± 0.2	V ¹⁾
Heater current	I_h	≈ 0.57	A
Preheating time	t_c	none	

Indirectly heated by ac – also rectangular voltage up to 20 kHz or dc (+ pole to cathode)
metal capillary dispenser cathode

Characteristics ($f = 6.425 \dots 7.125$ GHz)

		min	nom	max	
Power gain ($P_2 = 22$ W)	V_c		39		dB
VSWR	S			2.1	²⁾
Cold attenuation	α		80		dB

Operating characteristics

Frequency	f	6.425 ... 7.125	GHz
Output power	P_c	22	W
Input power	P_i	2.8	mW
Collector voltage	U_c	1500	V
Helix voltage	U_h	3250 ($\pm 0.5\%$)	V
Grid 2 voltage	U_{G2}	2300 ... 2900	V ²⁾ ³⁾
Grid 1 voltage, negative	$-U_{G1}$	20	V
Helix current	I_h	≈ 1.2	mA
Grid 2 current	I_{G2}	$\leq \pm 0.1$	mA
Cathode current	I_c	51 ... 63	mA ³⁾
Noise figure	NF	≈ 24	dB
AM/PM conversion	K_a	≈ 3	%/dB ⁴⁾

¹⁾ If the maximum variation of the heater voltage exceeds the absolute limits of ± 0.2 V, the operating performance of the tube¹⁾ will be impaired and its life shortened.

²⁾ The tolerances quoted should be considered when designing the power supply.

³⁾ It is adjusted at a power input of 2.8 mW for a power output of 22 W.

⁴⁾ AM/PM conversion is the phase shift of the RF output signal when changing the input power by 1 dB.

⁵⁾ Hot match at tube's input and output throughout the frequency band 6.425 to 7.125 GHz.

Maximum ratings (absolute values)

Cold collector voltage	U_{C0}	max	2500	V
Collector voltage	U_c	min	1450	V
Collector voltage	U_c	max	1700	V
Collector dissipation	P_c	max	110	W
Cold helix voltage	U_{H0}	max	3800	V
Helix voltage	U_h	max	3500	V
Helix current	I_h	max	4	mA ¹⁾
Helix pulse load		max	45	Ws
Grid 2 voltage	U_{G2}	max	3200	V
Grid 2 current	I_{G2}	max	± 0.4	mA
Grid 2 pulse load		max	45	Ws
Grid 1 voltage, negative	$-U_{G1}$	min	10	V
Grid 1 voltage, negative	$-U_{G1}$	max	100	V
Cathode current	I_c	max	67	mA
Load reflection	P_{r1}	max	4	W
Conduction cooler temperature	t	max	120	°C ²⁾
Ambient temperature	t_{amb}	min	-30	°C
Ambient temperature	t_{amb}	max	65	°C
Storage temperature	t_{stg}	min	-40	°C
Storage temperature	t_{stg}	max	70	°C

Wiring of the high-voltage plug

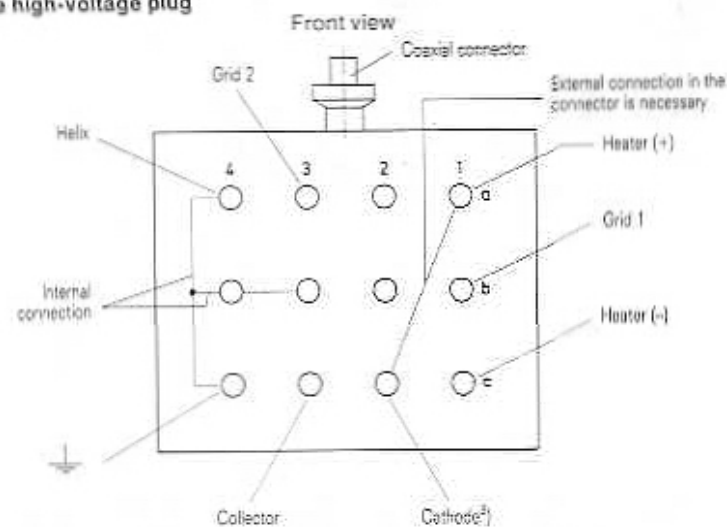

A female connector is available, type number RWZ 9635 (ordering code C61-X9526).

¹⁾ Trip level for helix overcurrent protection circuit.

²⁾ Measured at the temperature reference point (see outline drawing).

³⁾ The heater supply lead 1a must be connected in the connector with the cathode supply lead 2c. $R_{1a} \leq 1$ k Ω is permissible.

Outline drawing RW 85

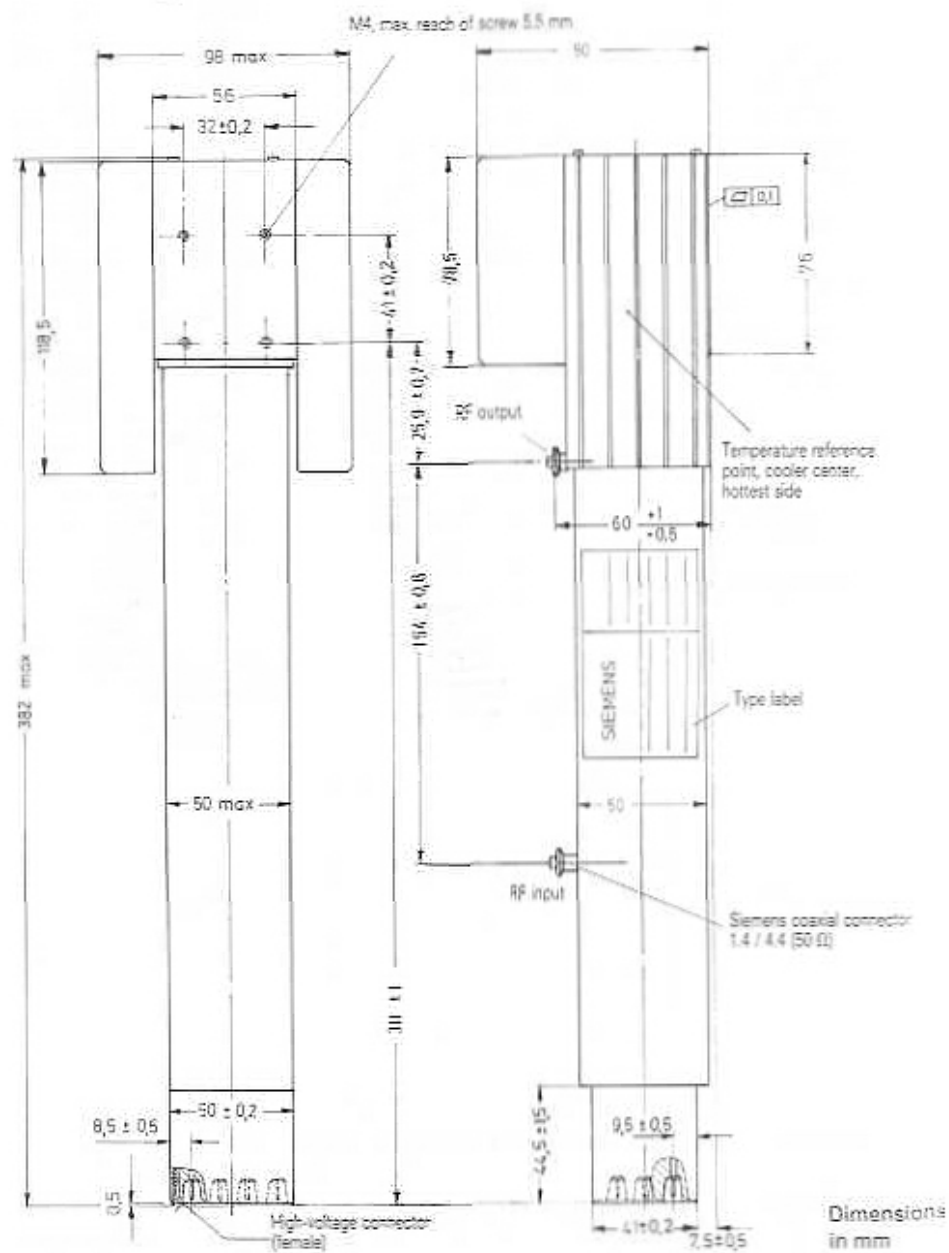

For replacement only

Power TWT preferably for analog radio link systems in the frequency band 5.9 to 6.425 GHz. RW 88 C supplies an output power of 11 W at a gain of 39 dB.

The use of a two-stage collector enables high efficiency to be achieved. Heat dissipation is independent of the RF input power, consequently the temperature will not increase if the RF input power falls. The PPM structure consists of alnico magnet rings. The RF power is coupled in and out by way of coaxial connectors.

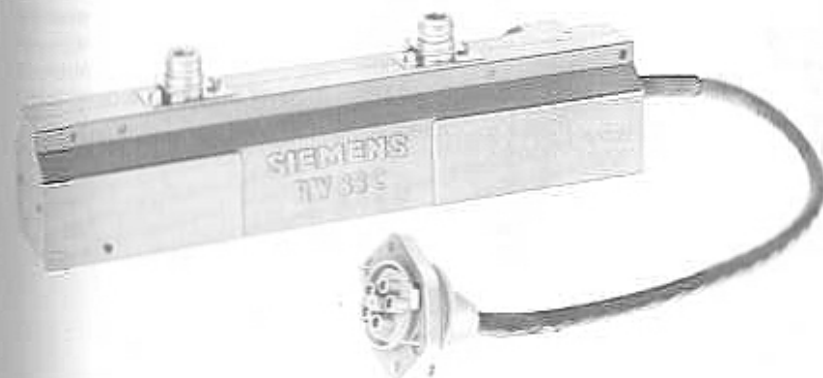

Traveling wave tube RW 88 C

Weight
Dimensions of tube
Dimensions of packing
RF connector
Mounting position

Ordering code Q41-X3296

approx. 1.6 kg net, approx. 3.1 kg gross
approx. 46 mm × 54 mm × 262 mm
approx. 205 mm × 145 mm × 455 mm
N connector (female)
any

Heating

Heater voltage	U_h	6.3 ± 0.2	V ¹⁾
Heater current	I_h	≈ 0.55	A
Preheating time	t_p	none	

Indirectly heated by dc (+ pole to cathode)
metal capillary dispenser cathode.

Characteristics ($f = 5.9$ to 6.425 GHz, $P_2 = 11$ W)

		min	nom	max	
Power gain	V_o		39		dB
Power gain slope (load VSWR ≤ 1.2)	$\Delta V_o / \Delta f$		0.008		dB/MHz
Cold VSWR	s			1.8	²⁾
Cold attenuation	a	80			dB

Operating characteristics

Frequency range	f	5.9 ... 6.425	GHz
Output power	P_2	11	W
Input power	P_1	1.4 (± 1 dB)	mW
Collector 1 voltage	U_{C1}	1350	V
Collector 2 voltage	U_{C2}	650	V
Helix voltage	U_H	2375	V
Grid 2 voltage	U_{G2}	1200 ... 1800	V
Cathode current	I_k	≤ 37	mA
Helix current	I_h	≈ 0.8	mA
Grid 2 current	I_{G2}	$\leq \pm 0.1$	mA
Noise figure	NF	≈ 24	dB
AM/PM conversion	k_p	≈ 4	%/dB ³⁾

¹⁾ If the maximum variation of the heater voltage exceeds the absolute limits of ± 0.2 V, the operating performance of the tube will be impaired and its life shortened.

²⁾ At input and output of cold tube in the frequency band 5.9 to 6.425 GHz.

³⁾ AM/PM conversion is the phase shift of the RF output signal when changing the input power by 1 dB.

Maximum ratings (absolute values)

Cold collector 1 voltage	U_{C1-0}	max	2500	V
Collector 1 voltage	U_{C1}	max	1500	V ¹⁾
Collector 1 dissipation	P_{C1}	max	30	W
Cold collector 2 voltage	U_{C2-0}	max	1200	V
Collector 2 voltage	U_{C2}	max	800	V ²⁾
Collector 2 dissipation	P_{C2}	max	30	W
Cold helix voltage	U_{H-0}	max	3200	V
Helix voltage	U_H	max	3000	V
Helix current	I_H	max	4	mA ³⁾
Grid 2 voltage	U_{G2}	max	3000	V
Grid 2 current	I_{G2}	max	± 0.3	mA
Cathode current	I_k	max	40	mA
Load reflection	P_{ref}	max	2.5	W
Case temperature	t_{case}	max	100	°C ⁴⁾
Ambient temperature	t_{amb}	min	-30	°C
Ambient temperature	t_{amb}	max	65	°C
Storage temperature	t_{sto}	min	-40	°C
Storage temperature	t_{sto}	max	75	°C
Storage life		max	5	years ⁵⁾
Height above mean sea level		max	3000	m

For operating instructions and detailed data refer to performance specifications.

¹⁾ The collector 1 voltage may not fall below the operating value by more than 50 V (including setting accuracy and voltage stability).

²⁾ The collector 2 voltage may not fall below the operating value by more than 30 V (including setting accuracy and voltage stability).

³⁾ Trip level for helix overcurrent protection circuit.

⁴⁾ Measured at the temperature reference point (see outline drawing).

⁵⁾ Refer to the warranty conditions.

Outline drawing RW 88 C

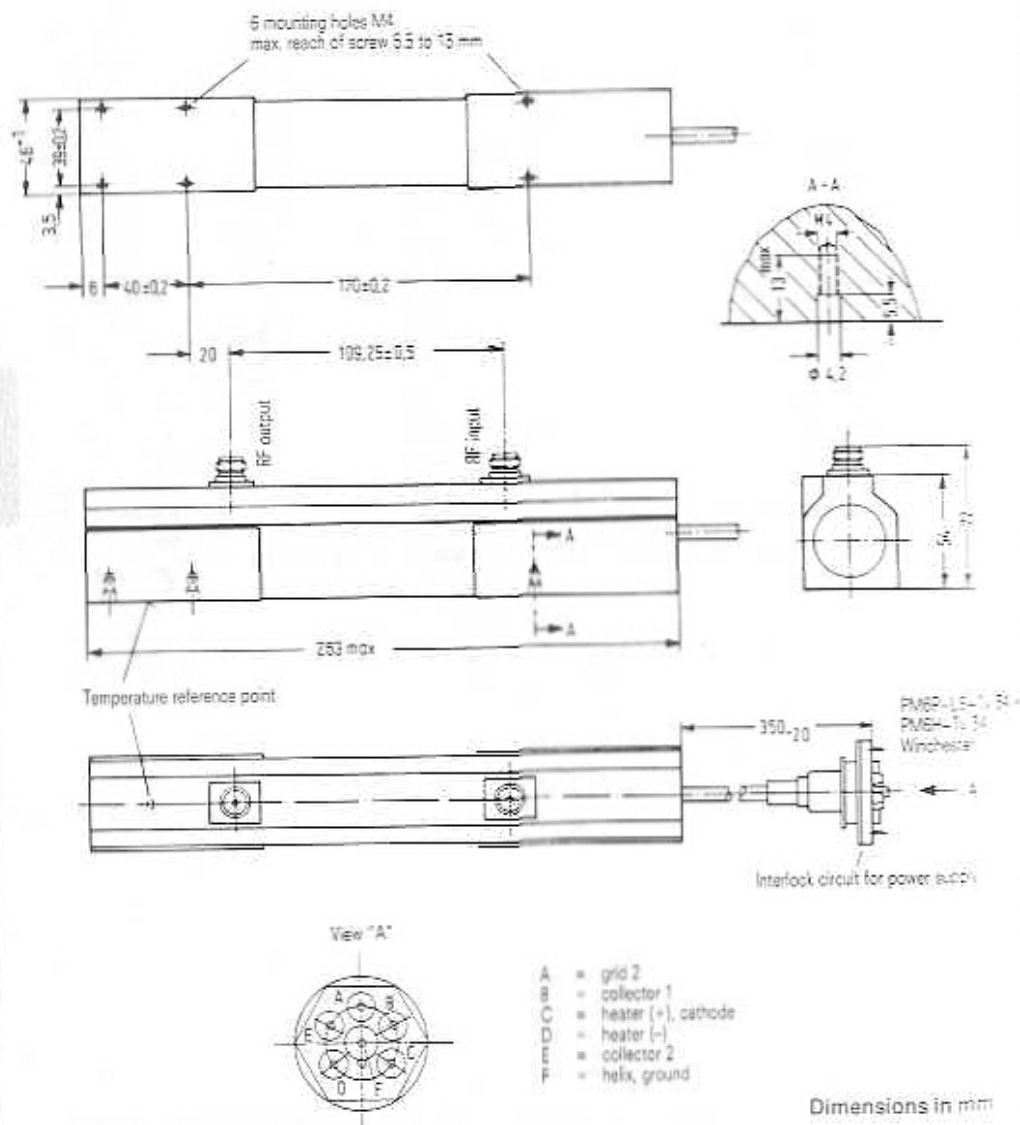

Dimensions in mm

Power TWT preferably for analog and 8 PSK digital radio link systems in the frequency band 5.9 to 7.1 GHz.

The tube supplies an output power of 15 W at a gain of 40 dB.

The use of a two-stage collector enables high efficiency to be achieved. Heat dissipation is independent of the RF input power, consequently the temperature will not increase if the RF input power falls. The PPM structure consists of samarium cobalt magnet rings. The RF power is coupled in and out by way of coaxial connectors.

RW 89 and RW 89 D only differ in their high voltage connectors.

Power supply RWN 110 is available for operation of version RW 89 and RWN 120 or RWN 121 with control unit BT 300 for version RW 89 D. The rated input voltage ranges from 24 to 60 V without switching.



Traveling wave tube RW 89
Traveling wave tube RW 89 D

Weight
Dimensions of tube
Dimensions of packing
RF connector
Mounting position

Ordering code Q41-X3297
Ordering code Q41-X3283

approx. 2.0 kg net, approx. 3.3 kg gross
approx. 49 mm × 54 mm × 290 mm
approx. 210 mm × 155 mm × 460 mm
N connector (female)
any

Heating

Heater voltage	U_h	6.3 ± 0.2	V ¹⁾
Heater current	I_h	≈ 0.55	A
Preheating time	t_h	≥ 60	s

indirectly heated by dc (+pole to cathode)
metal capillary dispenser cathode

Characteristics ($f = 5.9 \dots 7.125$ GHz, $P_2 = 15$ W)

		min	nom	max	
Power gain	V_o		40		dB
Power gain slope (load VSWR ≤ 1.2)	$\Delta V_o / \Delta f$		0.005		dB/MHz
Cold VSWR	s			1.8	²⁾
Cold attenuation	a	80			dB

Operating characteristics

		Analog	Digital 8 PSK	
Application				
Frequency range	f	5.9 ... 7.125	5.9 ... 7.125	GHz
Output power	P_2	15	3	W
Power gain	V_o	40 ± 1	≈ 47	dB
Collector 1 voltage	U_{C1}	1150	1150	V
Collector 2 voltage	U_{C2}	550	550	V
Helix voltage				
(5.9 ... 6.425 GHz)	U_h	2500	2500	V
(6.4 ... 7.125 GHz)	U_h	2500	2500	V
Grid 2 voltage	U_{G2}	1250 ... 2000	1300 ... 2100	V
Cathode current	I_k	≤ 55	55 ± 2	mA
Helix current	I_H	≈ 1	≈ 1	mA
Grid 2 current	I_{G2}	$\leq \pm 0.1$	$\leq \pm 0.1$	mA
Noise figure	NF	≈ 22	≈ 22	dB
AM/PM conversion	K_p	≈ 2.5	≈ 1.2	³⁾ dB ²⁾
3rd order intercept point	IP_3	≥ 45.5	≥ 46	dBm

¹⁾ If the maximum variation of the heater voltage exceeds the absolute limits of ± 0.2 V, the operating performance of the tube will be impaired and its life shortened.

²⁾ At input and output of cold tube in the frequency band 5.9 to 7.125 GHz.

³⁾ AM/PM conversion is the phase shift of the RF output signal when changing the input power by 1 dB.

Maximum ratings (absolute values)

Cold collector 1 voltage	U_{C10}	max	2500	V
Collector 1 voltage	U_{C1}	max	1400	V ¹⁾
Collector 1 dissipation	P_{C1}	max	40	W
Cold collector 2 voltage	U_{C20}	max	1200	V
Collector 2 voltage	U_{C2}	max	800	V ²⁾
Collector 2 dissipation	P_{C2}	max	40	W
Cold helix voltage	U_{H0}	max	3200	V
Helix voltage	U_H	max	3000	V
Helix current	I_H	max	4	mA ³⁾
Grid 2 voltage	U_{G2}	max	3000	V
Grid 2 current	I_{G2}	max	± 0.3	mA
Cathode current	I_k	max	60	mA
Load reflection	P_{r1}	max	2.5	W
Case temperature	t_{case}	max	100	°C ⁴⁾
Ambient temperature	t_{amb}	min	-30	°C
Ambient temperature	t_{amb}	max	65	°C
Storage temperature	t_{sto}	min	-40	°C
Storage temperature	t_{sto}	max	75	°C
Storage life		max	5	years ⁵⁾
Height above mean sea level		max	4500	m

For operating instructions and detailed data refer to performance specifications.

¹⁾ The collector 1 voltage may not fall below the operating value by more than 50 V (including setting accuracy and voltage stability).

²⁾ The collector 2 voltage may not fall below the operating value by more than 30 V (including setting accuracy and voltage stability).

³⁾ Trip level for helix overcurrent protection circuit.

⁴⁾ Measured at the temperature reference point (see outline drawing).

⁵⁾ Refer to warranty conditions.

Outline drawing RW 89/89 D

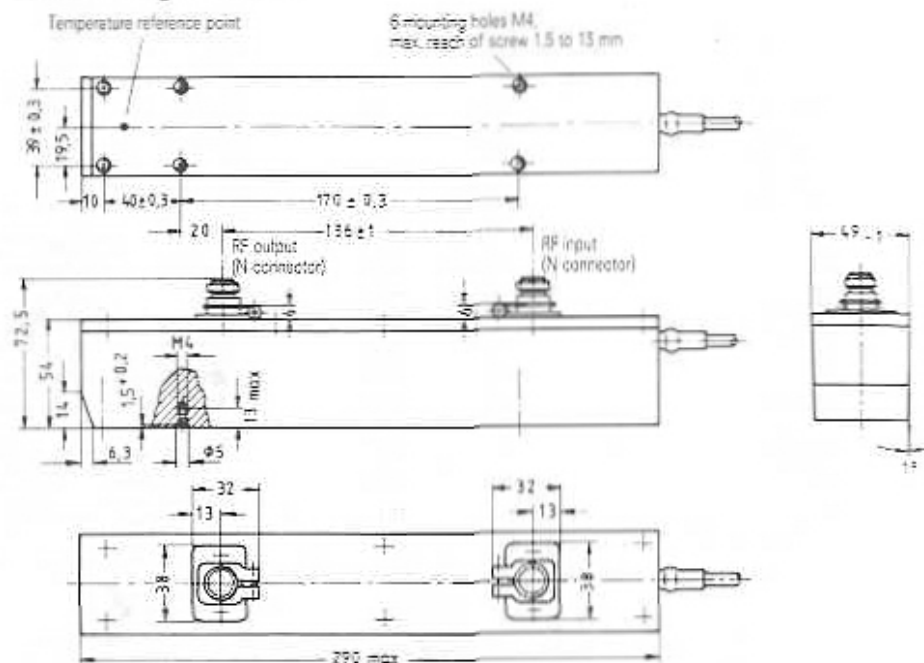

RW 89
Connector
PM6P-LS-Ty 34 +
PM6H-Ty 34

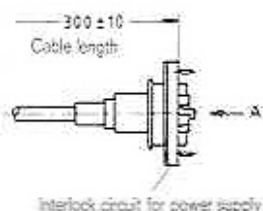

View "A"

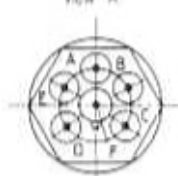

- A = grid 2
- B = collector 1
- C = heater (+), cathode
- D = heater (-)
- E = collector 2
- F = helix, ground

RW 89D
Connector
MRAC 66 PJ

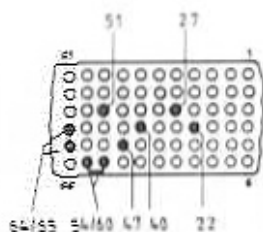
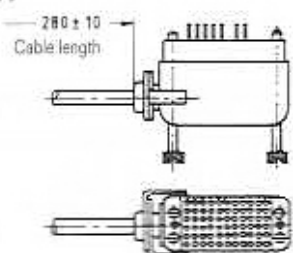

- 22 = heater (-)
- 27 = heater (+), cathode
- 47 = grid 2
- 51 = collector 1
- 40 = collector 2
- 64/65 = helix, ground
- 54/60 = interlock circuit

Dimensions in mm

Power TWT preferably for analog and 8 PSK digital radio link systems in the frequency band 7.1 to 8.5 GHz.

The tube supplies an output power of 15 W at a gain of 40 dB.

The use of a two-stage collector enables high efficiency to be achieved. Heat dissipation is independent of the RF input power, consequently the temperature will not increase if the RF input power falls. The PPM structure consists of samarium cobalt magnet rings. The RF power is coupled in and out by way of coaxial connectors.

RW 90 and RW 90 D only differ in their high voltage connectors.

Power supply RWN 110 is available for operation of version RW 90 and RWN 120 or RWN 121 with control unit BT 300 for version RW 90 D. The rated input voltage ranges from 24 to 60 V without switching.

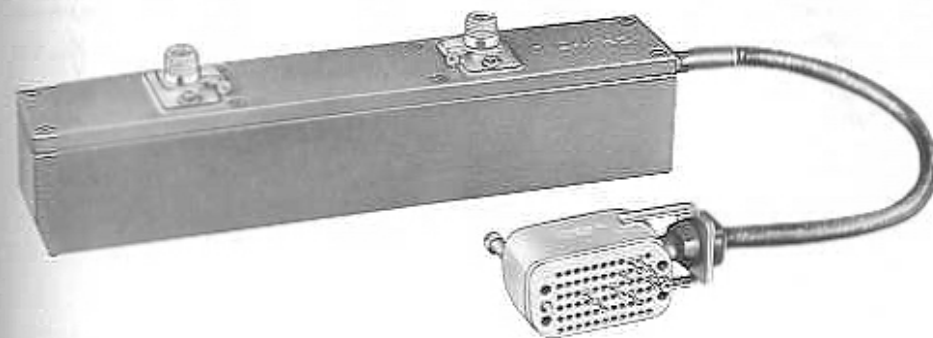

Traveling wave tube RW 90
Traveling wave tube RW 90 D

Weight
Dimensions of tube
Dimensions of packing
RF connector
Mounting position

Ordering code Q41-X3299
Ordering code Q41-X3275

approx. 2.0 kg net, approx. 3.3 kg gross
approx. 49 mm × 54 mm × 290 mm
approx. 210 mm × 155 mm × 460 mm
N connector (female)
any

Heating

Heater voltage	U_h	6.3 ± 0.2	V ¹⁾
Heater current	I_h	≈ 0.55	A
Preheating time	t_p	≥ 60	s

indirectly heated by dc (+pole to cathode)
metal capillary dispenser cathode

Characteristics ($f = 7.1 \dots 8.5$ GHz, $P_2 = 15$ W)	min	nom	max	
Power gain	V_2	40		dB
Power gain slope (load VSWR ≤ 1.2)	$\Delta V_2 / \Delta f$	0.005		dB/MHz
Cold VSWR	s		1.8	$\frac{1}{s}$
Cold attenuation	α	80		dB

Operating characteristics

Application		Analog	Digital 8 PSK	
Frequency range	f	7.1 ... 8.5	7.1 ... 8.5	GHz
Output power	P_{2c}	15	3	W
Power gain	V_2	40 ± 1	≈ 46	dB
Collector 1 voltage	U_{C1}	1150	1150	V
Collector 2 voltage	U_{C2}	550	550	V
Helix voltage	U_H	2550	2550	V
Grid 2 voltage	U_{G2}	1300 ... 2000	1300 ... 2100	V
Cathode current	I_K	≤ 55	53 ± 2	mA
Helix current	I_H	≈ 1	≈ 1	mA
Grid 2 current	I_{G2}	$\leq \pm 0.1$	$\leq \pm 0.1$	mA
Noise figure	NF	≈ 25	≈ 25	dB
AM/PM conversion	k_p	≈ 3	≈ 1.5	$\frac{1}{\text{dB}^2}$
3rd order intercept point	IP_3	≥ 45.5	≥ 46	dBm

¹⁾ If the maximum variation of the heater voltage exceeds the absolute limits of ± 0.2 V, the operating performance of the tube will be impaired and its life shortened.

²⁾ At input and output of the cold tube in the frequency range 7.1 to 8.5 GHz.

³⁾ AM/PM conversion is the phase shift of the RF output signal when changing the input power by 1 dB.

Maximum ratings (absolute values)

Cold collector 1 voltage	U_{C10}	max	2500	V
Collector 1 voltage	U_{C1}	max	1400	V ¹⁾
Collector 1 dissipation	P_{C1}	max	40	W
Cold collector 2 voltage	U_{C20}	max	1200	V
Collector 2 voltage	U_{C2}	max	800	V ²⁾
Collector 2 dissipation	P_{C2}	max	40	W
Cold helix voltage	U_{H0}	max	3200	V
Helix voltage	U_H	max	3000	V
Helix current	I_H	max	4	mA ³⁾
Grid 2 voltage	U_{G2}	max	3000	V
Grid 2 current	I_{G2}	max	± 0.3	mA
Cathode current	I_K	max	60	mA
Load reflection	P_{rl}	max	2.5	W
Case temperature	t_{case}	max	100	$^{\circ}\text{C}^{4)}$
Ambient temperature	t_{amb}	min	-30	$^{\circ}\text{C}$
Ambient temperature	t_{amb}	max	65	$^{\circ}\text{C}$
Storage temperature	t_{stg}	min	-40	$^{\circ}\text{C}$
Storage temperature	t_{stg}	max	75	$^{\circ}\text{C}$
Storage life		max	5	years ⁵⁾
Height above mean sea level		max	4500	m

For operating instructions and detailed data refer to performance specifications.

¹⁾ The collector 1 voltage may not fall below the operating value by more than 50 V (including setting accuracy and voltage stability).

²⁾ The collector 2 voltage may not fall below the operating value by more than 30 V (including setting accuracy and voltage stability).

³⁾ The level for helix overcurrent protection circuit.

⁴⁾ Measured at the temperature reference point (see outline drawing).

⁵⁾ Refer to warranty conditions.

Outline drawing RW 90/90 D

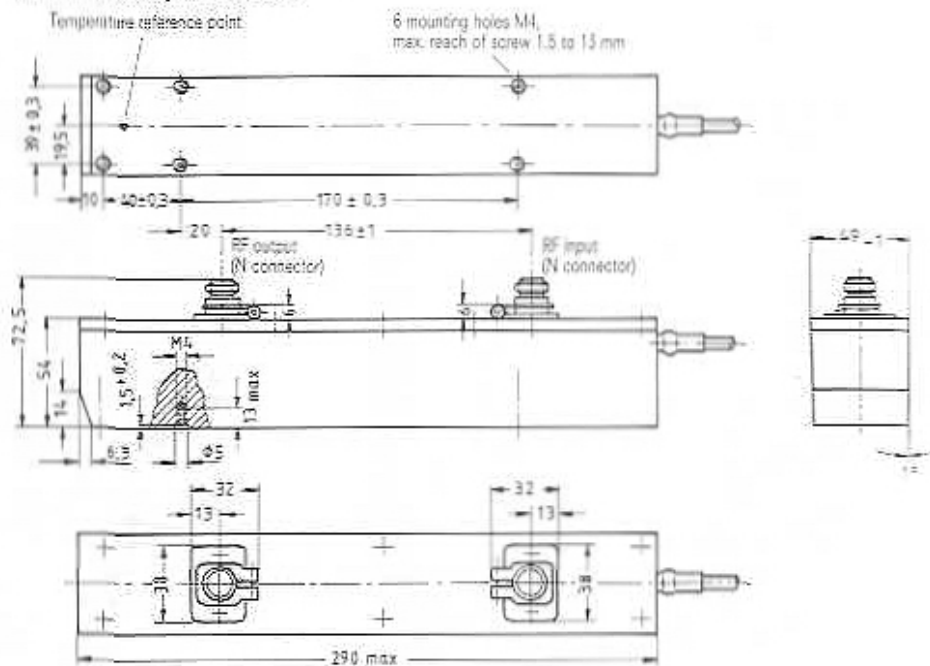

RW 90
Connector
PM6P-LS-Ty 34
PM6R-Ty 34

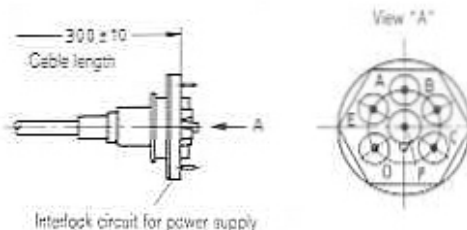

- 4 = grid 2
- 5 = collector 1
- 6 = heater (+), cathode
- 7 = heater (-)
- 8 = collector 2
- 9 = Heib, ground

RW 90D
Connector
MRAC 66 P1

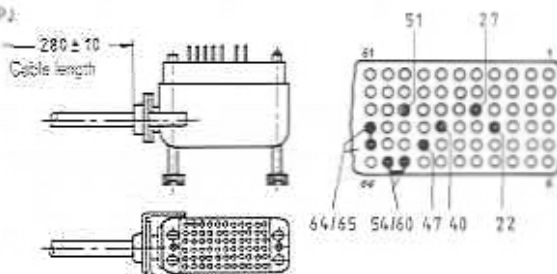

- 22 = heater (-)
- 27 = heater (+), cathode
- 47 = grid 2
- 51 = collector 1
- 49 = collector 2
- 64/65 = Heib, ground
- 56/60 = interlock circuit

Dimensions in mm

Highly linear power TWT preferably for SSB and 16-QAM digital radio link systems in the frequency band 5.9 to 7.125 GHz.

The tube supplies a continuous output power of up to 8 W and a peak output power of up to 15 W; the average power gain amounts to 45 dB. The 3rd order intercept point is at least 49 dBm. Within the ambient temperature range the output power is kept constant by means of compensation.

The use of a two-stage collector improves efficiency. The PPM structure consists of samarium cobalt magnet rings. The RF power is coupled in and out by way of coaxial connectors.

Dissipation heat is removed by conduction.

Power supplies RWN 220 or RWN 221 with control unit BT 300 are available for tube operation. The rated input voltage ranges from 24 to 60 V without switching.



Traveling wave tube RW 189

- Weight
- Dimensions of tube
- Dimensions of packing
- RF connector
- Mounting position

Ordering code Q41-X3302

- approx. 2.0 kg net, approx. 3.3 kg gross
- approx. 49 mm x 54 mm x 290 mm
- approx. 210 mm x 155 mm x 460 mm
- N connector (female)
- any

Heating

Heater voltage	U_f	6.3 ± 0.2	V ¹⁾
Heater current	I_f	≈ 0.55	A
Preheating time indirectly heated by dc (+pole to cathode) metal capillary dispenser cathode	t_h	≈ 60	s

Characteristics ($f = 5.9 \dots 6.425$ GHz, $P_2 = 30$ dBm)	min	nom	max		
Power gain	V_p	43	45	47	dB
Power gain slope (load VSWR ≤ 1.2)	$\Delta V_p / \Delta f$		0.005		dB/MHz
3rd order intercept point	IP_3	49			dBm
Cold VSWR	s		1.8		τ
Cold attenuation	a	80			dB

Operating characteristics

Application		SSB	Digital 16 QAM	
Frequency range	f	5.9 ... 6.425	5.9 ... 7.125	GHz
Output power	P_2	30	35	dBm
Power gain	V_p	≈ 45	≈ 42.5	dB
Collector 1 voltage	U_{C1}	1450	1450	V
Collector 2 voltage	U_{C2}	400	400	V
Helix voltage	U_H	2700	2650	V
Grid 2 voltage	U_{G2}	1800 ... 2400	1750 ... 2300	V
Cathode current	I_K	≈ 100	≈ 90	mA
Helix current	I_H	≈ 0.5	≈ 0.5	mA
Grid 2 current	I_{G2}	$\leq \pm 0.2$	$\leq \pm 0.2$	mA
Noise figure	NF	≈ 21	≈ 21	dB
AM/PM conversion	k_p	≈ 0.3	≈ 0.6	%/dB ²⁾
Intermodulation product ($P_{SCL} = 27$ dBm)	d_{S2}	≈ 44		dB
($P_{SCL} = 32$ dBm)	d_{S2}		≈ 32	dB

¹⁾ If the maximum variation of the heater voltage exceeds the absolute limits of ± 0.2 V, the operating performance of the tube will be impaired and its life shortened.

²⁾ At input and output of the cold tube in the frequency band 5.9 to 7.125 GHz.

³⁾ AM/PM conversion is the phase shift of the RF output signal when changing the input power by 1 dB.

Maximum ratings (absolute values)

Cold collector 1 voltage	U_{C1D}	max	2700	V
Collector 1 voltage	U_{C1}	min	1400	V
Collector 1 voltage	U_{C1}	max	1800	V
Collector 1 dissipation	P_{C1}	max	45	W
Cold collector 2 voltage	U_{C2D}	max	1500	V
Collector 2 voltage	U_{C2}	min	370	V
Collector 2 voltage	U_{C2}	max	900	V
Collector 2 dissipation	P_{C2}	max	70	W
Cold helix voltage	U_{HD}	max	3200	V
Helix voltage	U_H	max	3000	V
Helix current	I_H	max	4	mA ¹⁾
Grid 2 voltage	U_{G2}	max	3000	V
Grid 2 current	I_{G2}	max	-0.2/+0.5	mA
Cathode current	I_K	max	110	mA
Load reflection	P_{R1}	max	2.5	W
Output power	P_2	max	8	W ²⁾
Pulse output power ($t_{on} \leq 50$ ms, $D \leq 30\%$)	P_{2D}	max	15	W
Case temperature	t_{case}	max	90	°C ³⁾
Ambient temperature	t_{amb}	min	-20	°C
Ambient temperature	t_{amb}	max	65	°C
Storage temperature	t_{stg}	min	-40	°C
Storage temperature	t_{stg}	max	75	°C
Storage life		max	5	years ⁴⁾
Height above mean sea level		max	4500	m

For operating instructions and detailed data refer to performance specifications.

¹⁾ Trip level for helix overcurrent protection circuit.

²⁾ With setting for 30 dBm operation max. 5 W.

³⁾ Measured at the temperature reference point (see outline drawing).

⁴⁾ Refer to warranty conditions.

Outline drawing RW 189

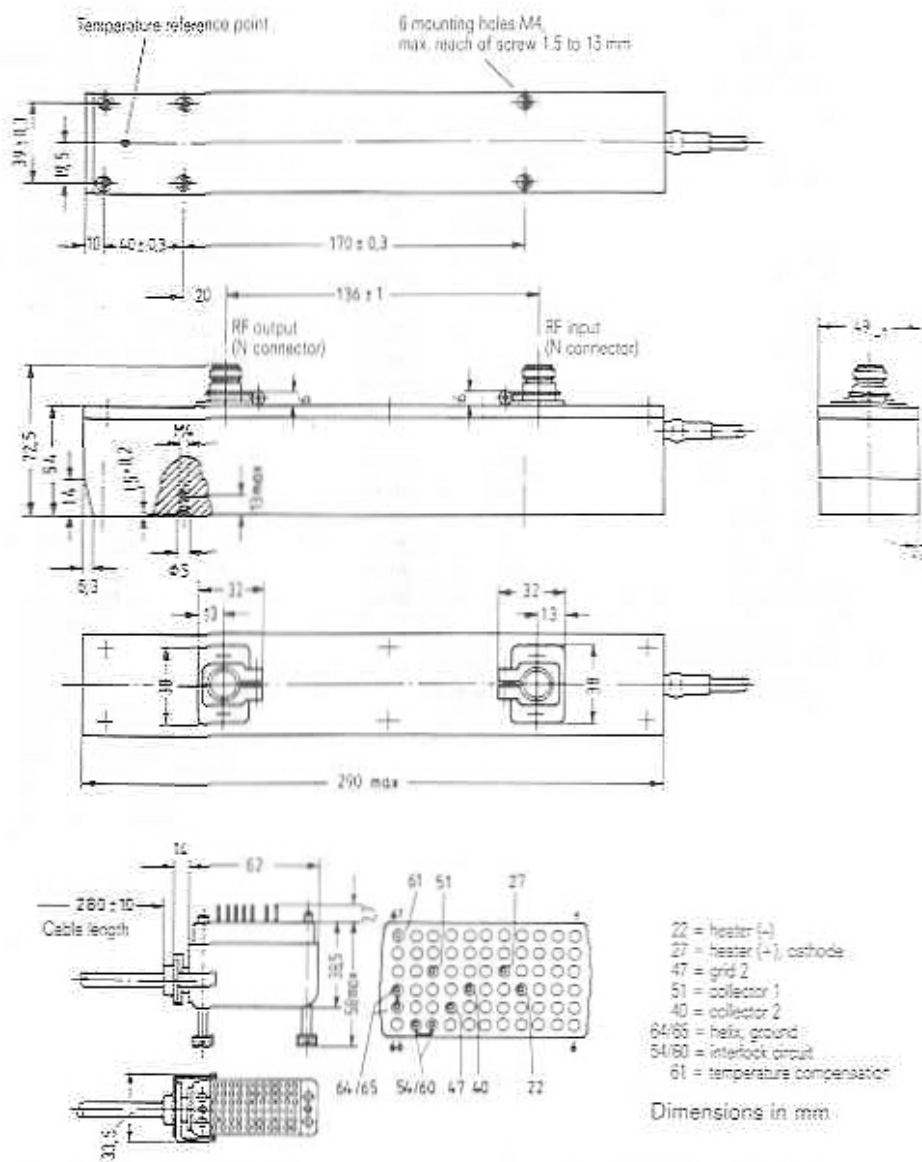

Highly linear power TWT preferably for 64 QAM digital radio link systems in the frequency band 3.6 to 4.2 GHz. RW 248 can also be used for analog operation.

The tube supplies a continuous output power of up to 10 W and a peak output power of up to 30 W; the average power gain amounts to 46 dB. The 3rd order intercept point is at least 51 dBm. Within the ambient temperature range the output power is kept constant by means of compensation.

The use of a two-stage collector improves efficiency. The PPM structure consists of alnico magnet rings. The RF power is coupled in and out by way of coaxial connectors.

Dissipation heat is removed by conduction.

Power supplies RWN 320 or RWN 321 with control unit BT 300 are available for tube operation. The rated input voltage ranges from 24 to 60 V without switching.

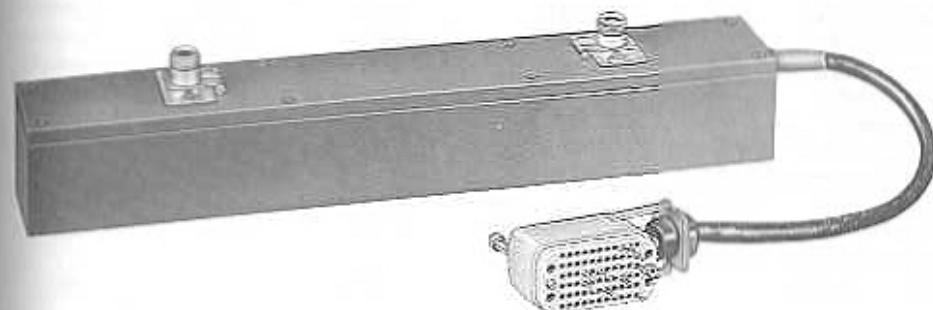

Traveling wave tube RW 248

- Weight
- Dimensions of tube
- Dimensions of packing
- RF connector
- Mounting position

Ordering code Q41-X3311

- approx. 2.6 kg net, approx. 4.4 kg gross
- approx. 55 mm × 54 mm × 380 mm
- approx. 210 mm × 155 mm × 560 mm
- N connector (female)
- any

Heating

Heater voltage	U_F	6.3 ± 0.2	V ¹⁾
Heater current	I_F	≈ 0.55	A
Preheating time	t_h	≥ 60	s

indirectly heated by dc (+pole to cathode)
metal capillary dispenser cathode

Characteristics ($f = 3.6 \dots 4.2$ GHz, $P_2 = 36$ dBm)	min	nom	max		
Power gain	V_o	45	46	47	dB
Power gain slope (load VSWR ≤ 1.2)	$\Delta V_o / \Delta f$		0.005		dB/MHz
3rd order intercept point	IP_3	51			dBm
Cold VSWR	s			1.8	²⁾
Cold attenuation	α	80			dB

Operating characteristics

Application		Digital	Analog	
Frequency range	f	3.6 ... 4.2	3.6 ... 4.2	GHz
Output power	P_2	36	40	dBm
Power gain	V_o	≈ 46	40	dB
Collector 1 voltage	U_{C1}	2000	2000	V
Collector 2 voltage	U_{C2}	330	330	V
Helix voltage	U_H	3700	3600	V
Grid 2 voltage	U_{G2}	2700 ... 3400	2100 ... 3000	V
Cathode current	I_k	≈ 120	≈ 90	mA
Helix current	I_H	≈ 0.5	≈ 0.8	mA
Grid 2 current	I_{G2}	$\leq \pm 0.2$	$\leq \pm 0.2$	mA
Noise figure	NF	≈ 21	≈ 21	dB
AM/PM conversion	k_a	≈ 0.4	≈ 1.5	³⁾ dB ²⁾
Intermodulation product ($P_{SCL} = 33$ dBm)	$d_{3,2}$	≈ 38		dB

¹⁾ If the maximum variation of the heater voltage exceeds the absolute limits of ± 0.2 V, the operating performance of the tube will be impaired and its life shortened.

²⁾ At input and output of the cold tube in the frequency range 3.6 to 4.2 GHz.

³⁾ AM/PM conversion is the phase shift of the RF output signal when changing the input power by 1 dB.

Maximum ratings (absolute values)

Cold collector 1 voltage	$U_{C1,0}$	max	3200	V
Collector 1 voltage	U_{C1}	min	1950	V
Collector 1 voltage	U_{C1}	max	2300	V
Collector 1 dissipation	P_{C1}	max	70	W
Cold collector 2 voltage	$U_{C2,0}$	max	1500	V
Collector 2 voltage	U_{C2}	min	300	V
Collector 2 voltage	U_{C2}	max	900	V
Collector 2 dissipation	P_{C2}	max	80	W
Cold helix voltage	$U_{H,0}$	max	4100	V
Helix voltage	U_H	max	3900	V
Helix current	I_H	max	3	mA ¹⁾
Grid 2 voltage	U_{G2}	max	3500	V
Grid 2 current	I_{G2}	max	-0.2/+0.5	mA
Cathode current	I_k	max	140	mA
Load reflection	P_{ref}	max	3	W
Output power	P_2	max	15	W
Pulse output power ($t_{max} \leq 50$ ms, $D \leq 30$ %)	$P_{2,p}$	max	30	W
Case temperature	t_{case}	max	90	²⁾ °C
Ambient temperature	t_{amb}	min	-20	°C
Ambient temperature	t_{amb}	max	70	°C
Storage temperature	t_{stg}	min	-40	°C
Storage temperature	t_{stg}	max	75	°C
Storage life		max	5	years ³⁾
Height above mean sea level		max	4500	m

For operating instructions and detailed data refer to performance specifications.

¹⁾ Trip level for helix overcurrent protection circuit.

²⁾ Measured at the temperature reference point (see outline drawing).

³⁾ Refer to warranty conditions.

Outline drawing RW 248

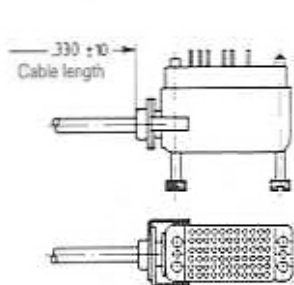
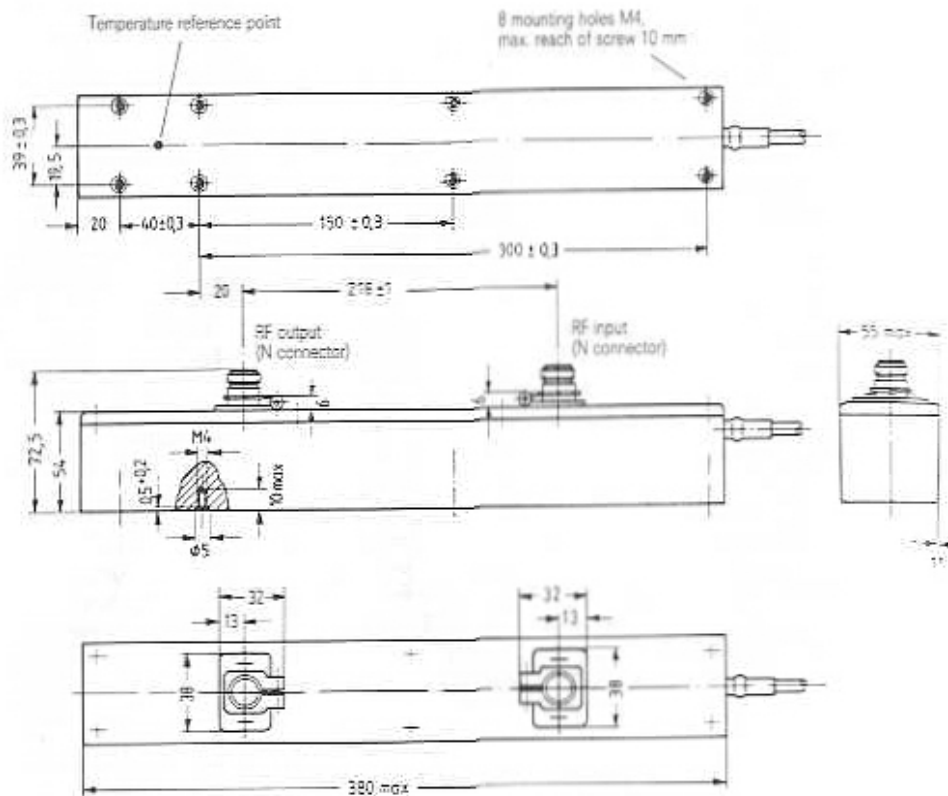

- 22 = heater (-)
- 21 = heater (+), cathode
- 38 = grid 2
- 51 = collector 1
- 34 = collector 2
- 64/65 = helix, ground
- 54/60 = interlock circuit
- 61 = temperature compensator

Dimensions in mm

Highly linear power TWT preferably for 64 QAM digital radio link systems in the frequency band 5.9 to 7.125 GHz.

The tube supplies a continuous output power of up to 10 W and a peak output power of up to 30 W; the average power gain amounts to 46 dB. The 3rd order intercept point is at least 51 dBm. Within the ambient temperature range the output power is kept constant by means of compensation.

The use of a two-stage collector improves efficiency. The PPM structure consists of samarium cobalt magnet rings. The RF power is coupled in and out by way of coaxial connectors.

Dissipation heat is removed by conduction.

Power supplies RWN 320 or RWN 321 with control unit BT 300 are available for tube operation. The rated input voltage ranges from 24 to 60 V without switching.

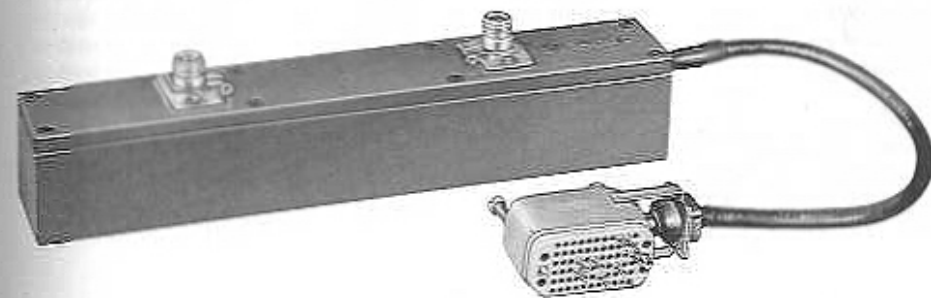

Traveling wave tube 289

- Weight
- Dimensions of tube
- Dimensions of packing
- RF connector
- Mounting position

Ordering code Q41-X3310

- approx. 2.2 kg net, approx. 4.0 kg gross
- approx. 49 mm × 54 mm × 320 mm
- approx. 210 mm × 155 mm × 560 mm
- N connector (female)
- any

Heating

Heater voltage	U_F	6.3 ± 0.2	V ¹⁾
Heater current	I_F	≈ 0.55	A
Preheating time	t_h	≥ 60	s

indirectly heated by dc (+pole to cathode)
metal capillary dispenser cathode

Characteristics ($f = 5.9 \dots 7.125$ GHz, $P_2 = 36$ dBm)	min	nom	max		
Power gain	V_c	45	46	47	dB
Power gain slope (load VSWR ≤ 1.2)	$\Delta V_c / \Delta f$		0.005		dB/MHz
3rd order intercept point	IP_3	51			dBm
Cold VSWR	s			1.8	²⁾
Cold attenuation	α	80			dB

Operating characteristics

Frequency range	f	5.9 ... 7.125	5.9 ... 6.425	GHz
Output power	P_2	36	38	dBm
Power gain	V_p	≈ 46	≈ 46	dB
Collector 1 voltage	U_{C1}	1800	2000	V
Collector 2 voltage	U_{C2}	300	330	V
Helix voltage	U_H	4000	4000	V
Grid 2 voltage	U_{G2}	2600 ... 3300	2600 ... 3300	V
Cathode current	I_K	≈ 110	≈ 110	mA
Helix current	I_H	≈ 0.5	≈ 0.5	mA
Grid 2 current	I_{G2}	$\leq \pm 0.2$	$\leq \pm 0.2$	mA
Noise figure	NF	≈ 21	≈ 21	dB
AM/PM conversion	k_p	≈ 0.4	≈ 0.6	³⁾ /dB ³⁾
Intermodulation product ($P_{SCL} = 33$ dBm)	d_{32}	≈ 38		dB
($P_{SCL} = 35$ dBm)	d_{33}		≈ 34	dB

¹⁾ If the maximum variation of the heater voltage exceeds the absolute limits of ± 0.2 V, the operating performance of the tube will be impaired and its life shortened.

²⁾ At input and output of the cold tube in the frequency band 5.9 to 7.125 GHz.

³⁾ AM/PM conversion is the phase shift of the RF output signal when changing the input power by 1 dB.

Maximum ratings (absolute values)

Cold collector 1 voltage	U_{C10}	max	3000	V
Collector 1 voltage	U_{C1}	min	1750	V
Collector 1 voltage	U_{C1}	max	2200	V
Collector 1 dissipation	P_{C1}	max	70	W
Cold collector 2 voltage	U_{C20}	max	1500	V
Collector 2 voltage	U_{C2}	min	270	V
Collector 2 voltage	U_{C2}	max	900	V
Collector 2 dissipation	P_{C2}	max	80	W
Cold helix voltage	U_{H0}	max	4500	V
Helix voltage	U_H	max	4300	V
Helix current	I_H	max	3	mA ¹⁾
Grid 2 voltage	U_{G2}	max	3500	V
Grid 2 current	I_{G2}	max	-0.2/+0.5	mA
Cathode current	I_K	max	130	mA
Load reflection	P_{rl}	max	3	W
Output power	P_2	max	10	W
Pulse output power ($t_{imp} \leq 50$ ms, $D \leq 30$ %)	P_{2p}	max	30	W
Case temperature	t_{case}	max	90	°C ²⁾
Ambient temperature	t_{amb}	min	-20	°C
Ambient temperature	t_{amb}	max	70	°C
Storage temperature	t_{stg}	min	-40	°C
Storage temperature	t_{stg}	max	75	°C
Storage life		max	5	years ³⁾
Height above mean sea level		max	4500	m

For operating instructions and detailed data refer to performance specifications.

¹⁾ Trip level for helix overcurrent protection circuit.

²⁾ Measured at the temperature reference point (see outline drawing).

³⁾ Refer to warranty conditions.

Outline drawing RW 289

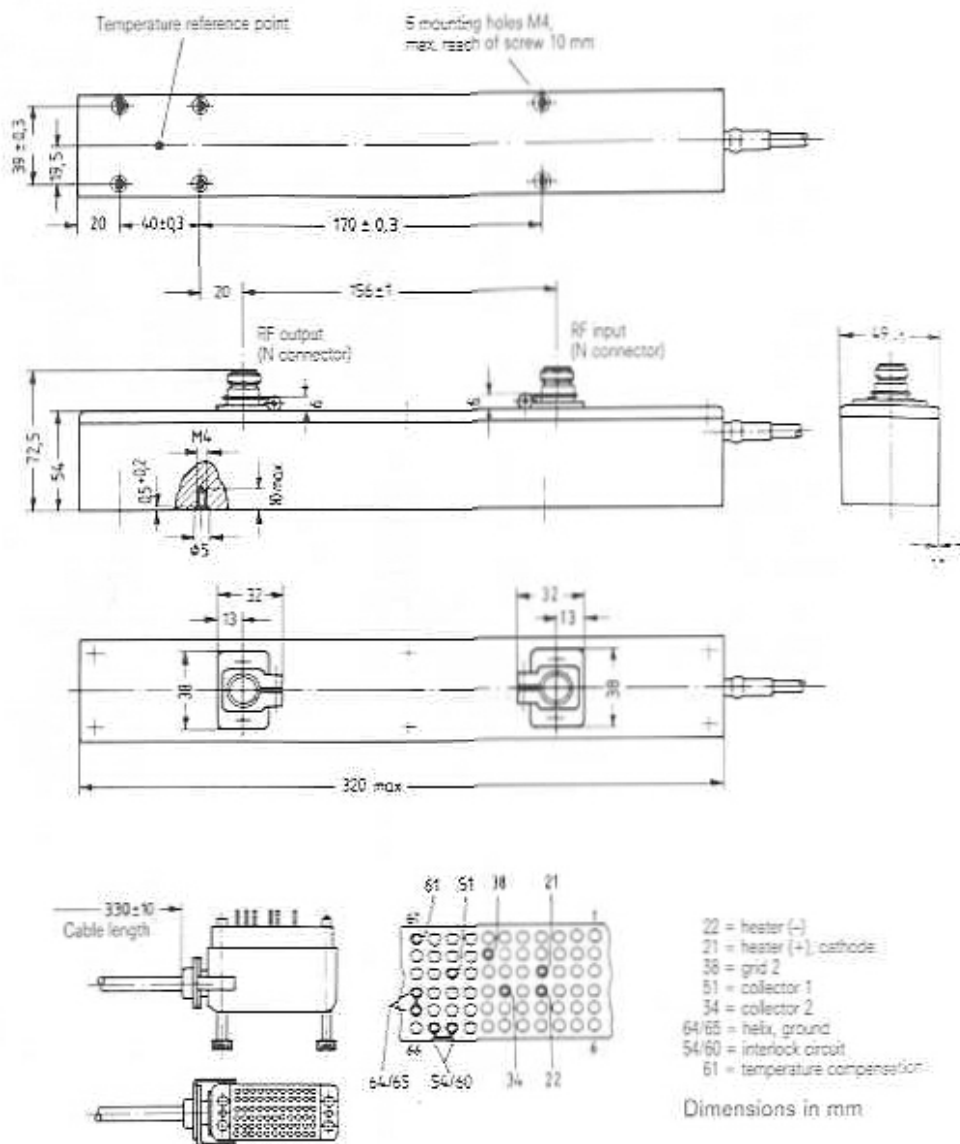

Highly linear power TWT preferably for 64 QAM digital radio link systems in the frequency band 7.1 to 8.5 GHz.

The tube supplies a continuous output power of up to 10 W and a peak output power of up to 30 W; the average power gain amounts to 46 dB. The 3rd order intercept point is at least 51 dBm. Within the ambient temperature range the output power is kept constant by means of compensation.

The use of a two-stage collector improves efficiency. The PPM structure consists of samarium cobalt magnet rings. The RF power is coupled in and out by way of coaxial connectors.

Dissipation heat is removed by conduction.

Power supplies RWN 320 or RWN 321 with control unit BT 300 are available for tube operation. The rated input voltage ranges from 24 to 60 V without switching.

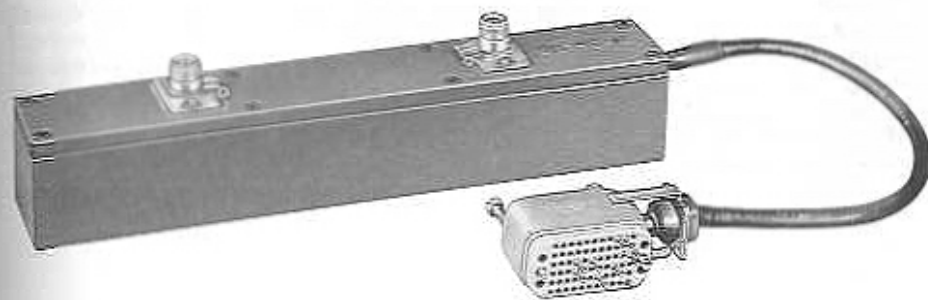

Traveling wave tube RW 290

- Weight
- Dimensions of tube
- Dimensions of packing
- RF connector
- Mounting position

Ordering code Q41-X3315

- approx. 2.2 kg net, approx. 4.0 kg gross
- approx. 49 mm × 54 mm × 320 mm
- approx. 210 mm × 155 mm × 560 mm
- N connector (female)
- any

Heating

Heater voltage	U_h	6.3 ± 0.2	V ¹⁾
Heater current	I_h	≈ 0.55	A
Preheating time	t_h	≥ 60	s

indirectly heated by dc (+pole to cathode)
metal capillary dispenser cathode

Characteristics ($f = 7.1 \dots 8.5$ GHz, $P_2 = 36$ dBm)

		min	nom	max	
Power gain	V_p	45	46	47	dB
Power gain slope (load VSWR ≤ 1.2)	$\Delta V_p / \Delta f$		0.005		dB/MHz
3rd order intercept point	I_{P3}	51			dBm
Cold VSWR	s			1.8	²⁾
Cold attenuation	α	80			dB

Operating characteristics

Frequency range	f	7.1 ... 8.5	GHz
Output power	P_2	36	dBm
Power gain	V_p	≈ 46	dB
Collector 1 voltage	U_{C1}	2000	V
Collector 2 voltage	U_{C2}	330	V
Helix voltage	U_H	4400	V
Grid 2 voltage	U_{G2}	2800 ... 3400	V
Cathode current	I_k	≈ 100	mA
Helix current	I_H	≈ 0.5	mA
Grid 2 current	I_{G2}	$\leq \pm 0.2$	mA
Noise figure	NF	≈ 22	dB
AM/PM conversion	K_c	≈ 0.4	³⁾ dB ²⁾
Intermodulation product ($P_{SCL} = 33$ dBm)	d_{32}	≈ 38	dB

¹⁾ If the maximum variation of the heater voltage exceeds the absolute limits of ± 0.2 V, the operating performance of the tube will be impaired and its life shortened.

²⁾ At input and output of the cold tube in the frequency band 7.1 to 8.5 GHz.

³⁾ AM/PM conversion is the phase shift of the RF output signal when changing the input power by 1 dB.

Maximum ratings (absolute values)

Cold collector 1 voltage	U_{C10}	max	3200	V
Collector 1 voltage	U_{C1}	min	1950	V
Collector 1 voltage	U_{C1}	max	2300	V
Collector 1 dissipation	P_{C1}	max	70	W
Cold collector 2 voltage	U_{C20}	max	1500	V
Collector 2 voltage	U_{C2}	min	300	V
Collector 2 voltage	U_{C2}	max	900	V
Collector 2 dissipation	P_{C2}	max	80	W
Cold helix voltage	U_{H0}	max	4800	V
Helix voltage	U_H	max	4600	V
Helix current	I_H	max	3	mA ¹⁾
Grid 2 voltage	U_{G2}	max	3600	V
Grid 2 current	I_{G2}	max	-0.2/+0.5	mA
Cathode current	I_k	max	130	mA
Load reflection	P_{rh}	max	3	W
Output power	P_2	max	10	W
Pulse output power ($t_{on} \leq 50$ ms, $D \leq 30\%$)	P_{2p}	max	30	W
Case temperature	t_{case}	max	90	$^{\circ}\text{C}^{2)}$
Ambient temperature	t_{amb}	min	-20	$^{\circ}\text{C}$
Ambient temperature	t_{amb}	max	70	$^{\circ}\text{C}$
Storage temperature	t_{stg}	min	-40	$^{\circ}\text{C}$
Storage temperature	t_{stg}	max	75	$^{\circ}\text{C}$
Storage life		max	5	years ³⁾
Height above mean sea level		max	4500	m

For operating instructions and detailed data refer to performance specifications.

¹⁾ Trip level for helix overcurrent protection circuit.

²⁾ Measured at the temperature reference point (see outline drawing).

³⁾ Refer to warranty conditions.

Outline drawing RW 290

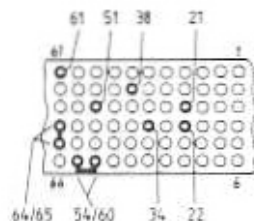
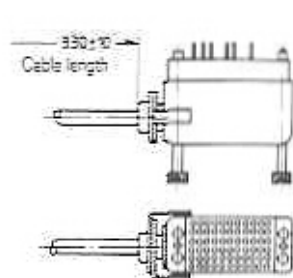
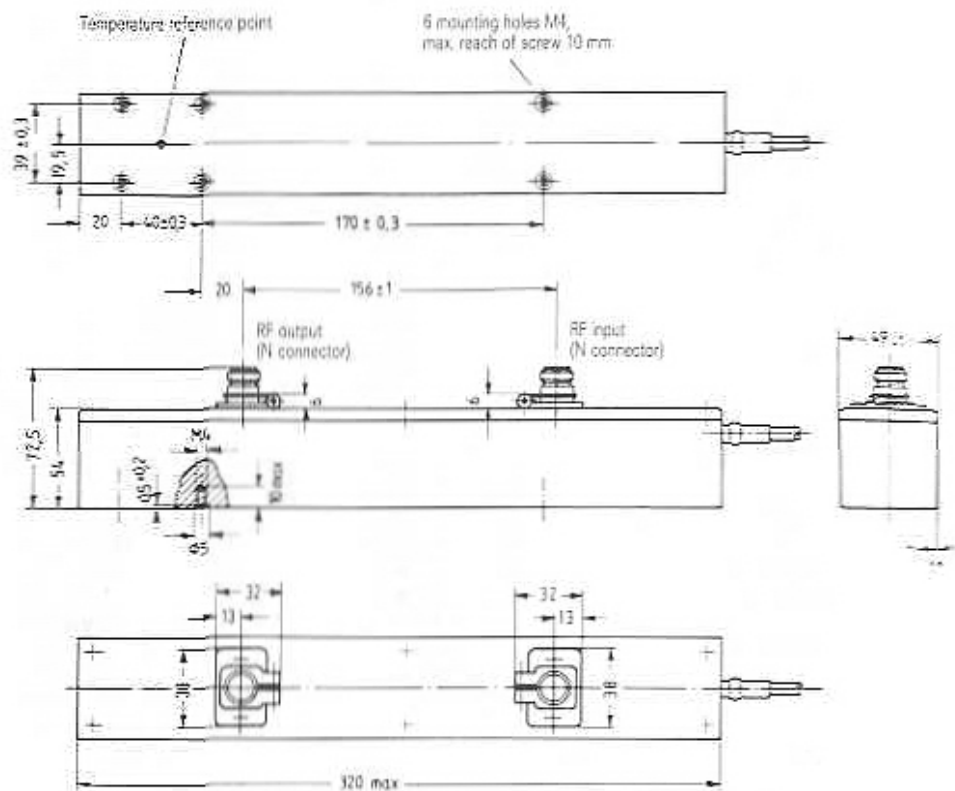

- 22 = heater (+)
- 21 = heater (-), cathode
- 38 = grid 2
- 51 = collector 1
- 34 = collector 2
- 64/65 = helix ground
- 54/60 = interlock circuit
- 61 = temperature compensation

Dimensions in mm

Power TWT preferably for analog radio link systems in the frequency band 10.7 to 11.7 GHz. RW 1125 supplies an output power of 22 W at a power gain of 40 dB.

The use of a two-stage collector enables high efficiency to be achieved. Heat dissipation is independent of the RF input power, consequently the temperature will not increase if the RF input power falls. The PPM structure consists of samarium cobalt magnet rings. The RF power is coupled in and out by way of coaxial connectors.

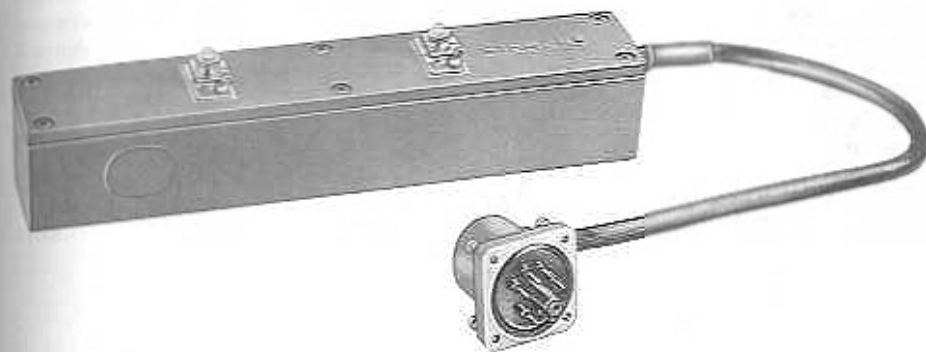

Traveling wave tube RW 1125

- Weight
- Dimensions of tube
- Dimensions of packing
- RF connector
- Mounting position

Ordering code Q41-X3294

- approx. 1.6 kg net, approx. 2.9 kg gross
- approx. 45 mm × 47.5 mm × 265 mm
- approx. 210 mm × 155 mm × 460 mm
- Siemens coaxial connector 1.4/4.4 (50 Ω)¹⁾
- any

¹⁾ Coaxial adapters to SMA are available

Heating

Heater voltage	U_F	6.3 ± 0.2	V ¹⁾
Heater current	I_F	≈ 0.55	A
Preheating time	t_h	≥ 60	s

indirectly heated by dc (+ pole to cathode)
metal capillary dispenser cathode

Characteristics ($f = 10.7 \dots 11.7$ GHz, $P_2 = 22$ W)	min	nom	max	
Power gain	V_p	40		dB
Power gain slope (load VSWR ≤ 1.2)	$\Delta V_p / \Delta f$	0.005		dB/MHz
Cold VSWR	s		1.8	²⁾
Cold attenuation	α	80		dB

Operating characteristics

Frequency range	f	10.7 ... 11.7	10.7 ... 11.7	GHz
Output power	P_2	22	11	W
Input power	P_1	2 (± 1 dB)	1 (± 1 dB)	mW
Collector 1 voltage	U_{C1}	1450	1350	V
Collector 2 voltage	U_{C2}	700	650	V
Helix voltage	U_H	3250	3150	V
Grid 2 voltage	U_{G2}	2300 ... 2900	1900 ... 2500	V
Cathode current	I_K	≤ 55	≤ 45	mA
Helix current	I_H	≈ 1	≈ 1	mA
Grid 2 current	I_{G2}	$\leq \pm 0.1$	$\leq \pm 0.1$	mA
Noise figure	NF	≈ 25	≈ 25	dB
AM/PM conversion	K_p	≈ 4	≈ 3.5	1/dB ³⁾

¹⁾ If the maximum variation of the heater voltage exceeds the absolute limits of ± 0.2 V, the operating performance of the tube will be impaired and its life shortened.

²⁾ At input and output of the cold tube in the frequency band 10.7 to 11.7 GHz.

³⁾ AM/PM conversion is the phase shift of the RF output signal when changing the input power by 1 dB.

Maximum ratings (absolute values):

Cold collector 1 voltage	$U_{C1,0}$	max	3000	V
Collector 1 voltage	U_{C1}	max	1800	V ¹⁾
Collector 1 dissipation	P_{C1}	max	55	W
Cold collector 2 voltage	$U_{C2,0}$	max	1000	V
Collector 2 voltage	U_{C2}	max	800	V ²⁾
Collector 2 dissipation	P_{C2}	max	50	W
Cold helix voltage	$U_{H,0}$	max	3800	V
Helix voltage	U_H	max	3600	V
Helix current	I_H	max	4	mA ³⁾
Grid 2 voltage	U_{G2}	max	3600	V
Grid 2 current	I_{G2}	max	± 0.3	mA
Cathode current	I_K	max	60	mA
Load reflection	P_{ref}	max	5	W
Case temperature	t_{case}	max	100	°C ⁴⁾
Ambient temperature	t_{amb}	min	-30	°C
Ambient temperature	t_{amb}	max	65	°C
Storage temperature	t_{top}	min	-40	°C
Storage temperature	t_{top}	max	75	°C
Storage life		max	5	years ⁵⁾
Height above mean sea level		max	4500	m

For operating instructions and detailed data refer to performance specifications.

¹⁾ The collector 1 voltage may not fall below the operating value by more than 50 V (including setting accuracy and voltage stability).

²⁾ The collector 2 voltage may not fall below the operating value by more than 30 V (including setting accuracy and voltage stability).

³⁾ Trip level for helix overcurrent protection circuit.

⁴⁾ Measured at the temperature reference point (see outline drawing).

⁵⁾ Refer to warranty conditions.

Outline drawing RW 1125

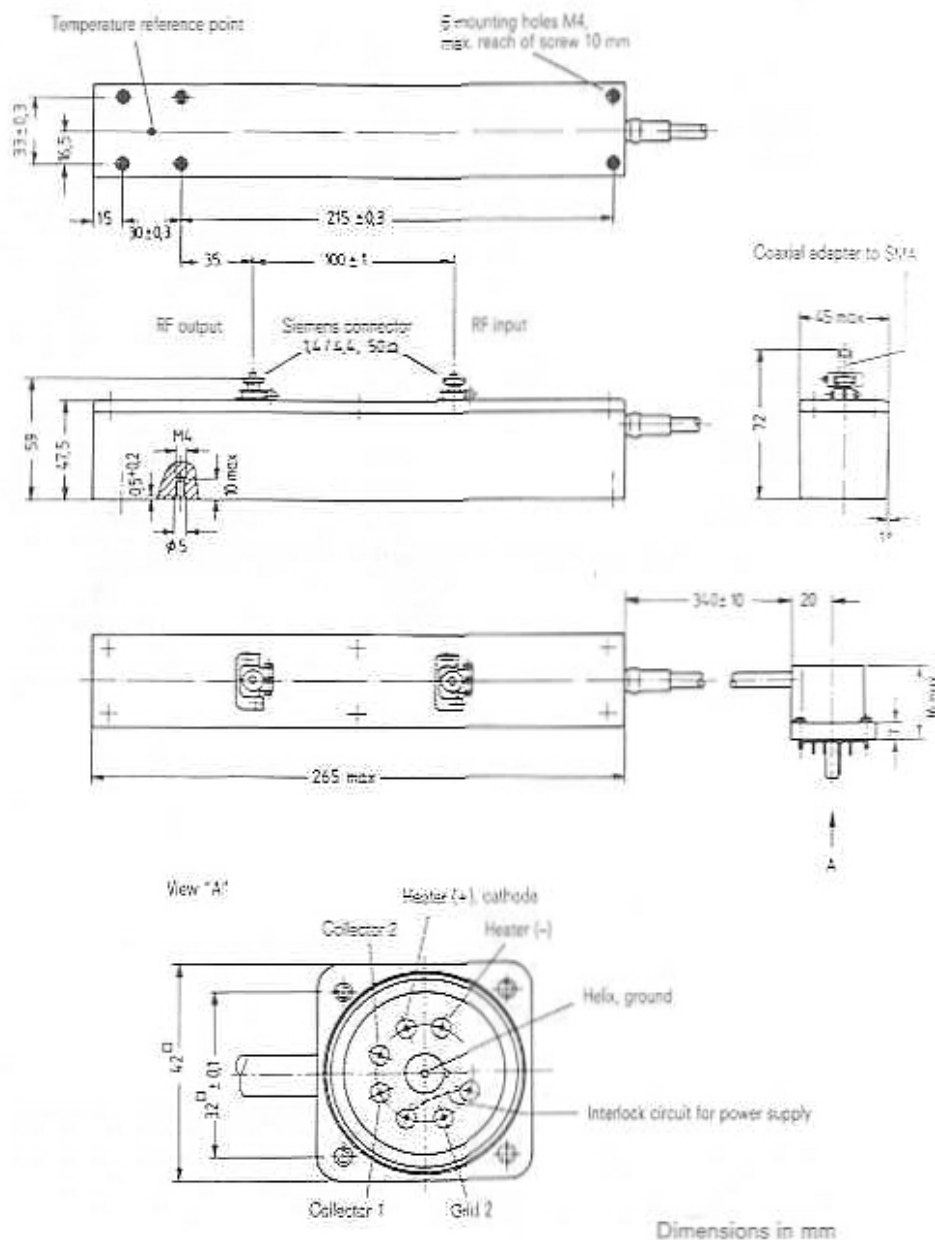

Power TWT preferably for analog and 8 PSK digital radio link systems in the frequency band 10.7 to 12.7 GHz.

RW 1125 D supplies an output power of 15 W at a gain of 40 dB.

The use of a two-stage collector enables high efficiency to be achieved. Heat dissipation is independent of the RF input power, consequently the temperature will not increase if the RF input power falls. The PPM structure consists of samarium cobalt magnet rings. The RF power is coupled in and out by way of coaxial connectors.

Power supplies RWN 120 or RWN 121 with control unit BT 300 are available for tube operation. The rated input voltage ranges from 24 to 60 V without switching. When operated with an RF output power \geq 12 W the rated input voltage of the power supply is between 48 and 60 V.

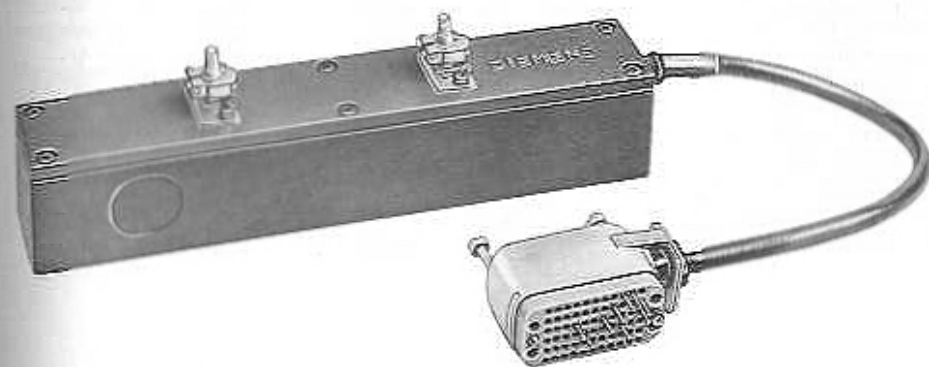

Traveling wave tube RW 1125 D

- Weight
- Dimensions of tube
- Dimensions of packing
- RF connector
- Mounting position

Ordering code Q41-X3281

- approx. 1.6 kg net; approx. 2.9 kg gross
- approx. 45 mm x 47.5 mm x 265 mm
- approx. 210 mm x 155 mm x 460 mm
- SMA connector (female)
- any

Heating

Heater voltage	U_F	6.3 ± 0.2	V ¹⁾
Heater current	I_F	≈ 0.55	A
Preheating time	t_h	≥ 60	s

indirectly heated by dc (+pole to cathode)
metal capillary dispenser cathode

Characteristics ($f = 10.7 \dots 12.7$ GHz, $P_2 = 15$ W)	min	nom	max	
Power gain	V_p	40		dB
Power gain slope (load VSWR ≤ 1.2)	$\Delta V_p / \Delta f$	0.005		dB/MHz
Cold VSWR	s		1.8	²⁾
Cold attenuation	α	80		dB

Operating characteristics

Application		Analog	Digital 8 PSK	
Frequency range	f	10.7 ... 12.7	10.7 ... 12.7	GHz
Output power	P_2	15	3	W
Power gain	V_p	40 ± 1	≈ 45	dB
Collector 1 voltage	U_{C1}	1450	1450	V
Collector 2 voltage	U_{C2}	700	700	V
Helix voltage	U_H	3200	3200	V
Grid 2 voltage	U_{G2}	2100 ... 2700	2300 ... 2950	V
Cathode current	I_K	≤ 50	55 ± 2	mA
Helix current	I_H	≈ 1	≈ 1	mA
Grid 2 current	I_{G2}	$\leq \pm 0.1$	$\leq \pm 0.1$	mA
Noise figure	NF	≈ 25	≈ 25	dB
AM/PM conversion	k_D	≈ 3.5	≈ 1.5	%/dB ³⁾
3rd order intercept point	IP_3	≥ 46	≥ 45.5	dBm

¹⁾ If the maximum variation of the heater voltage exceeds the absolute limits of ± 0.2 V, the operating performance of the tube will be impaired and its life shortened.

²⁾ At input and output of the cold tube in the frequency band 10.7 to 12.7 GHz.

³⁾ AM/PM conversion is the phase shift of the RF output signal when changing the input power by 1 dB.

Maximum ratings (absolute values)

Cold collector 1 voltage	U_{C1a}	max	3000	V
Collector 1 voltage	U_{C1}	max	1800	V ¹⁾
Collector 1 dissipation	P_{C1}	max	55	W
Cold collector 2 voltage	U_{C2a}	max	1000	V
Collector 2 voltage	U_{C2}	max	800	V ²⁾
Collector 2 dissipation	P_{C2}	max	50	W
Cold helix voltage	U_{L0}	max	3800	V
Helix voltage	U_L	max	3600	V
Helix current	I_H	max	4	mA ³⁾
Grid 2 voltage	U_{G2}	max	3600	V
Grid 2 current	I_{G2}	max	± 0.3	mA
Cathode current	I_K	max	60	mA
Load reflection	P_{ref}	max	5	W
Case temperature	t_{case}	max	100	°C ⁴⁾
Ambient temperature	t_{amb}	min	-30	°C
Ambient temperature	t_{amb}	max	65	°C
Storage temperature	t_{stg}	min	-40	°C
Storage temperature	t_{stg}	max	75	°C
Storage life		max	5	years ⁵⁾
Height above mean sea level		max	4500	m

For operating instructions and detailed data refer to performance specifications.

¹⁾ The collector 1 voltage may not fall below the operating value by more than 50 V (including setting accuracy and voltage stability).

²⁾ The collector 2 voltage may not fall below the operating value by more than 30 V (including setting accuracy and voltage stability).

³⁾ Trip level for helix overcurrent protection circuit.

⁴⁾ Measured at the temperature reference point (see outline drawing).

⁵⁾ Refer to warranty conditions.

Outline drawing RW 1125 D

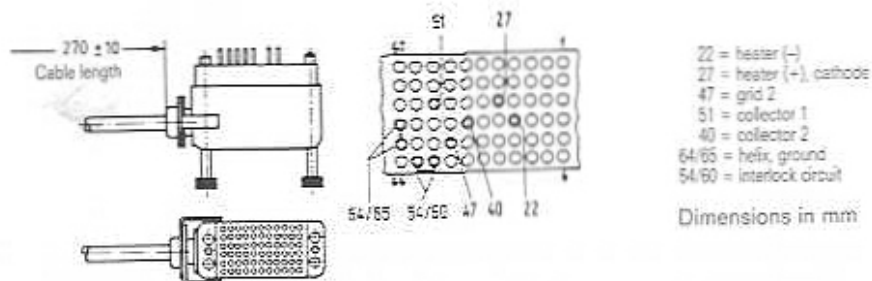
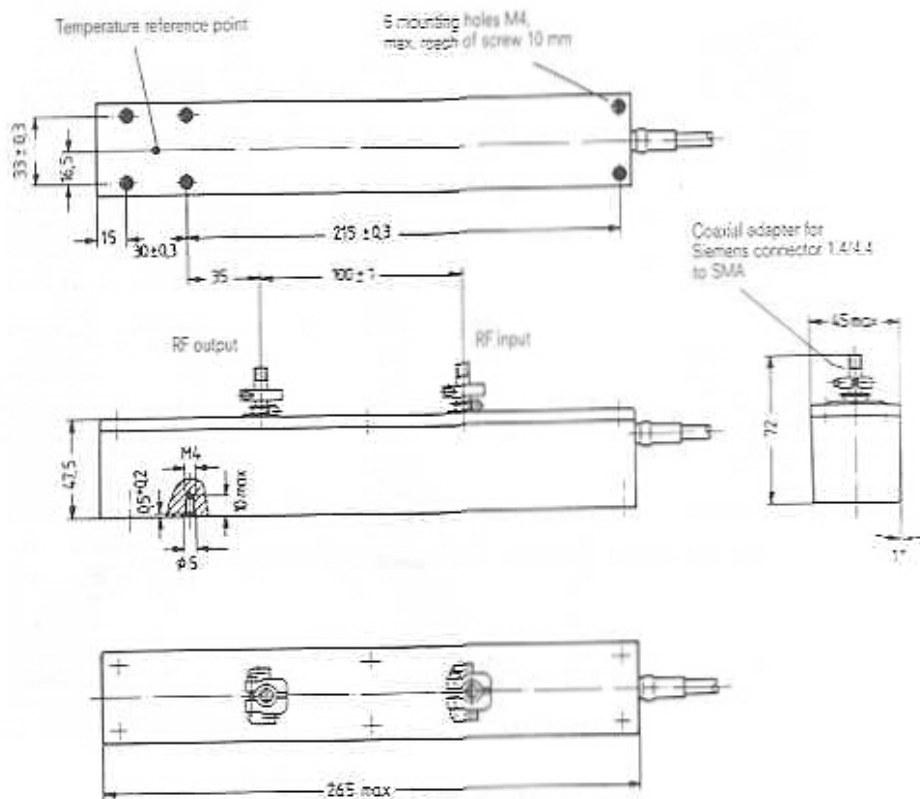

Power TWT preferably for analog radio link systems in the frequency band 10.7 to 13.25 GHz. RW 1125 G supplies an output power of 20 W at a gain of 41 dB.

The use of a two-stage collector enables high efficiency to be achieved. Heat dissipation is independent of the RF input power, consequently the temperature will not increase if the RF input power falls. The PPM structure consists of samarium cobalt magnet rings. The RF power is coupled in and out by way of coaxial connectors.

Power supplies RWN 120 or RWN 121 with control unit BT 300 are available for tube operation. The rated input voltage ranges from 24 to 60 V without switching. When operated with an RF output power ≥ 12 W the rated input voltage range of the power supply is between 48 and 60 V.

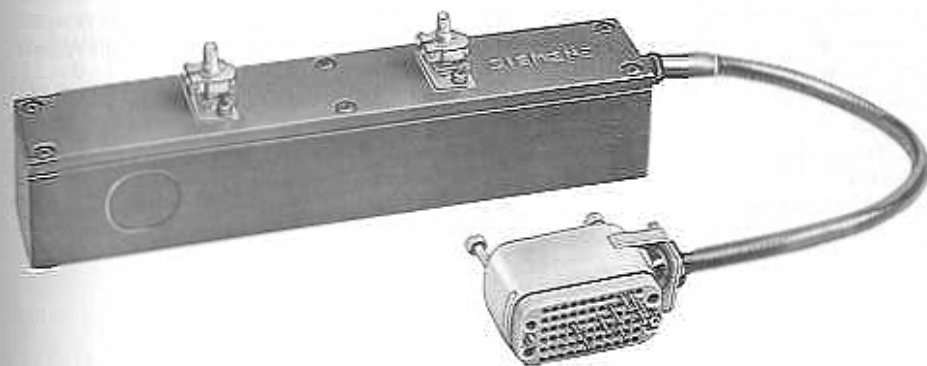

Traveling wave tube RW 1125 G

- Weight
- Dimensions of tube
- Dimensions of packing
- RF connector
- Mounting position

Ordering code Q41-X3301

- approx. 1.6 kg net, approx. 2.9 kg gross
- approx. 45 mm × 47.5 mm × 265 mm
- approx. 210 mm × 155 mm × 460 mm
- SMA connector (female)
- any

Heating

Heater voltage	U_f	6.3 ± 0.2	V ¹⁾
Heater current	I_f	≈ 0.55	A
Preheating time	t_p	≥ 60	s

indirectly heated by dc (+ pole to cathode)
metal capillary dispenser cathode

Characteristics ($f = 10.7 \dots 13.25$ GHz, $P_2 = 20$ W)

	min	nom	max	
Power gain		41		dB
Power gain slope (load VSWR ≤ 1.2)		0.005		dB/MHz
Cold VSWR			1.8	²⁾
Cold attenuation	α	80		dB

Operating characteristics

Frequency range	f	10.7 ... 13.25	GHz
Output power	P_2	20	W
Input power	P_1	1.6 (± 0.5 dB)	mW
Collector 1 voltage	U_{C1}	1450	V
Collector 2 voltage	U_{C2}	700	V
Helix voltage	U_H	3200	V
Grid 2 voltage	U_{G2}	2300 ... 2900	V
Cathode current	I_K	≤ 55	mA
Helix current	I_H	≈ 1	mA
Grid 2 current	I_{G2}	$\leq \pm 0.1$	mA
Noise figure	NF	≈ 25	dB
AM/PM conversion	k_p	≈ 3.5	%/dB ³⁾

¹⁾ If the maximum variation of the heater voltage exceeds the absolute limits of ± 0.2 V, the operating performance of the tube will be impaired and its life shortened.

²⁾ At input and output of the cold tube in the frequency band 10.7 to 13.25 GHz.

³⁾ AM/PM conversion is the phase shift of the RF output signal when changing the input power by 1 dB.

Maximum ratings (absolute values)

Cold collector 1 voltage	U_{C1a}	max	3000	V
Collector 1 voltage	U_{C1}	max	1800	V ¹⁾
Collector 1 dissipation	P_{C1}	max	55	W
Cold collector 2 voltage	U_{C2a}	max	1000	V
Collector 2 voltage	U_{C2}	max	800	V ²⁾
Collector 2 dissipation	P_{C2}	max	50	W
Cold helix voltage	U_{Ha}	max	3800	V
Helix voltage	U_H	max	3600	V
Helix current	I_H	max	4	mA ³⁾
Grid 2 voltage	U_{G2}	max	3600	V
Grid 2 current	I_{G2}	max	± 0.3	mA
Cathode current	I_K	max	60	mA
Load reflection	P_{rl}	max	5	W
Case temperature	t_{case}	max	100	°C ⁴⁾
Ambient temperature	t_{amb}	min	-30	°C
Ambient temperature	t_{amb}	max	65	°C
Storage temperature	t_{sto}	min	-40	°C
Storage temperature	t_{sto}	max	75	°C
Storage life		max	5	years ⁵⁾
Height above mean sea level		max	4500	m

For operating instructions and detailed data refer to performance specifications.

¹⁾ The collector 1 voltage may not fall below the operating value by more than 50 V (including setting accuracy and voltage stability).

²⁾ The collector 2 voltage may not fall below the operating value by more than 30 V (including setting accuracy and voltage stability).

³⁾ Trip level for helix overcurrent protection circuit.

⁴⁾ Measured at the temperature reference point (see outline drawing).

⁵⁾ Refer to warranty conditions.

Outline drawing RW 1125 G

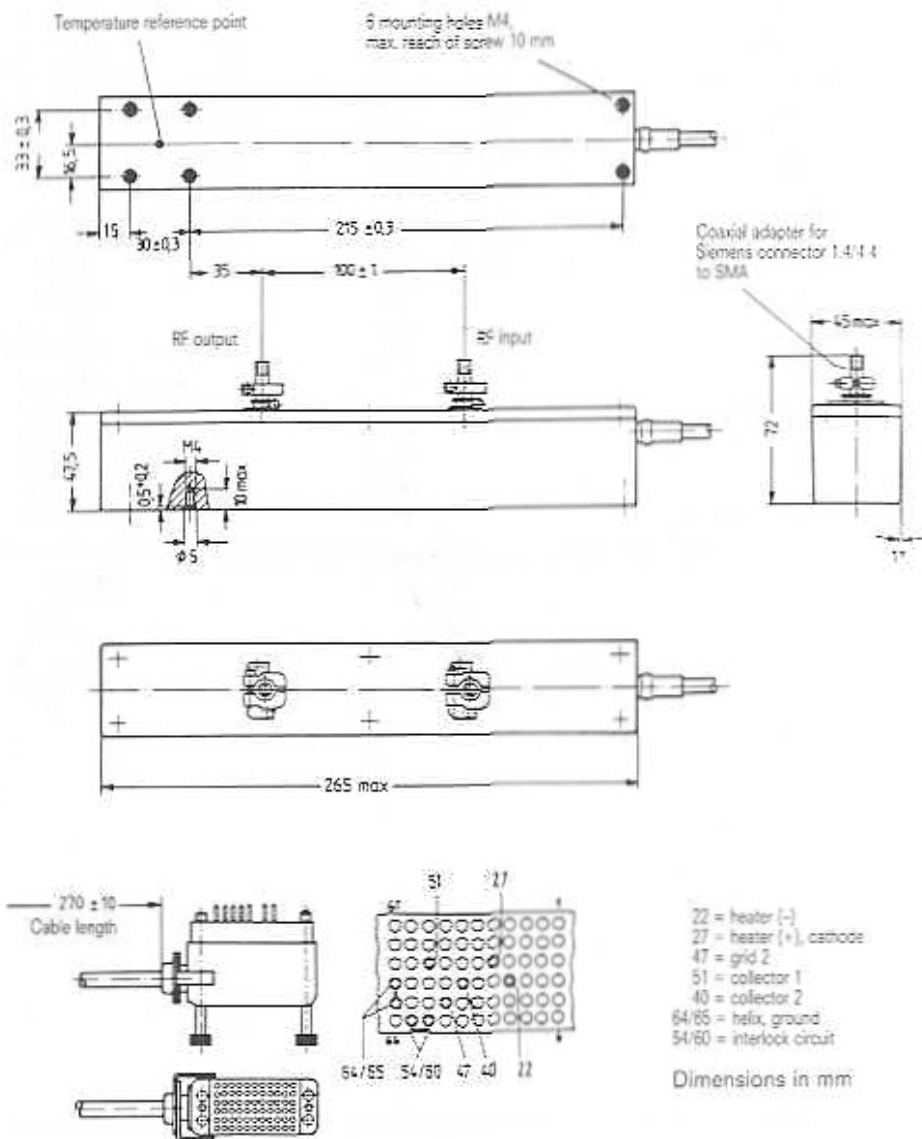

Highly linear power TWT preferably for AM TV radio link systems in the frequency band 11.7 to 15.25 GHz.

The tube supplies a continuous output power of up to 5 W and features an average power gain of 37.5 dB. The 3rd order intercept point is at least 51.4 dBm. Within the ambient temperature range the output power is kept constant by means of compensation.

The use of a two-stage collector improves efficiency. The PPM structure consists of samarium cobalt magnet rings. The RF output power is coupled in and out by way of coaxial connectors. Dissipation heat is removed by conduction.

Power supplies RWN 320 or RWN 321 with control unit BT 300 are available for tube operation. The rated input voltage ranges from 24 to 60 V without switching.

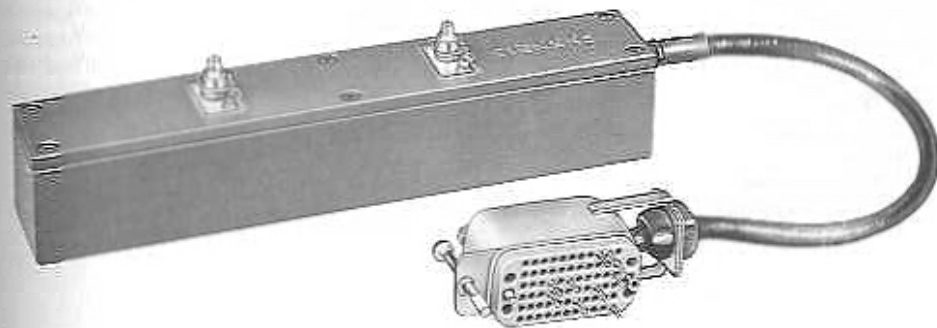

Traveling wave tube RW 1127

- Weight
- Dimensions of tube
- Dimensions of packing
- RF connector
- Mounting position

Ordering code Q41-X3312

- approx. 1.6 kg net, approx. 2.9 kg gross
- approx. 45 mm × 47.5 mm × 265 mm
- approx. 210 mm × 155 mm × 460 mm
- SMA connector (female)
- any

Heating

Heater voltage	U_F	6.3 ± 0.2	V ¹⁾
Heater current	I_F	≈ 0.55	A
Preheating time	t_H	≥ 60	s

indirectly heated by dc (+pole to cathode)
metal capillary dispenser cathode

Characteristics ($f = 11.7 \dots 13.25$ GHz, $P_{2SY} = 3.5$ W)	min	nom	max		
Power gain	V_D	35	37.5	40	dB
Power gain slope (load VSWR ≤ 1.2)	$\Delta V_D / \Delta f$		0.01		dB/MHz
3rd order intercept point	IP_3	51.4			dBm
Cold VSWR	s		1.5		°)
Cold attenuation	α	80			dB

Operating characteristics

Frequency range	f	11.7 ... 13.25	GHz
Output power, sync. level	P_{2SY}	3.5	W
Power gain	V_D	≈ 37.5	dB
Collector 1 voltage	U_{C1}	2400	V
Collector 2 voltage	U_{C2}	400	V
Helix voltage	U_H	5000	V
Grid 2 voltage	U_{G2}	3600 ... 4600	V
Cathode current	I_K	≈ 115	mA
Helix current	I_H	≈ 0.5	mA
Grid 2 current	I_{G2}	$\leq \pm 0.2$	mA
Noise figure	NF	≈ 25	dB
AM/PM conversion	K_P	≈ 0.4	°/dB ²⁾
3-tone intermodulation ratio	δ_{IM3}	≥ 60	dB ³⁾

¹⁾ If the maximum variation of the heater voltage exceeds the absolute limits of ± 0.2 V, the operating performance of the tube will be impaired and its life shortened.

²⁾ At input and output of the cold tube in the frequency band 11.7 to 13.25 GHz.

³⁾ AM/PM conversion is the phase shift of the RF output signal when changing the input power by 1 dB.

⁴⁾ Measured in accordance with specification FTZ 176 Pt 2 of the German Federal Postal Administration with distortion-free input signal; level diagram: $f_1: -8$ dB, $f_2: -10$ dB, $f_3: -16$ dB.

Maximum ratings (absolute values)

Cold collector 1 voltage	U_{C10}	max	3300	V
Collector 1 voltage	U_{C1}	min	2350	V
Collector 1 voltage	U_{C1}	max	3000	V
Collector 1 dissipation	P_{C1}	max	60	W
Cold collector 2 voltage	U_{C20}	max	1500	V
Collector 2 voltage	U_{C2}	min	370	V
Collector 2 voltage	U_{C2}	max	900	V
Collector 2 dissipation	P_{C2}	max	80	W
Cold helix voltage	U_{H0}	max	5600	V
Helix voltage	U_H	max	5400	V
Helix current	I_H	max	3	mA ¹⁾
Grid 2 voltage	U_{G2}	max	5400	V
Grid 2 current	I_{G2}	max	-0.2/+0.5	mA
Cathode current	I_K	max	130	mA
Load reflection	P_r	max	3	W
Output power	P_2	max	5	W
Case temperature	t_{case}	max	90	°C ²⁾
Ambient temperature	t_{amb}	min	-20	°C
Ambient temperature	t_{amb}	max	70	°C
Storage temperature	t_{stg}	min	-40	°C
Storage temperature	t_{stg}	max	75	°C
Storage life		max	5	years ³⁾
Height above mean sea level		max	4500	m

For operating instructions and detailed data refer to performance specifications.

¹⁾ Trip level for helix overcurrent protection circuit.

²⁾ Measured at the temperature reference point (see outline drawing).

³⁾ Refer to guaranty conditions.

Outline drawing RW 1127

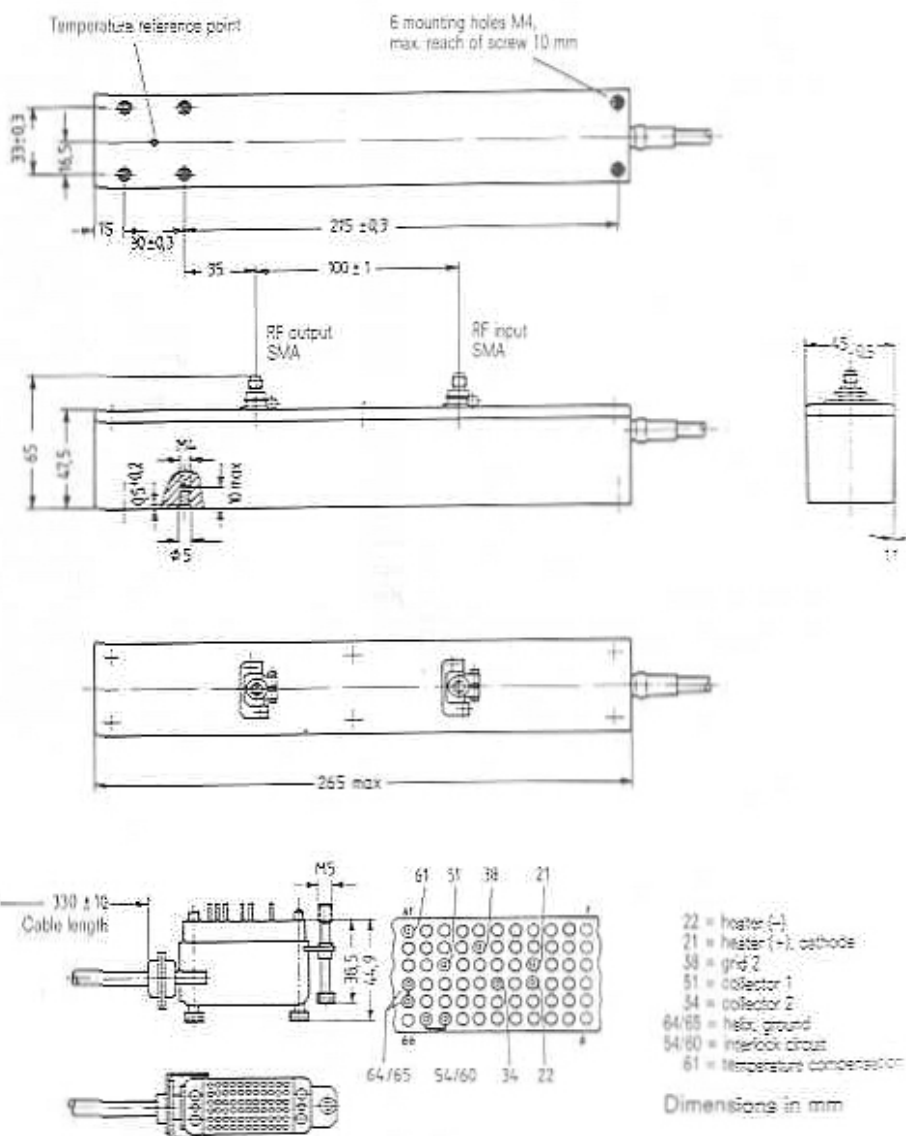

Highly linear power TWT preferably for 16 QAM digital radio link systems in the frequency band 10.7 to 11.7 GHz.

The tube supplies a continuous output power of up to 8 W and a peak output power of up to 15 W; the average power gain amounts to 46 dB. The 3rd order intercept point is at least 48 dBm. Within the ambient temperature range the output power is kept constant by means of compensation.

The use of a two-stage collector improves efficiency. The PPM structure consists of samarium cobalt magnet rings. The RF power is coupled in and out by way of coaxial connectors.

Dissipation heat is removed by conduction.

Power supplies RWN 220 or RWN 221 with control unit BT 300 are available for tube operation. The rated input voltage ranges from 24 to 60 V without switching.

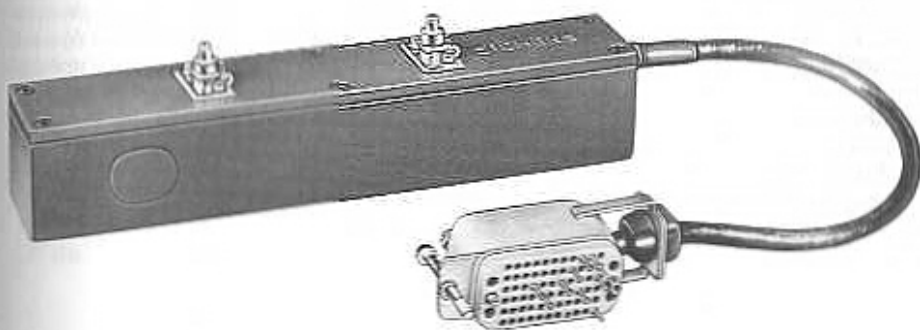

Traveling wave tube 1136

- Weight
- Dimensions of tube
- Dimensions of packing
- RF connector
- Mounting position

Ordering code Q41-X3314

- approx. 1.6 kg net, approx. 2.9 kg gross
- approx. 45 mm × 47.5 mm × 265 mm
- approx. 210 mm × 155 mm × 460 mm
- SMA connector (female)
- any

Heating

Heater voltage	U_F	6.3 ± 0.2	V ¹⁾
Heater current	I_F	≈ 0.55	A
Preheating time indirectly heated by dc (+ pole to cathode) metal capillary dispenser cathode	t_h	≥ 60	s

Characteristics ($f = 10.7 \dots 11.7$ GHz, $P_2 = 35$ dBm)	min	nom	max		
Power gain	V_o	45	46	47	dB
Power gain slope (load VSWR ≤ 1.2)	$\Delta V_o / \Delta f$		0.005		dB/MHz
3rd order intercept point	IP_3	48			dBm
Cold VSWR	s		1.8		²⁾
Cold attenuation	α	80			dB

Operating characteristics

Frequency range	f	10.7 ... 11.7	10.7 ... 11.7	GHz
Output power	P_2	35	37	dBm
Power gain	V_o	≈ 46	≈ 44.5	dB
Collector 1 voltage	U_{C1}	1350	1450	V
Collector 2 voltage	U_{C2}	360	400	V
Helix voltage	U_H	3250	3250	V
Grid 2 voltage	U_{G2}	2100 ... 2900	2100 ... 2900	V
Cathode current	I_K	≈ 68	≈ 63	mA
Helix current	I_H	≈ 0.5	≈ 0.5	mA
Grid 2 current	I_{G2}	$\leq \pm 0.2$	$\leq \pm 0.2$	mA
Noise figure	NF	≈ 25	≈ 25	dB
AM/PM conversion	k_p	≈ 0.6	≈ 1	%/dB ³⁾
Intermodulation product ($P_{SCL} = 32$ dBm)	d_{12}	≈ 33		dB
($P_{SCL} = 34$ dBm)	d_{12}		≈ 28	dB

¹⁾ If the maximum variation of the heater voltage exceeds the absolute limits of ± 0.2 V, the operating performance of the tube will be impaired and its life shortened.

²⁾ At input and output of the cold tube in the frequency range 10.7 to 11.7 GHz.

³⁾ AM/PM conversion is the phase shift of the RF output signal when changing the input power by 1 dB.

Maximum ratings (absolute values)

Cold collector 1 voltage	U_{C1c}	max	2700	V
Collector 1 voltage	U_{C1}	min	1300	V
Collector 1 voltage	U_{C1}	max	1800	V
Collector 1 dissipation	P_{C1}	max	50	W
Cold collector 2 voltage	U_{C2c}	max	1600	V
Collector 2 voltage	U_{C2}	min	330	V
Collector 2 voltage	U_{C2}	max	900	V
Collector 2 dissipation	P_{C2}	max	40	W
Cold helix voltage	U_{Hc}	max	3800	V
Helix voltage	U_H	max	3600	V
Helix current	I_H	max	4	mA ¹⁾
Grid 2 voltage	U_{G2}	max	3600	V
Grid 2 current	I_{G2}	max	-0.2/+0.5	mA
Cathode current	I_K	max	80	mA
Load reflection	P_{10}	max	3	W
Output power	P_2	max	8	W
Pulse output power ($t_{imp} \leq 50$ ms, $D \leq 30$ %)	P_{2D}	max	15	W
Case temperature	t_{case}	max	90	°C ²⁾
Ambient temperature	t_{amb}	min	-20	°C
Ambient temperature	t_{amb}	max	65	°C
Storage temperature	t_{sto}	min	-40	°C
Storage temperature	t_{sto}	max	75	°C
Storage life		max	5	years ³⁾
Height above mean sea level		max	4500	m

For operating instructions and detailed data refer to performance specifications.

¹⁾ Trip level for helix overcurrent protection circuit.

²⁾ Measured at the temperature reference point (see outline drawing).

³⁾ Refer to guaranty conditions.

Outline drawing RW 1136

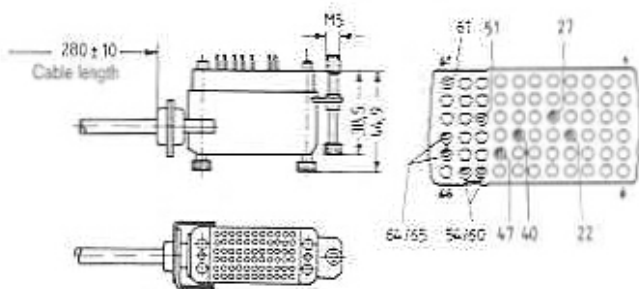
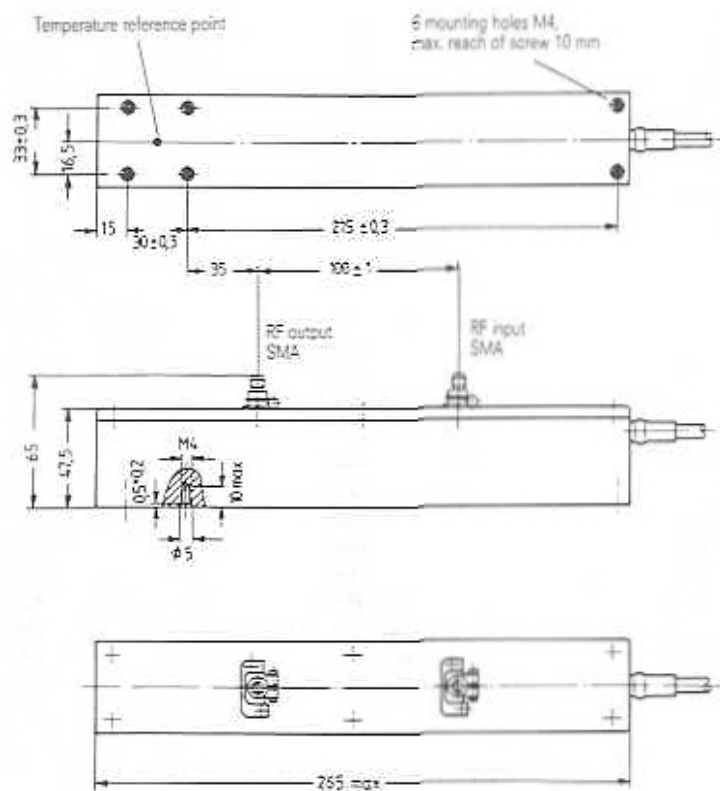

- 22 = heater (-)
- 27 = heater (+), cathode
- 47 = grid 2
- 51 = collector 1
- 40 = collector 2
- 64/65 = helix, ground
- 54/60 = interlock circuit
- 61 = temperature compensator

Dimensions in mm

Highly linear power TWT preferably for 64 QAM digital radio link systems in the frequency band 10.7 to 11.7 GHz.

The tube supplies a continuous output power of up to 10 W and a peak output power of up to 30 W; the average power gain amounts to 46 dB. The 3rd order intercept point is at least 51 dBm. Within the ambient temperature range the output power is kept constant by means of compensation.

The use of a two-stage collector improves efficiency. The PPM structure consists of samarium cobalt magnet rings. The RF power is coupled in and out by way of coaxial connectors.

Dissipation heat is removed by conduction.

Power supplies RWN 320 or RWN 321 with control unit BT 300 are available for tube operation. The rated input voltage ranges from 24 to 60 V without switching.

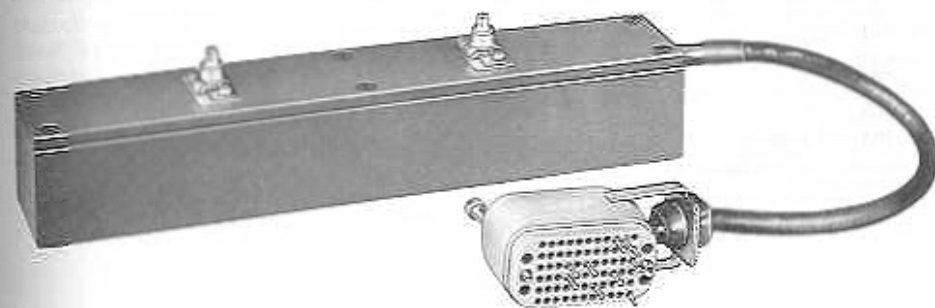

Traveling wave tube RW 2135

- Weight
- Dimensions of tube
- Dimensions of packing
- RF connector
- Mounting position

Ordering code Q41-X3307

- approx. 1.8 kg net, approx. 3.1 kg gross
- approx. 45 mm × 47.5 mm × 205 mm
- approx. 210 mm × 155 mm × 460 mm
- SMA connector (female)
- any

Heating

Heater voltage	U_F	6.3 ± 0.2	V ¹⁾
Heater current	I_F	≈ 0.55	A
Preheating time	t_h	≥ 60	s

indirectly heated by dc (+ pole to cathode)
metal capillary dispenser cathode

Characteristics ($f = 10.7 \dots 11.7$ GHz, $P_2 = 36$ dBm)	min	nom	max		
Power gain	V_p	45	46	47	dB
Power gain slope (load VSWR ≤ 1.2)	$\Delta V_p / \Delta f$		0.005		dB/MHz
3rd order intercept point	I_{P_3}	51			dBm
Cold VSWR	s			1.8	²⁾
Cold attenuation	a	80			dB

Operating characteristics

Frequency range	f	10.7 ... 11.7	10.7 ... 11.7	GHz
Output power	P_2	36	38	dBm
Power gain	V_p	≈ 46	≈ 46	dB
Collector 1 voltage	U_{C1}	2400	2400	V
Collector 2 voltage	U_{C2}	400	400	V
Helix voltage	U_H	5100	5100	V
Grid 2 voltage	U_{G2}	3430 ... 4300	3430 ... 4300	V
Cathode current	I_K	≈ 110	≈ 110	mA
Helix current	I_H	≈ 0.5	≈ 0.5	mA
Grid 2 current	I_{G2}	$\leq \pm 0.2$	$\leq \pm 0.2$	mA
Noise figure	NF	≈ 25	≈ 25	dB
AM/PM conversion	k_p	≈ 0.5	≈ 0.8	%/dB ³⁾
Intermodulation product ($P_{SCL} = 33$ dBm)	d_{32}	≈ 38		dB
($P_{SCL} = 35$ dBm)	d_{32}		≈ 34	dB

¹⁾ If the maximum variation of the heater voltage exceeds the absolute limits of ± 0.2 V, the operating performance of the tube will be impaired and its life shortened.

²⁾ At input and output of the cold tube in the frequency band 10.7 to 11.7 GHz.

³⁾ AM/PM conversion is the phase shift of the RF output signal when changing the input power by 1 dB.

Maximum ratings (absolute values)

Cold collector 1 voltage	U_{C10}	max	3300	V
Collector 1 voltage	U_{C1}	min	2350	V
Collector 1 voltage	U_{C1}	max	3000	V
Collector 1 dissipation	P_{C1}	max	80	W
Cold collector 2 voltage	U_{C20}	max	1500	V
Collector 2 voltage	U_{C2}	min	370	V
Collector 2 voltage	U_{C2}	max	900	V
Collector 2 dissipation	P_{C2}	max	80	W
Cold helix voltage	U_{H0}	max	5600	V
Helix voltage	U_H	max	5400	V
Helix current	I_H	max	3	mA ¹⁾
Grid 2 voltage	U_{G2}	max	5400	V
Grid 2 current	I_{G2}	max	-0.2/+0.5	mA
Cathode current	I_K	max	130	mA
Load reflection	P_{rh}	max	3	W
Output power	P_2	max	10	W
Pulse output power ($t_{imp} \leq 50$ ms, $D \leq 30$ %)	P_{2D}	max	30	W
Case temperature	t_{case}	max	90	°C ²⁾
Ambient temperature	t_{amb}	min	-20	°C
Ambient temperature	t_{amb}	max	70	°C
Storage temperature	t_{stg}	min	-40	°C
Storage temperature	t_{stg}	max	75	°C
Storage life		max	5	years ³⁾
Height above mean sea level		max	4500	m

For operating instructions and detailed data refer to performance specifications.

¹⁾ Trip level for helix overcurrent protection circuit.

²⁾ Measured at the temperature reference point (see outline drawing).

³⁾ Refer to guaranty conditions.

Outline drawing RW 2135

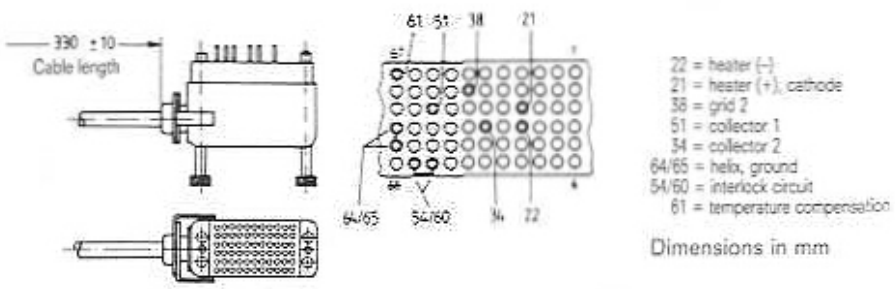
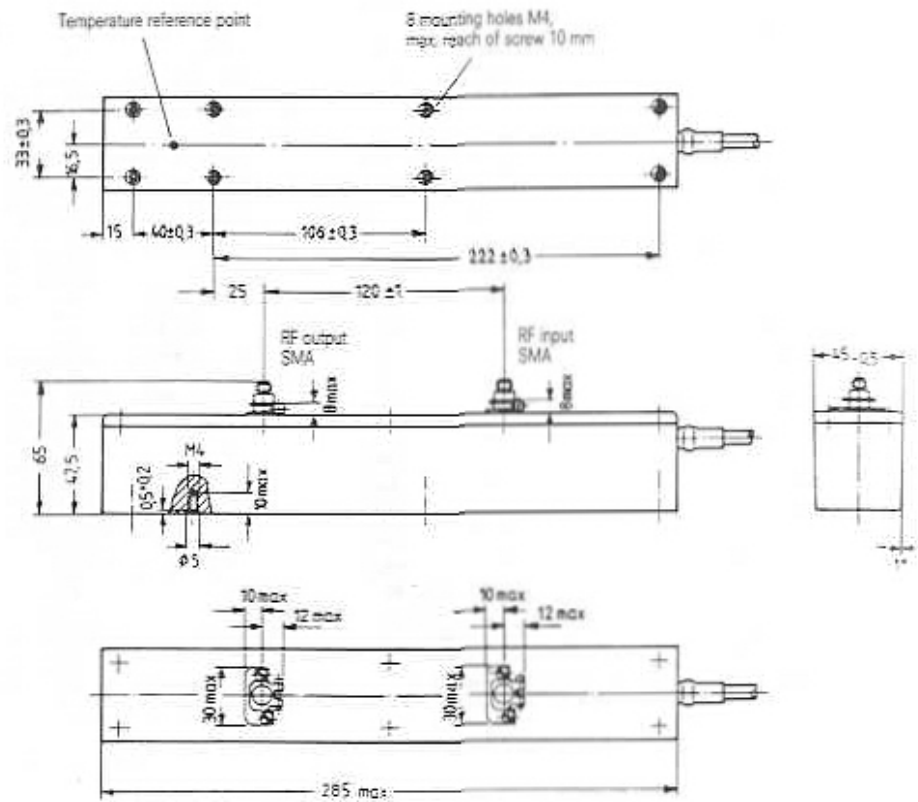

Power Supplies
for Radio Link TWTs

Power Supply Unit for Radio Link TWTs

RWN 120
RWN 121

Power supply unit to operate radio link TWTs, such as RW 89 D, RW 90 D, RW 1125 D, and RW 1125 G.

The unit is designed for a rated input voltage range between 24 V and 60 V (without switching), and includes all necessary safety, monitoring, and control functions.

The power supply can be adjusted to the individual tube operating voltages by internal switching.

The heat is dissipated by conduction via the mounting surface. With RWN 120 the grid 2 voltage is adjusted at the mounting side, with RWN 121 at the opposite side.

A plug-in control unit is additionally available, comprising power switch, standby switch, reset button, alarm and prealarm indicators, as well as outputs for remote prealarm, remote reset, cathode and helix current measurement.



Power supply unit RWN 120
Power supply unit RWN 121

Weight
Dimensions of power supply
Dimensions of packing
Low-voltage connector
High-voltage connector (female)
Mounting position

Ordering code Q87-X344
Ordering code Q87-X318

approx. 2.4 kg net, approx. 3.9 kg gross
approx. 310 mm × 50 mm × 190 mm
approx. 550 mm × 160 mm × 310 mm
D-subminiature connector, 15 pins
MIRAC 66SJ, Litton/Winchester
any

Power Supply Unit for Radio Link TWTs

RWN 120
RWN 121

Characteristics, input

Rated voltage range	U_E	24 ... 60	V dc ¹⁾
Operating voltage range	U_B	20 ... 75	V dc
Power consumption	P_B	max. 110	W
Internal input protection (pico fuse)		7	A

The input is ungrounded. Plus or minus U_B and power supply housing have to be grounded.

Warning! Turning on without grounding destroys the device.

Characteristics, outputs

(operating voltages for the tube)

Heater voltage	U_F	6.3 ± 0.2	V
Heater current	I_F	0.5 ... 0.6	A
Grid 2 voltage	U_{G2}	900 ... 2900	V ²⁾
Grid 2 current	I_{G2}	-0.1 ... +0.5	mA
Helix voltage	U_H	2150 ... 3250	V ³⁾
Helix current	I_H	max. 4	mA
Collector 1 voltage	U_{C1}	1150/1250/1350/1450	V ⁴⁾
Collector 1 current	I_{C1}	max. 40	mA ⁵⁾
Collector 2 voltage	U_{C2}	550/600/650/700	V ³⁾
Collector 2 current	I_{C2}	max. 60	mA ⁵⁾

A defective tube does not impair the power supply unit.

¹⁾ Operation of tubes RW 1125 D and RW 1125 G with an output power ≥ 12 W is only permissible within the rated input voltage range 48 to 60 V.
²⁾ Continuously adjustable at the front panel (within sub-range steps that can be set according to tube type inside the device).
³⁾ Adjustable inside the device in steps of 50 V.
⁴⁾ Can be set inside the device.
⁵⁾ The sum of collector 1 current and collector 2 current may not exceed 60 mA.

Environmental conditions

Operating temperature at front panel (see temperature reference point)	-20 ... +70	°C
Turn-on temperature	min. -20	°C
Storage temperature	-40 ... +75	°C
Relative humidity (during operation)	max. 95 (no dew precipitation)	%
Application altitude	max. 4500	m

Heat dissipation

The heat is dissipated by conduction via the mounting surface. Thereby, it has to be absolutely observed not to exceed the maximum permissible temperature of 70°C (hot spot) – not even at maximum ambient temperature – at the mounting surface of the power supply.

To obtain a long service life and high reliability it is, however, advisable to keep the power supply temperature as far below its maximum value as possible.

As regards reliability, a thermally conductive connection between tube and power supply has to be avoided.

Response of the protective devices

The power supply unit is automatically cut off upon exceeding the maximum permissible helix load of the tube.

After the protective devices (used against helix overload) have responded, the turn-on procedure for the power supply is repeated 8 times. Only if the overload exists still after that, the final disconnection will be carried out.

A new check cycle is started by pressing the reset button. Every two hours an automatic reset command sets the error counter to zero.

If an automatic disconnection due to excess helix current or line failure lasts 5 seconds or less, the tube will be ready for operation immediately after the automatically repeated turn-on.

Should the failure or disconnection last longer than 5 seconds, a delay of grid 2 voltage becomes effective.

Pins at high-voltage side

		Pin
+Heater/cathode	+ F/K	27
-Heater	- F	22
Grid 2	G2	47
Helix/ground	H/⊥	64/65
Collector 1	C1	51
Collector 2	C2	40
Interlock circuit		54-60

Pins at low-voltage side

Ground or Com: pin 8 The grounding pin connection to housing is electrically conductive. It is exclusively intended as reference potential for I_k and I_h measurement, not for grounding the unit.

U_B : +pins 7, 14 -pins 6, 13 Voltage supply (ungrounded).

Stby/Trm: +pin 4 -pin 12 At this input a dc voltage of 6 to 30 V switches the grid 2 voltage to the tube after the preheating period. The input is ungrounded and has an impedance of approx. 3.3 k Ω .

Reset: +pin 3 -pin 11 At this input a dc voltage of 6 to 30 V is shortly applied to set the error counter to zero and to turn on the power supply again after automatic disconnection. The input is ungrounded and has an impedance of 3.3 k Ω .

Aux.: pin 5 Positive output voltage with respect to $-U_B$, approx. 15 V to 25 V (R_i approx. 100 Ω) to operate functions Stby/Trm, Reset, Indic.

Indic.: +pin 2 -pin 10 An NPN transistor ($U_{CE\ max}$ 35 V/ $I_C\ max$ 100 mA) conducts (ungrounded - open collector) if:
a) the power supply is automatically checked for the last time,
b) the power supply has turned off completely,
c) the helix current exceeds 3 ± 0.3 mA.

I_k : pin 9 Pin to measure the cathode current with respect to ground. 1 V measuring voltage corresponds to a 10 mA cathode current with an external load of 100 k Ω (error max. ± 3 mA at $I_k = 100$ mA). The impedance of the measuring output is approx. 2.2 k Ω .

Control unit BT 300 has another calibration of the I_k measuring output. The manufacturer is responsible for adjusting the I_k measuring output in the power supply unit.

I_h : pin 1 Pin to measure the helix current with respect to ground. 1 V measuring voltage corresponds to 1 mA helix current (error max. ± 50 μ A at $I_h = 1$ mA with an external load of ≥ 100 k Ω). This measuring output can be switched to "1 V measuring voltage corr. to 0.5 mA helix current" by a coding switch. The impedance of the measuring output is 1 k Ω or 2 k Ω , respectively.

Circuit example for low-voltage connector

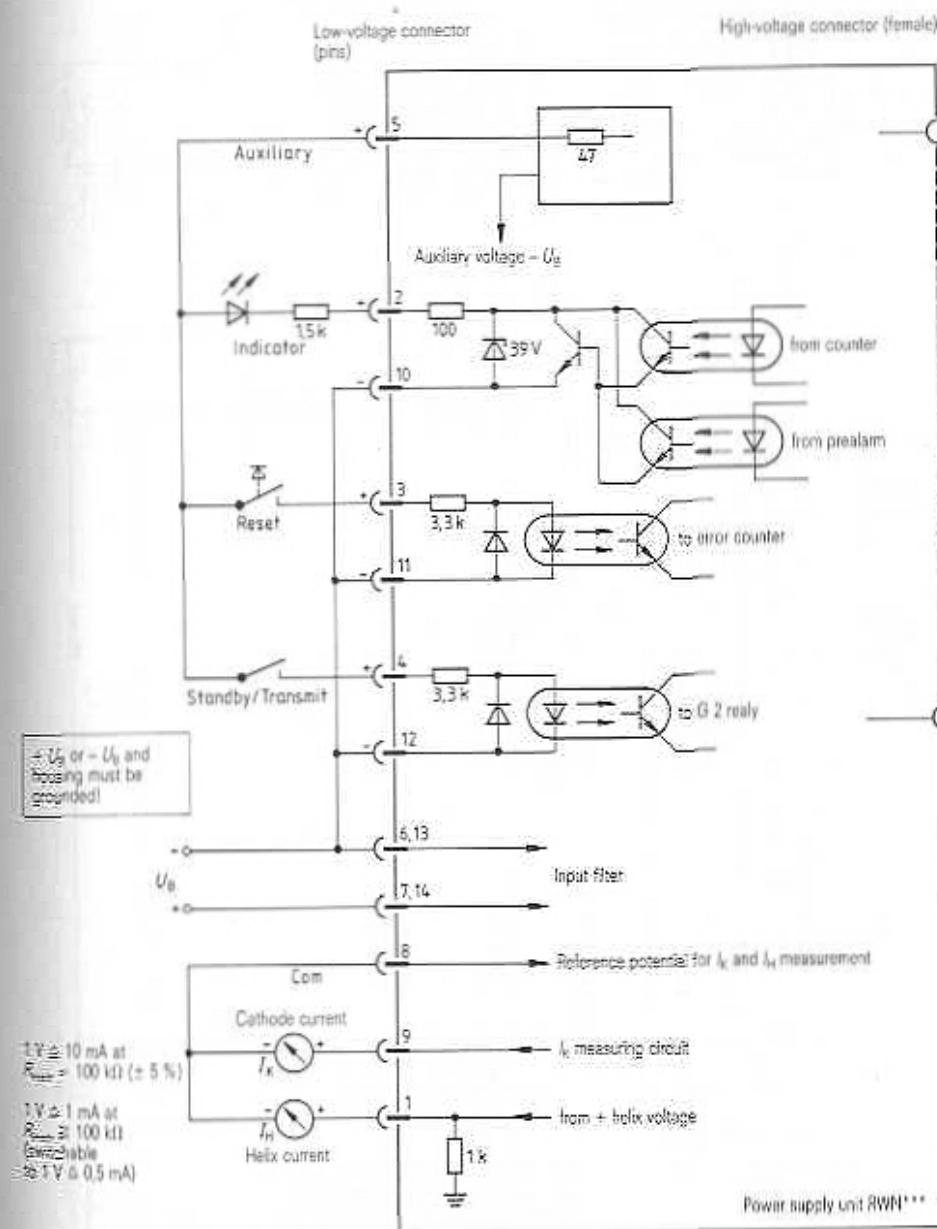

Outline drawing RWN 120.

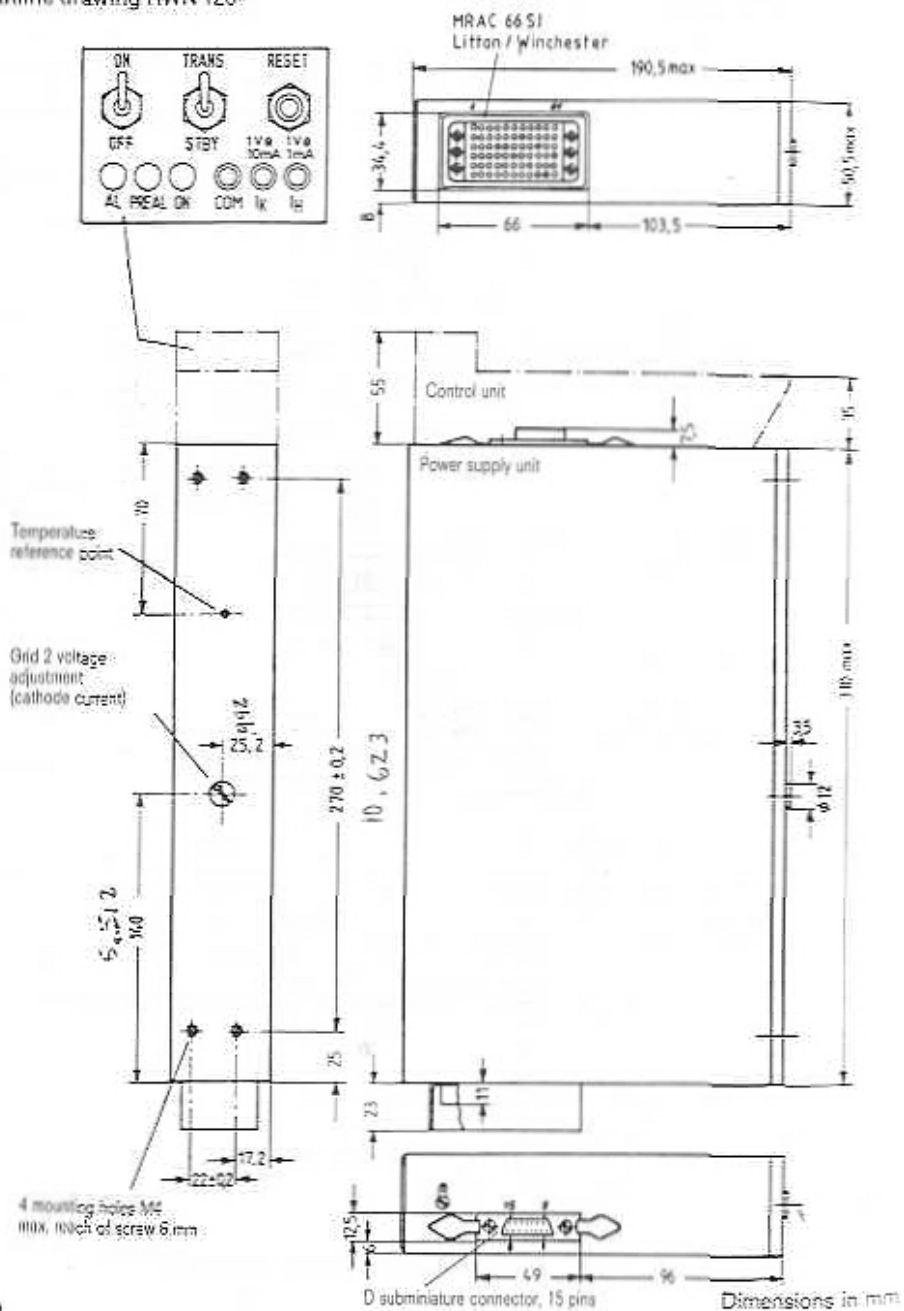

Outline drawing RWN 121

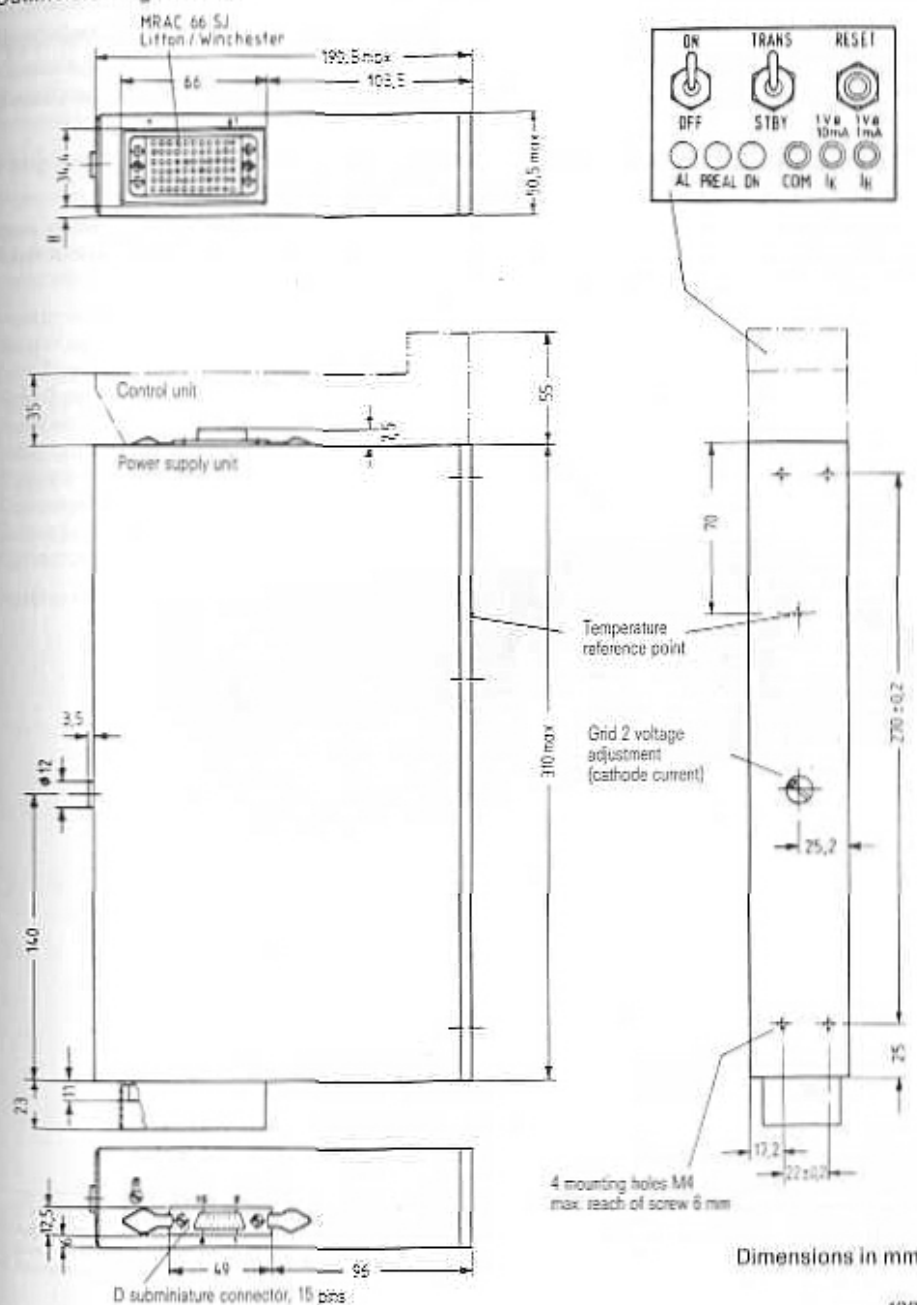

Power supply unit to operate radio link TWTs, such as RW 189 and RW 1136.

The unit is designed for a rated input voltage range between 24 V and 60 V (without switching), and includes all necessary safety, monitoring, and control functions.

The power supply can be adjusted to the individual tube operating voltages by internal switching.

The heat is dissipated by conduction via the mounting surface. With RWN 220 the grid 2 voltage is adjusted at the mounting side, with RWN 221 at the opposite side.

A plug-in control unit is additionally available, comprising power switch, standby switch, reset button, alarm and prealarm indicators, as well as outputs for remote prealarm, remote reset, cathode and helix current measurement.



Power supply unit RWN 220
Power supply unit RWN 221

Weight
Dimensions of power supply
Dimensions of packing
Low-voltage connector
High-voltage connector (female)
Mounting position

Ordering code Q87-X349
Ordering code Q87-X323

approx. 2.8 kg net, approx. 4.3 kg gross
approx. 340 mm × 50 mm × 190 mm
approx. 550 mm × 160 mm × 310 mm
D subminiature connector, 15 pins
MRAC 66SJ, Litton/Winchester
any

Characteristics, input

Rated voltage range	U_B	24 ... 60	V dc
Operating voltage range	U_E	20 ... 75	V dc
Power consumption	P_E	max 120	W
Internal input protection (pico fuse)		15	A

The input is ungrounded. Plus or minus U_E , and power supply housing have to be grounded.

Warning! Turning on without grounding destroys the device.

Characteristics, outputs

(operating voltages for the tube)

Heater voltage	U_H	6.3 ± 0.2	V
Heater current	I_H	0.5 ... 0.6	A
Grid 2 voltage	U_{G2}	900 ... 2900	V ¹⁾
Grid 2 current	I_{G2}	-0.1 ... +0.5	mA
Helix voltage	U_H	2150 ... 3250	V ²⁾
Helix current	I_H	max 4	mA
Collector 1 voltage	U_{C1}	1350/1450/1600/1700	V ³⁾
Collector 1 current	I_{C1}	max 40	mA ⁴⁾
Collector 2 voltage	U_{C2}	360/400/430/450	V ³⁾
Collector 2 current	I_{C2}	max 140	mA ⁴⁾

A defective tube does not impair the power supply unit.

¹⁾ Continuously adjustable at the front panel (within sub-range steps that can be set according to tube type inside the device).
²⁾ Adjustable inside the device in steps of 50 V.
³⁾ Can be set inside the device.
⁴⁾ The sum of collector 1 current and collector 2 current may not exceed 140 mA.

Environmental conditions

Operating temperature at front panel
(see temperature reference point)

Continuous operation	0 ... 70	°C
Temporarily for max. 8 h and for max. 96 h annually	max 75 min -20	°C
Turn-on temperature	-40 ... +75	°C
Storage temperature	max 95	°C
Relative humidity (during operation)	(no dew precipitation)	%
Application altitude	max 4500	m

Heat dissipation

The heat is dissipated by conduction via the mounting surface. Thereby, it has to be absolutely observed not to exceed the maximum permissible temperature of 70°C (hot spot) – not even at maximum ambient temperature – at the mounting surface of the power supply.

To obtain a long service life and high reliability it is, however, advisable to keep the power supply temperature as far below its maximum value as possible.

As regards reliability, a thermally conductive connection between tube and power supply has to be avoided.

Response of the protective devices

The power supply unit is automatically cut off upon exceeding the maximum permissible helix load of the tube.

After the protective devices (used against helix overload) have responded, the turn-on procedure for the power supply is repeated 8 times. Only if the overload exists still after that, the final disconnection will be carried out.

A new check cycle is started by pressing the reset button. Every two hours an automatic reset command sets the error counter to zero.

If an automatic disconnection due to excess helix current or line failure lasts 5 seconds or less, the tube will be ready for operation immediately after the automatically repeated turn-on.

Should the failure or disconnection last longer than 5 seconds, a delay of grid 2 voltage becomes effective.

Pins at high-voltage side

		Pin
+Heater/cathode	+F/K	27
-Heater	-F	22
Grid 2	G2	47
Helix, ground	H/⊥	64/65
Collector 1	C1	51
Collector 2	C2	40
Interlock circuit		54-60
Temperature compensation		61

Pins at low-voltage side

- Ground or Com:** pin 8 The grounding pin connection to housing is electrically conductive. It is exclusively intended as reference potential for I_k and I_h measurement, not for grounding the unit.
- U_B :** Voltage supply (ungrounded)
+ pins 7, 14
- pins 6, 13
- Stby/Trm:** At this input a dc voltage of 6 to 30 V switches the grid 2 voltage to the tube after the preheating period. The input is ungrounded and has an impedance of approx. 3.3 k Ω .
+ pin 4
- pin 12
- Reset:** At this input a dc voltage of 6 to 30 V is shortly applied to set the error counter to zero and to turn on the power supply again after automatic disconnection. The input is ungrounded and has an impedance of 3.3 k Ω .
+ pin 3
- pin 11
- Aux.:** Positive output voltage with respect to $-U_B$, approx. 15 V to 25 V (R_i approx. 47 Ω) to operate functions Stby/Trm, Reset, Indic.
pin 5
- Indic.:** An NPN transistor ($U_{CE,max}$ 35 V/ $I_{C,max}$ 100 mA) conducts (ungrounded - open collector) if
+ pin 2
- pin 10
- the power supply is automatically checked for the last time,
 - the power supply has turned off completely,
 - the helix current exceeds 3 ± 0.3 mA.
- I_k :** Pin to measure the cathode current with respect to ground. 1 V measuring voltage corresponds to a 10 mA cathode current with an external load of 100 k Ω (error max. ± 3 mA at $I_k = 100$ mA). The impedance of the measuring output is approx. 2.2 k Ω . Control unit BT 300 has another calibration of the I_k measuring output. The manufacturer is responsible for adjusting the I_k measuring output in the power supply unit.
pin 9
- I_h :** Pin to measure the helix current with respect to ground. 1 V measuring voltage corresponds to 1 mA helix current with an external load of ≥ 100 k Ω . Due to the temperature compensation the indicated helix current value may be up to 0.2 mA too high. This measuring output can be switched to "1 V measuring voltage corr. to 0.5 mA helix current" by a coding switch. The impedance of the measuring output is 1 k Ω or 2 k Ω , respectively.
pin 1

Circuit example for low-voltage connector

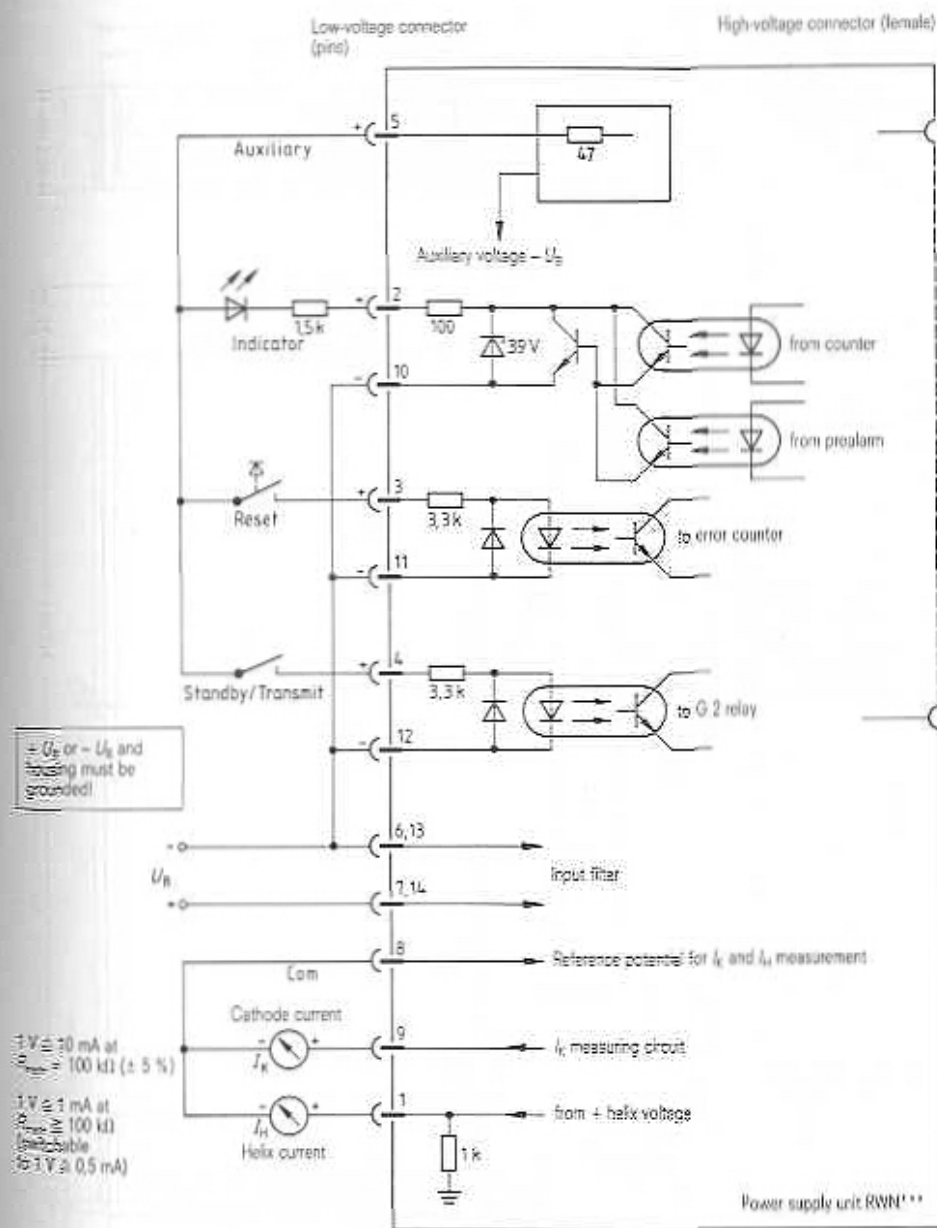

Outline drawing RWN 220

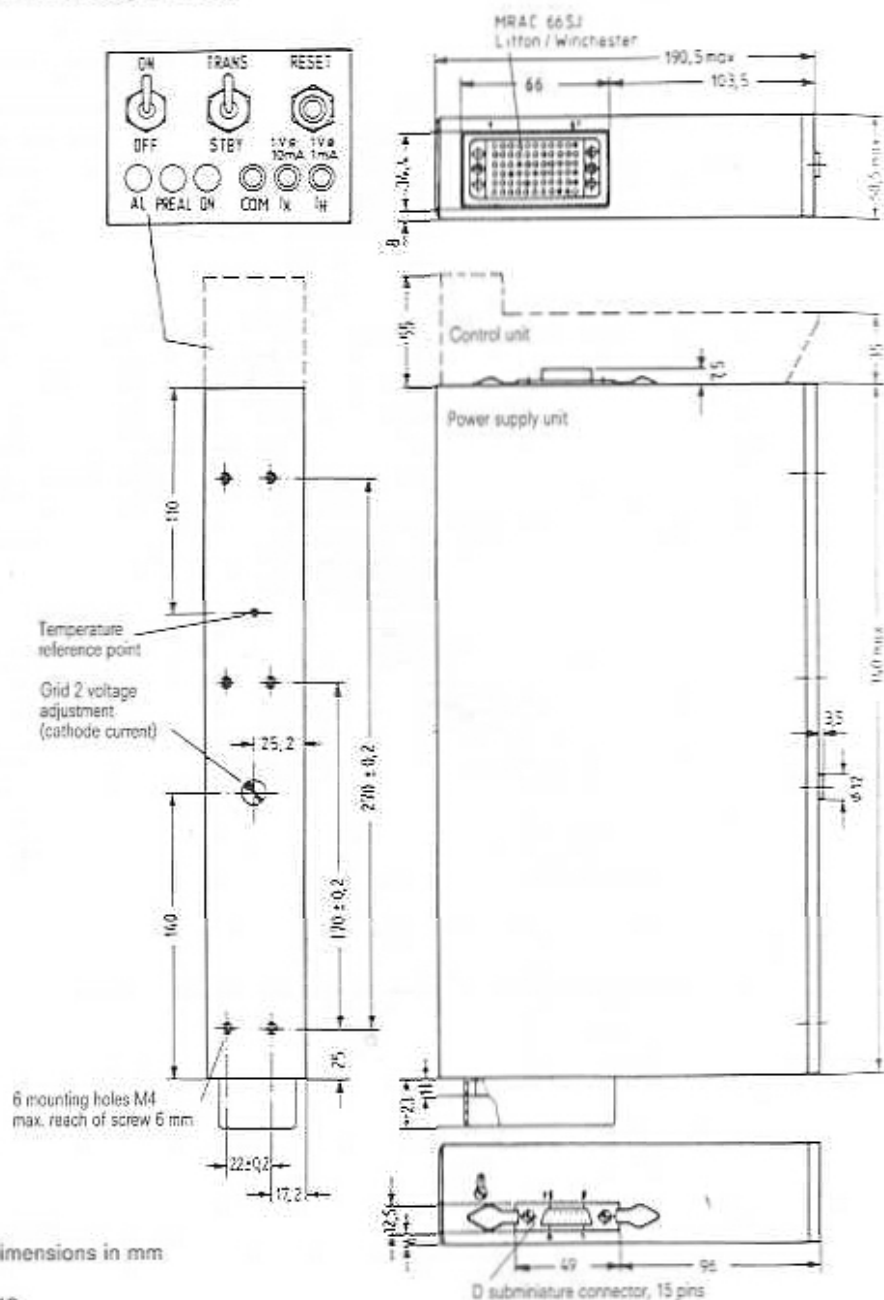

Outline drawing RWN 221

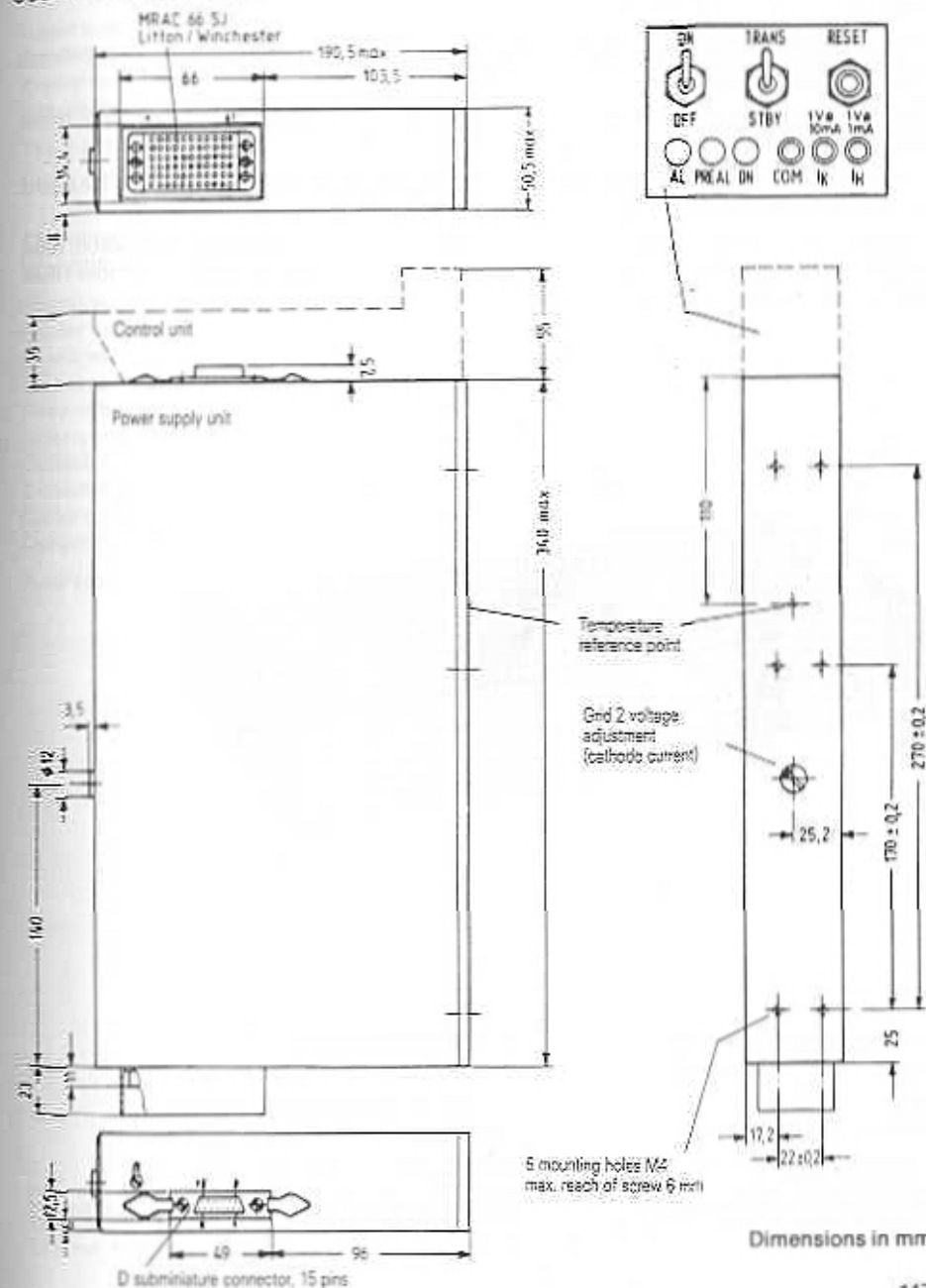

Power supply unit to operate radio link TWTs, such as RW 248, RW 289, RW 290, RW 1127, and RW 2135.

The unit is designed for a rated input voltage range between 24 V and 60 V (without switching), and includes all necessary safety, monitoring, and control functions.

The power supply can be adjusted to the individual tube operating voltages by internal switching.

The heat is dissipated by conduction via the mounting surface. With RWN 320 the grid 2 voltage is adjusted at the mounting side, with RWN 321 at the opposite side.

A plug-in control unit is additionally available, comprising power switch, standby switch, reset button, alarm and prealarm indicators, as well as outputs for remote prealarm, remote reset, cathode and helix current measurement.

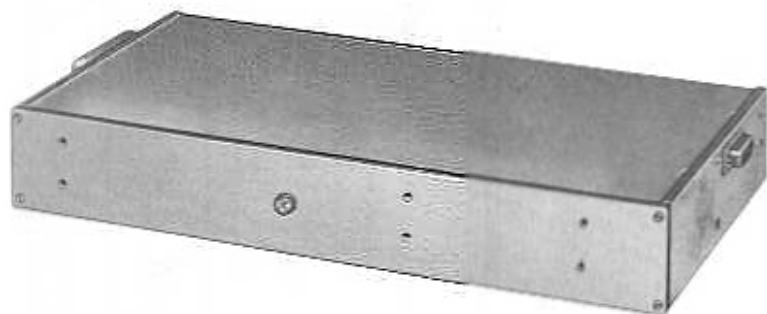

**Power supply unit RWN 320
Power supply unit RWN 321**

Weight
Dimensions of power supply
Dimensions of packing
Low-voltage connector
High-voltage connector (female)
Mounting position

**Ordering code Q87-X317
Ordering code Q87-X322**

approx. 2.8 kg net, approx. 4.3 kg gross
approx. 340 mm × 50 mm × 190 mm
approx. 550 mm × 160 mm × 310 mm
D subminiature connector, 15 pins
MFIAC 66SJ, Litton/Winchester
any

Characteristics, input

Rated voltage range	U_B	24 ... 60	V dc
Operating voltage range	U_B	20 ... 75	V dc
Power consumption	P_E	max 150	W
Internal input protection (pico fuse)		15	A

The input is ungrounded. Plus or minus U_B , and power supply housing have to be grounded.

Warning! Turning on without grounding destroys the device.

Characteristics, outputs

(operating voltages for the tube)

Heater voltage	U_F	6.3 ± 0.2	V
Heater current	I_F	0.5 ... 0.6	A
Grid 2 voltage	U_{G2}	2300 ... 4700	V ¹⁾
Grid 2 current	I_{G2}	-0.2 ... +0.5	mA
Helix voltage	U_H	3600 ... 5100	V ²⁾
Helix current	I_H	max 3	mA
Collector 1 voltage	U_{C1}	1600/1800/2000/2400	V ²⁾
Collector 1 current	I_{C1}	max 30	mA ³⁾
Collector 2 voltage	U_{C2}	270/300/330/400	V ²⁾
Collector 2 current	I_{C2}	max 140	mA ³⁾

A defective tube does not impair the power supply unit.

¹⁾ Continuously adjustable at the front panel (within sub-range steps that can be set according to tube type inside the device).
²⁾ Adjustable in steps inside the device.
³⁾ The sum of collector 1 current and collector 2 current may not exceed 140 mA.

Environmental conditions

Operating temperature at front panel (see temperature reference point)		
Continuous operation	0 ... 70	°C
Temporarily for max. 8 h and for max. 96 h annually	max 75	°C
Turn-on temperature	min -20	°C
Storage temperature	-40 ... +75	°C
Relative humidity (during operation)	max 95 (no dew precipitation)	%
Application altitude	max 4500	m

Heat dissipation

The heat is dissipated by conduction via the mounting surface. Thereby, it has to be absolutely observed not to exceed the maximum permissible temperature of 70°C (hot spot) – not even at maximum ambient temperature – at the mounting surface of the power supply.

To obtain a long service life and high reliability it is, however, advisable to keep the power supply temperature as far below its maximum value as possible.

As regards reliability, a thermally conductive connection between tube and power supply has to be avoided.

Response of the protective devices

The power supply unit is automatically cut off upon exceeding the maximum permissible helix load of the tube.

After the protective devices (used against helix overload) have responded, the turn-on procedure for the power supply is repeated 8 times. Only if the overload exists still after that, the final disconnection will be carried out.

A new check cycle is started by pressing the reset button. Every two hours an automatic reset command sets the error counter to zero.

If an automatic disconnection due to excess helix current or line failure lasts 5 seconds or less, the tube will be ready for operation immediately after the automatically repeated turn-on.

Should the failure or disconnection last longer than 5 seconds, a delay of grid 2 voltage becomes effective.

Pins at high-voltage side

		Pin
+Heater/cathode	+F/K	21
-Heater	-F	22
Grid 2	G2	38
Helix/ground	H/⊥	64/65
Collector 1	C1	51
Collector 2	C2	34
Interlock circuit		54-60
Temperature compensation		61

Pins at low-voltage side

Ground or Com: pin 8: The grounding pin connection to housing is electrically conducting. It is exclusively intended as reference potential for I_k and I_h measurement, **not** for grounding the unit.

U_B : Voltage supply (ungrounded)
+pins 7, 14
-pins 6, 13

Stby/Trm: At this input a dc voltage of 6 to 30 V switches the grid 2 voltage to the tube after the preheating period. The input is ungrounded and has an impedance of approx. 3.3 k Ω .
+pin 4
-pin 12

Reset: At this input a dc voltage of 6 to 30 V is shortly applied to set the error counter to zero and to turn on the power supply again after automatic disconnection. The input is ungrounded and has an impedance of 3.3 k Ω .
+pin 3
-pin 11

Aux.: Positive output voltage with respect to $-U_B$, approx. 15 V to 25 V (R, approx. 47 Ω) to operate functions Stby/Trm, Reset, Indic.
pin 5

Indic.: An NPN transistor ($U_{CE\ max} = 35\ V / I_{C\ max} = 100\ mA$) conducts (ungrounded - open collector) if
+pin 2
-pin 10

I_k : Pin to measure the cathode current with respect to ground. 1 V measuring voltage corresponds to a 10 mA cathode current with an external load of 100 k Ω (error max. $\pm 3\ mA$ at $I_k = 100\ mA$).
pin 9

The impedance of the measuring output is approx. 2.2 k Ω . Control unit BT 300 has another calibration of the I_k measuring output. The manufacturer is responsible for adjusting the I_k measuring output in the power supply unit.

I_h : Pin to measure the helix current with respect to ground. 1 V measuring voltage corresponds to 1 mA helix current with an external load of $\geq 100\ k\Omega$. Due to the temperature compensation the indicated helix current level may be up to 0.3 mA too high. The impedance of the measuring output is 1 k Ω .
pin 1

Circuit example for low-voltage connector

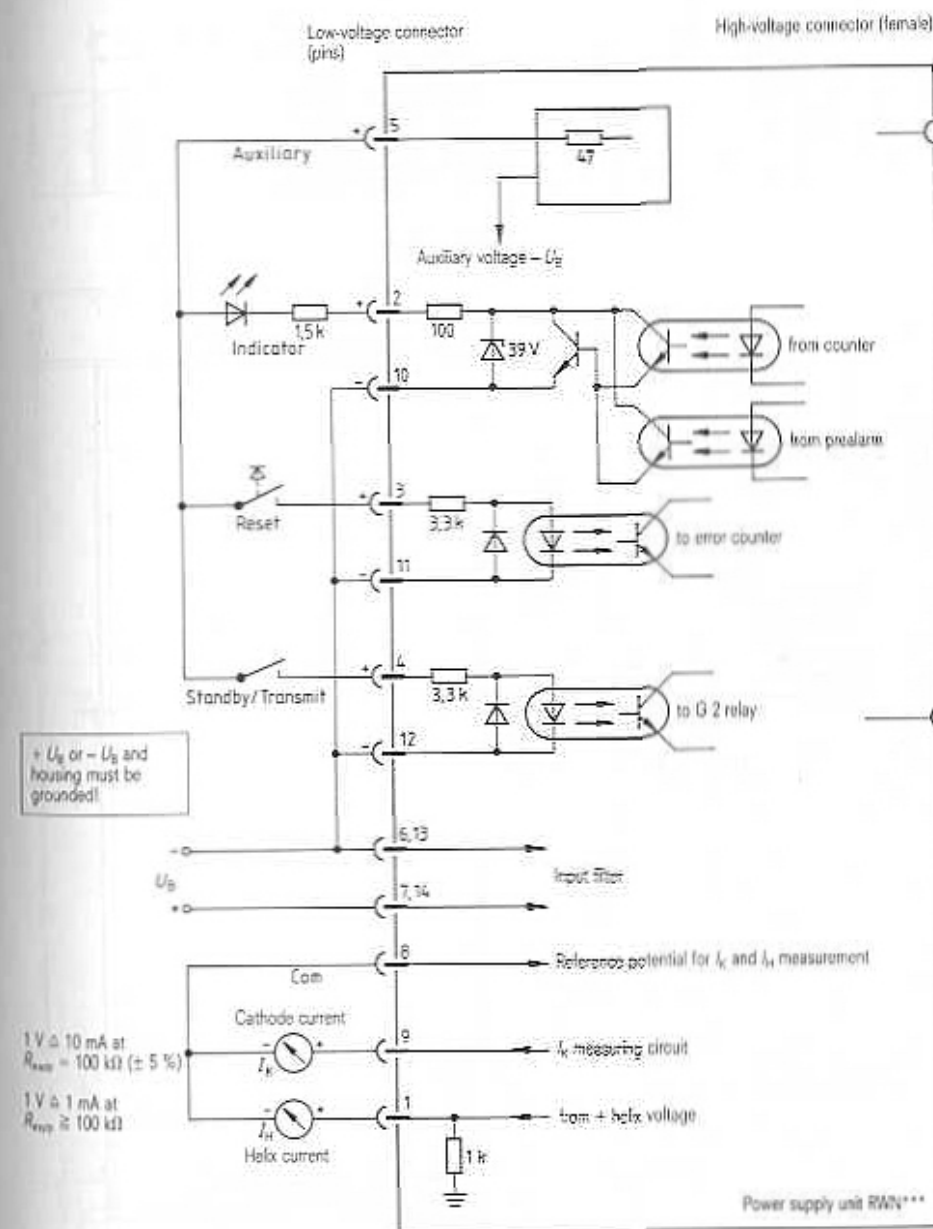

Outline drawing RWN 320

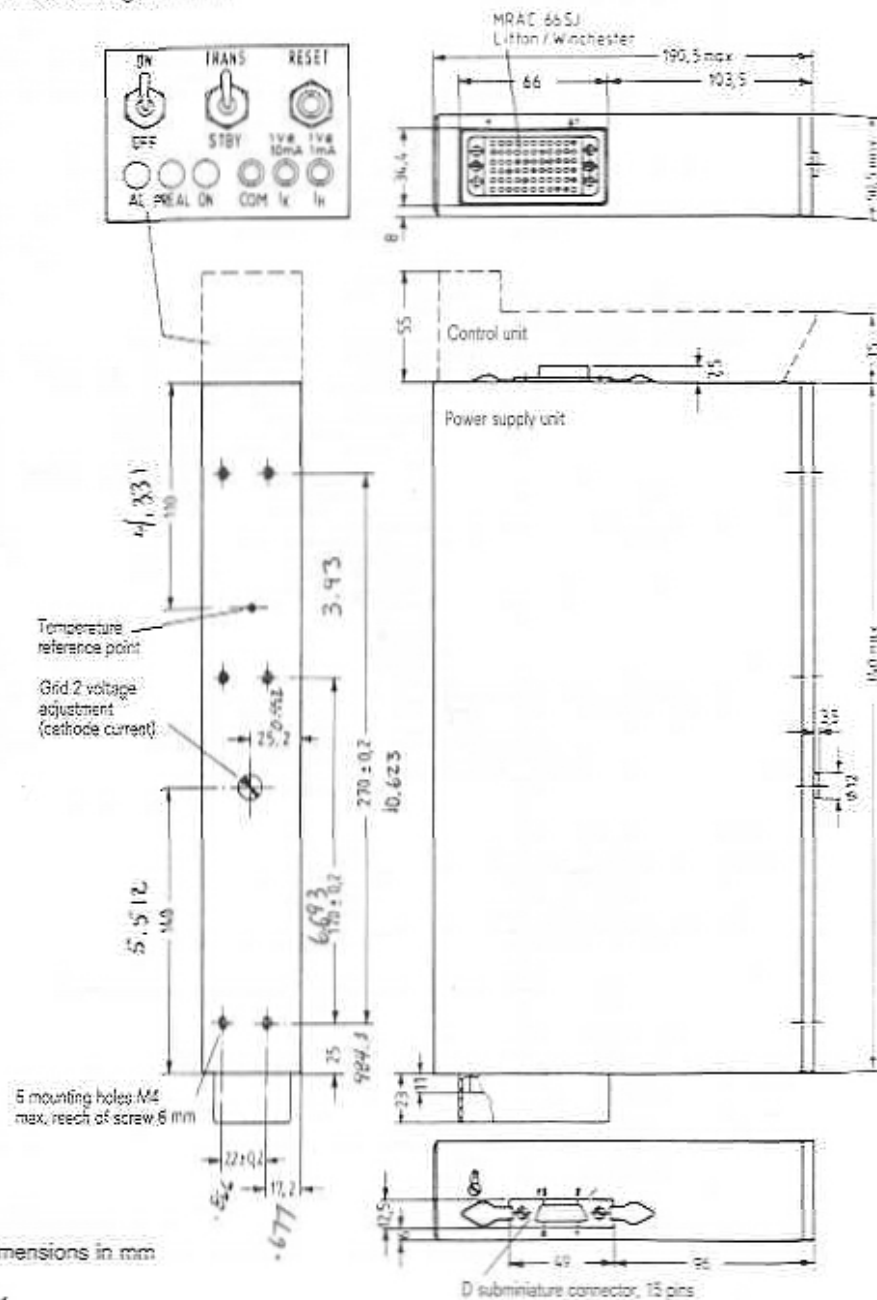

Dimensions in mm

Outline drawing RWN 321

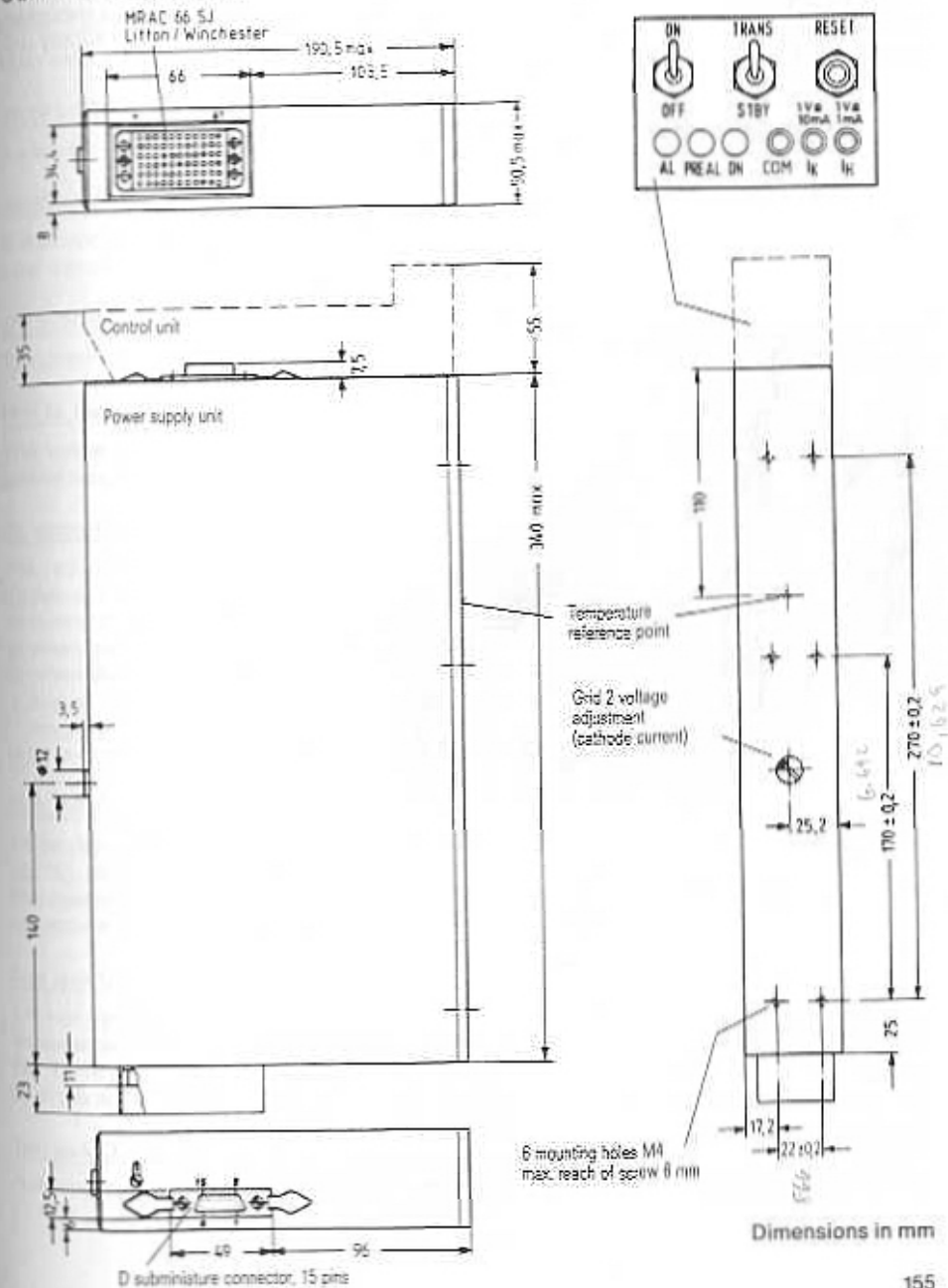

Dimensions in mm

Control unit BT 300 is suitable for TWT power supplies of the series RWN 1**, RWN 2** and RWN 3**: it contains all control elements, indicators, measuring and alarm outputs necessary for operating these power supply units. The control unit is plugged in the power supply unit and fixed by two clamps.



Control unit BT 300

Weight
Dimensions of the control unit
Dimensions of packing
Connectors to the
TWT power supply unit

Input connector

Ordering code Q87-X355

approx. 0.2 kg net, approx. 0.35 kg gross
approx. 50 mm × 55 mm × 180 mm
approx. 95 mm × 105 mm × 305 mm
2 D subminiature connectors, 15 pins,
connection optionally to power supply unit
for front or for rear mounting
MRAC 14 PJ, Litton/Winchester

Control elements, LED indicators and measuring outputs on front panel

ON/OFF power switch

Main switch for disconnecting the supply voltage.

TRANS/STBY switch

Switch for changing from standby to RF operation.

RESET button

Button for resetting the error counter in the power supply unit and for renewed turning on after disconnection.

ON indicator

The green LED lights up when a cathode current $\geq 20 \pm 5$ mA flows in the tube.

PREAL indicator

The yellow LED lights up when the helix current reaches the prealarm threshold set in the power supply unit or when the last automatic switch-on cycle is initiated.

AL indicator

The red LED lights up

- a) during the preheating period
- b) during standby operation
- c) when the cathode current falls below 20 ± 5 mA
- d) when the power supply is cut off for helix overload or after 8 short disconnections of the supply voltage within 2 hours (the error counter registers short disconnections of the supply voltage).

In case d) the yellow LED PREAL also lights up.

Test jack for I_k (+)

1 V test voltage corresponds to 10 mA cathode current at an external load resistance of 100 k Ω (± 5 %). Impedance of the measuring output is approx. 2.2 k Ω .

The control unit BT 300 has another calibration of the I_k measuring output. The manufacturer is responsible for adjusting the I_k output in the power supply unit.

Test jack for I_H (+)

1 V test voltage corresponds to 1 mA helix current at an external load resistance ≥ 100 k Ω . Impedance of the measuring output is 1 k Ω .

For TWTs with temperature compensation the helix current indicated is up to 0.3 mA higher than the actual value.

Test jack COM and GND

Reference potential for I_k and I_H measurement, must not be used for grounding the device.

Pins of the input connector

Supply voltage U_s of the power supply unit
(pins D/F (-) and H/K (+, ground))

The supply voltage range is given in the data sheet on the power supply unit. It should be regarded that the lower rating becomes up to 1 V higher due to the voltage drop in the control unit.

Warning! $+U_s$ is connected to the housing.

The power supply unit must be properly grounded before it is turned on. Turning on without grounding destroys the device.

I_k and I_a measuring outputs

(pins B, M, N)

These outputs are parallel to the corresponding test jacks on the front panel.

Remote reset

(pins A and C)

These pins are intended for the remote actuation of the reset command (same function as reset button on front panel).

Alarm outputs

(pins E and J)

Depending on the operating condition pins E or J are connected through to ground by the switching contact of a monostable relay (contact data: max. 1 A/20 VA/100 V):

- a) During normal operation (LED ON lights up) the alarm relay is excited and pin E connected through to ground, while pin J is not connected.
- b) In case of alarm (LED AL lights up) the relay drops. Now pin E is not connected and pin J is connected to ground.

Prealarm outputs

(pins P and R)

Depending on the operating condition pins P or R are connected through to ground by the switching contact of a monostable relay (contact data: max. 1 A/20 VA/100 V):

- a) During normal operation (LED PREAL does not light up) the prealarm relay is excited and pin P connected through to ground while pin R is not connected.
- b) In case of prealarm (LED PREAL lights up) the relay drops. Now pin P is not connected and pin R is connected to ground.

Pin configuration

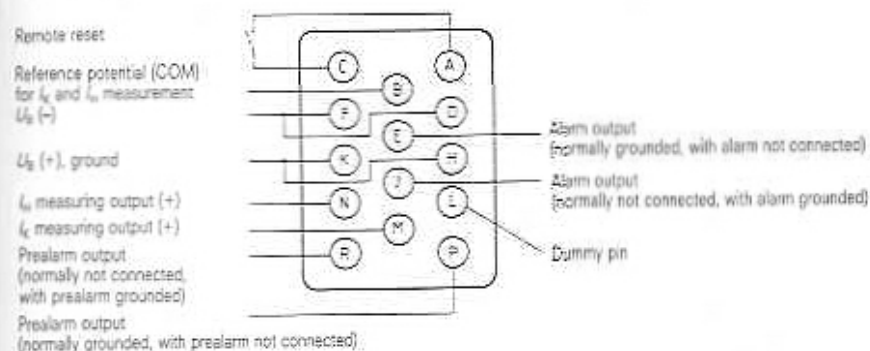

Outline drawing BT 300

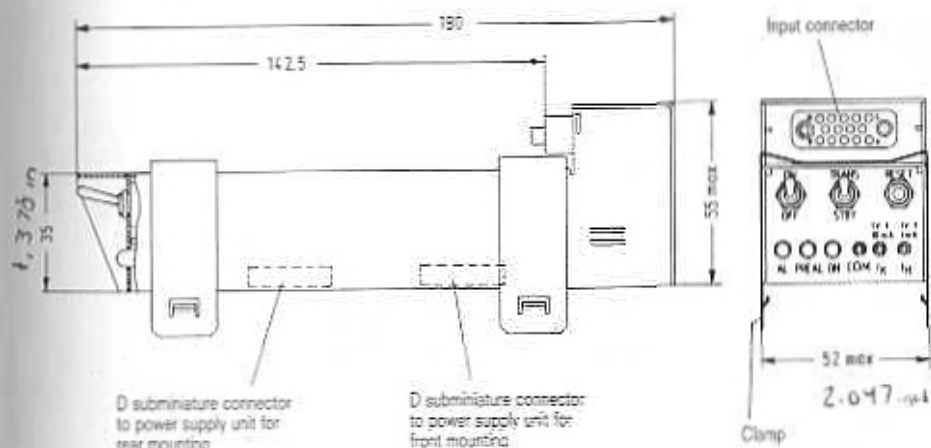

Dimensions in mm

**High Power TWTs
for Satellite Earth Stations,
TV and Troposcatter Transmitters**

For replacement only

Forced-air cooled power TWT for the frequency band 470 to 860 MHz, supplying a video synchronous output power of 160 W (band IV) or 200 W (band V). YH 1010 is particularly suitable for preamplifiers and TV frequency converters with combined vision and sound transmission.

The tube is provided with PPM focusing and can be replaced in the magnet system.

The RF power is coupled in and out by way of coaxial connectors.



Traveling wave tube YH 1010

Tube base
Weight of tube
Weight of magnet system
Dimensions of magnet system
Dimensions of tube packing
Dimensions of magnet system packing
RF connector
Mounting position

Ordering code Q42-X4610

special 8 pin type
approx. 2.7 kg net, approx. 6.5 kg gross
approx. 37.5 kg net, approx. 85 kg gross
approx. 195 mm × 220 mm × 750 mm
approx. 430 mm × 430 mm × 1050 mm
approx. 490 mm × 620 mm × 1250 mm
coaxial connector, 80 Ω
in stationary equipment: any. When mounted vertically, the best position with respect to cooling is with the collector up.

Heating

Heater voltage	U_F	6.3 (±2%)	V ¹⁾
Heater current	I_F	≈ 2.6	A

indirectly heated by dc (+ pole to cathode), supplied in parallel metal capillary dispenser cathode

Characteristics ($f = 700$ MHz, $I_K = 1.0$ A)

		min	nom	max	
Saturation power	P_{SAT}	450	550		W ²⁾
Power gain ($P_2 = 200$ W)	V_G	32	34		dB
VSWR	s		1.35	1.85	³⁾
Cold attenuation	α		70		dB

Operating characteristics for TV translators with combined vision and sound transmission

	f	470	700	MHz
Video sync. output power	P_{ZSY}	160	200	W
Vision/sound ratio		10:1	10:1	
Power gain	V_G	≥ 29	≥ 32	dB
3-tone intermodulation ratio	S_{IM3}	≥ 40	≥ 40	dB ⁴⁾
Collector voltage	U_C	$U_C - (350 ± 50)$	$U_C - (350 ± 50)$	V ⁵⁾
Helix voltage	U_H	≈ 3650	≈ 3350	V ⁶⁾
Grid 2 voltage	U_{G2}	≈ 850	≈ 1050	V
Grid 1 voltage, negative	$-U_{G1}$	100	100	V
Retarding electrode voltage	U_{RE1}	0	0	V ⁷⁾
Helix current	I_H	≈ 5	≈ 5	mA
Grid 2 current	I_{G2}	≤ ±0.5	≤ ±0.5	mA
Cathode current	I_K	1.0 (±2%)	1.0 (±2%)	A

- ¹⁾ The voltage drop in the cable has to be taken into account for an exact setting of the heater voltage at the tube connector. The voltage drop of the heater supply leads of the standard cable, supplied as an accessory, is 0.1 V/m.
²⁾ If the maximum deviation of the heater voltage exceeds the absolute limits of ±2%, the operating performance of the tube will be impaired and its life shortened. For standby operation (without applied electrode voltages), the heater voltage must be reduced to 5.6 V. The tube can be operated with full output power immediately after the heater voltage has been increased to its nominal value and the electrode voltages have been applied simultaneously.
³⁾ The saturation power may only be measured in pulsed operation.
⁴⁾ At input and output of the cold tube in the frequency band 470 to 860 MHz.
⁵⁾ $S_{IM3} ≥ 56$ dB is achieved by means of phase compensation.
⁶⁾ Measured with undistorted input signal in accordance with the specification: FTZ 176 Pt 2 of the German Post Office. Carrier levels: $F_{VISION} = -8$ dB; $F_{SOUND} = -16$ dB; $F_{MULTI} = -10$ dB.
⁷⁾ A protection resistor of 50 to 100 Ω is required in the cathode lead.
⁸⁾ The helix voltage can be adjusted to achieve optimum RF linearity (see diagram 5, versus f).
⁹⁾ The retarding electrode should be connected to the cathode via a resistor of 1 MΩ (10 W/4 kV).

Maximum ratings (absolute values)

Collector voltage	U_C	max	3500	V ¹⁾²⁾
Cold dc collector voltage	U_{C0}	max	4000	V
Collector dissipation	P_C	max	3600	W
Helix voltage	U_H	max	3800	V
Cold helix voltage	U_{H0}	max	4000	V
Helix current	I_H	max	30	mA ²⁾
Grid 2 voltage	U_{G2}	max	1700	V
Grid 2 current	I_{G2}	max	± 1	mA
Grid 1 voltage, negative	$-U_{G1}$	min	50	V
Grid 1 voltage, negative	$-U_{G1}$	max	200	V
Retarding electrode voltage	U_{RET}	max	0	V ⁴⁾
Cathode current	I_K	max	1100	mA
Load reflection	P_{rH}	max	20	W
Collector temperature	t_C	max	200	°C ⁵⁾
Ambient temperature	t_{amb}	min	0	°C
Ambient temperature	t_{amb}	max	50	°C
Storage temperature for tube and magnet	t_{stg}	min	-50	°C
Storage temperature for tube and magnet	t_{stg}	max	65	°C

1) The collector voltage must be 350 ± 50 V lower than the helix voltage.
 2) A protection resistor of 50 to 100 Ω is required in the cathode lead.
 3) Trip level for helix overcurrent protection circuit.
 4) The retarding electrode should be connected to the cathode via a resistor of 1 M Ω (10 W/4 kV).
 5) See cooling requirements.

General operating instructions

The TWT YH 1010 can only be operated in its magnet system MYH 1010.

For operating instructions and detailed data refer to performance specifications.

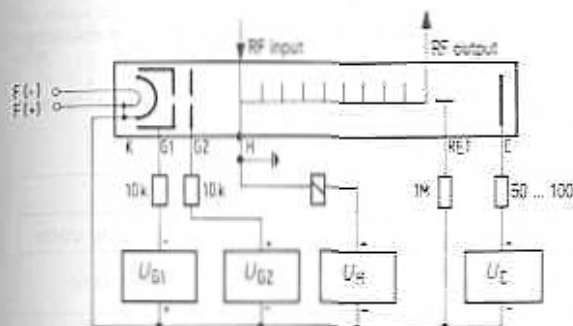

High voltage connections

supply cable attached to the tube base

Shielding of the supply cable (ground): black

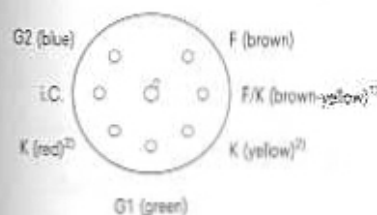

7) The cathode is internally connected to the heater (+pole).
 7) Connect red and yellow leads.

individual leads attached to the magnet system

C	yellow
RET	red
H, ground	ground terminal on magnet system

Cooling

The required air flow rate for cooling the collector for operation at mean sea level is shown in the pertinent diagram. The pressure drop in the air inlet and air outlet has not been considered.

The magnet system is designed such that the air inlet is from side A (side at which the magnet system is mounted). The air outlet is at side C.

If the cooling system fails, the tube supply voltages including heater voltage must be switched off automatically.

The cooling circuit must be designed such that the absolute maximum admissible collector temperature of 200°C is not exceeded.

The collector temperature is measured with a thermocouple at the surface of the two outer and one center cooling fins at the air outlet side (attention: collector voltage is applied).

Accessories

Designation	Design	Ordering code
Magnet system MYH 1010		Q43-X2410
Coaxial connector ¹⁾ (for RF input)	N connector	Q81-X2405
Coaxial connector ²⁾ (for RF output)	7/16	Q81-X2404
Connector YHZ 9461	bent in direction A cable length 2.5 m	Q81-X2341

¹⁾ The RF connectors should be ordered separately and can be reused when the tube is replaced.

Magnet system MYH 1010

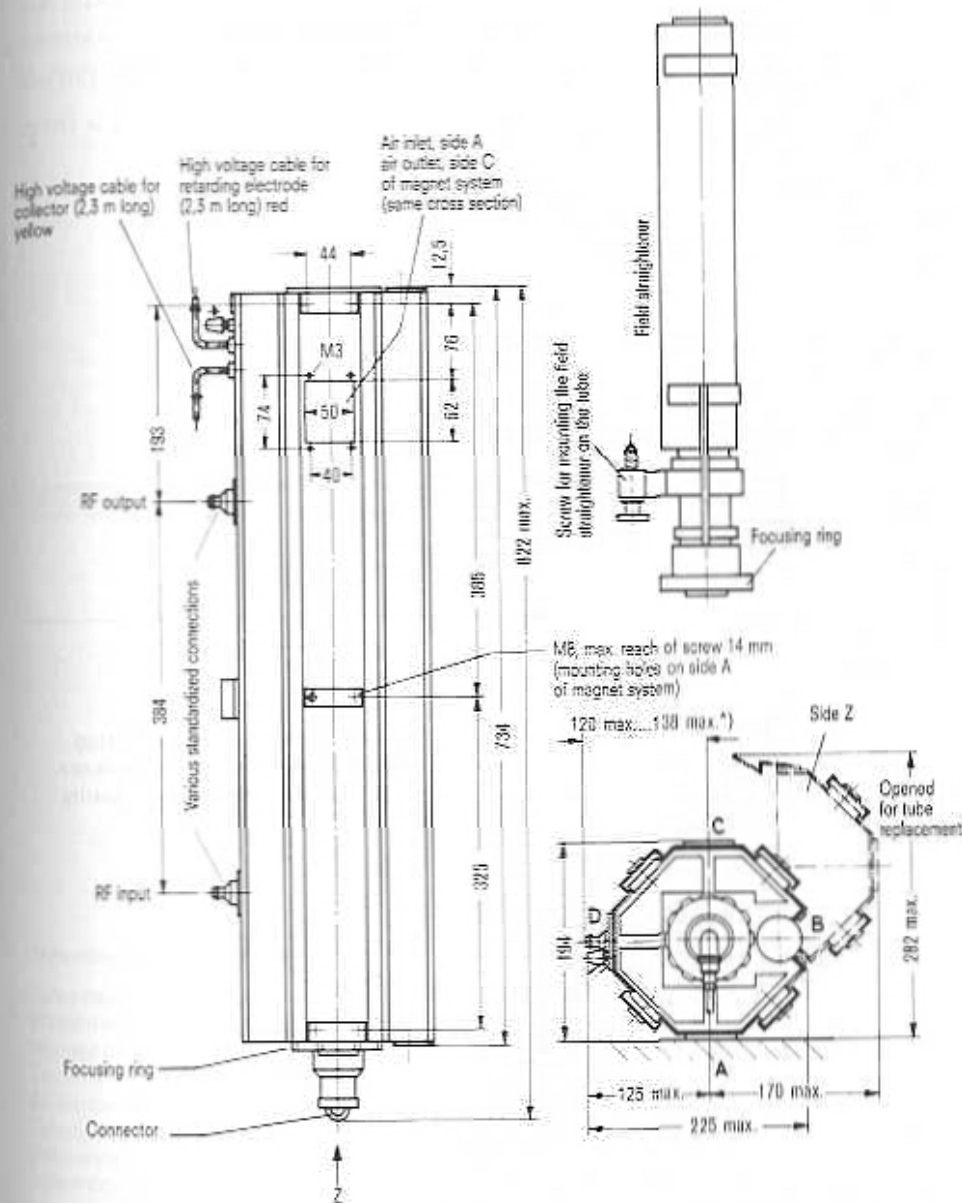

^{*)} according to coaxial connector

Dimensions in mm

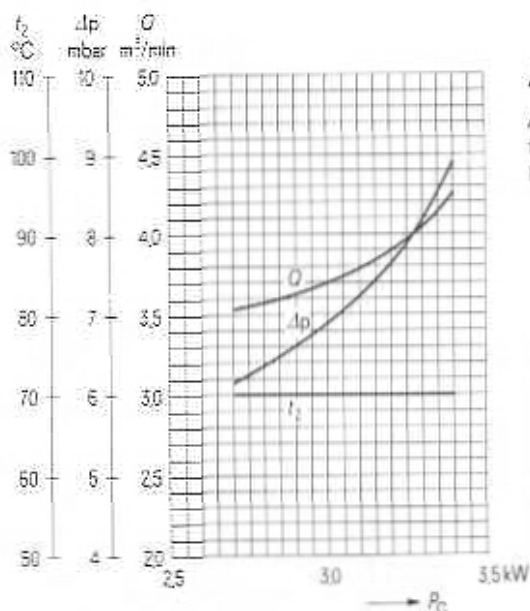

Air cooling diagram:

Air inlet temperature $t_1 = 25^\circ\text{C}$
for operation at mean sea level
Maximum radiator temperature = 170°C

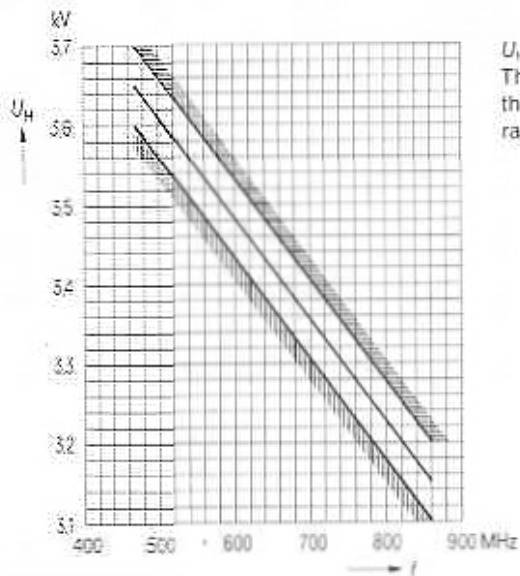

$U_H = f(f)$
The helix voltage can be readjusted
throughout the permissible tolerance
range to obtain optimum RF linearity.

For replacement only

Forced-air cooled power TWT for the frequency band 755 to 985 MHz. The tube supplies an output power of 800 W and is suitable for use in troposcatter systems.

YH 1014 is provided with PPM focusing and can be replaced in the magnet system.

The RF power is coupled in and out by way of coaxial connectors.



Traveling wave tube YH 1014

- Tube base
- Weight of tube
- Weight of magnet system
- Dimensions of magnet system
- Dimensions of tube packing
- Dimensions of magnet system packing
- RF connector
- Mounting position

Ordering code Q42-X4614

special 6 pin type
approx. 2.7 kg net, approx. 6.5 kg gross
approx. 37.5 kg net, approx. 85 kg gross
approx. 195 mm × 220 mm × 750 mm
approx. 430 mm × 430 mm × 1050 mm
approx. 490 mm × 620 mm × 1250 mm
coaxial connectors, 50 Ω
in stationary equipment: any. When mounted vertically: the best position with respect to cooling is with the collector up.

Heating

Heater voltage	U_F	6.3 ($\pm 2\%$)	V ¹⁾
Heater current	I_F	≈ 2.6	A
Preheating time	t_h	none	

indirectly heated by dc (+ pole to cathode), supplied in parallel metal capillary dispenser cathode

Characteristics ($f = 850$ MHz, $I_K \leq 950$ mA)	min	nom	max	
Output power	P_2	800		W
VSWR	s	1.35	1.85	²⁾
Cold attenuation	α	70		dB

Operating characteristics for use in troposcatter systems

Frequency band	f	755 ... 985	MHz ³⁾
Output power	P_2	800	W
Input power	P_1	1 ... 3.5	W
Collector voltage	U_C	$U_H - (280 \pm 40)$	V ⁴⁾
Helix voltage	U_H	3000 ... 3500	V
Grid 2 voltage	U_{G2}	400 ... 1600	V
Grid 1 voltage, negative	$-U_{G1}$	100	V
Retarding electrode voltage	U_{RET}	0	V ⁵⁾
Helix current	I_H	≤ 70	mA
Grid 2 current	I_{G2}	$\leq \pm 0.5$	mA
Cathode current	I_K	≤ 950	mA
Noise figure	NF	≤ 37	dB
AM/PM conversion	K_p	≈ 2	$\%(\text{dB}^{-1})$

¹⁾ The voltage drop in the cable has to be taken into account for an exact setting of the heater voltage at the tube connection. The voltage drop of the heater supply leads of the standard cable, supplied as an accessory, is 0.1 V/m.

If the maximum deviation of the heater voltage exceeds the absolute limits of $\pm 2\%$, the operating performance of the tube will be impaired and its life shortened. For standby operation (without applied electrode voltages), the heater voltage must be reduced to 6.6 V. The tube can be operated with full output power immediately after the heater voltage has been increased to its nominal value and the electrode voltages have been applied simultaneously.

²⁾ At input and output of the cold tube in the frequency band 755 to 985 MHz.

³⁾ A protection resistor of 50 Ω to 100 Ω is required in the cathode lead.

⁴⁾ The retarding electrode should be connected to the cathode via a resistor of 1 M Ω (10 W/4 kV).

⁵⁾ AM/PM conversion is the phase shift of the RF output signal, when changing the input power by 1 dB.

Maximum ratings (absolute values)

Collector voltage	U_C	max	3500	V ¹⁾ ²⁾
Cold collector voltage	U_{C0}	max	4000	V
Collector dissipation	P_C	max	3500	W
Helix voltage	U_H	max	3700	V
Cold helix voltage	U_{H0}	max	4000	V
Helix current	I_H	max	50	mA ³⁾
Grid 2 voltage	U_{G2}	max	2000	V
Grid 2 current	I_{G2}	max	± 1	mA
Grid 1 voltage, negative	$-U_{G1}$	min	50	V
Grid 1 voltage, negative	$-U_{G1}$	max	200	V
Retarding electrode voltage	U_{RET}	max	0	V ⁴⁾
Cathode current	I_K	max	1050	mA
Load VSWR	s_L	max	1.3	⁵⁾
Load reflection including harmonic and spurious emission	P_{rh}	max	30	W
Collector temperature	t_C	max	200	$^{\circ}\text{C}$ ⁶⁾
Ambient temperature	t_{amb}	min	0	$^{\circ}\text{C}$
Ambient temperature	t_{amb}	max	50	$^{\circ}\text{C}$
Storage temperature for tube and magnet	t_{stg}	min	-50	$^{\circ}\text{C}$
Storage temperature for tube and magnet	t_{stg}	max	65	$^{\circ}\text{C}$

¹⁾ The collector voltage must be 280 ± 40 V lower than the helix voltage.

²⁾ A protection resistor of 50 Ω to 100 Ω is required in the cathode lead.

³⁾ Trip level for helix overcurrent protection circuit.

⁴⁾ The retarding electrode should be connected to the cathode via a resistor of 1 M Ω (10 W/4 kV).

⁵⁾ 740 to 1000 MHz.

⁶⁾ See cooling requirements.

General operating instructions

The TWT YH 1014 can only be operated in its magnet system MYH 1014.
For operating instructions and detailed data refer to performance specifications.

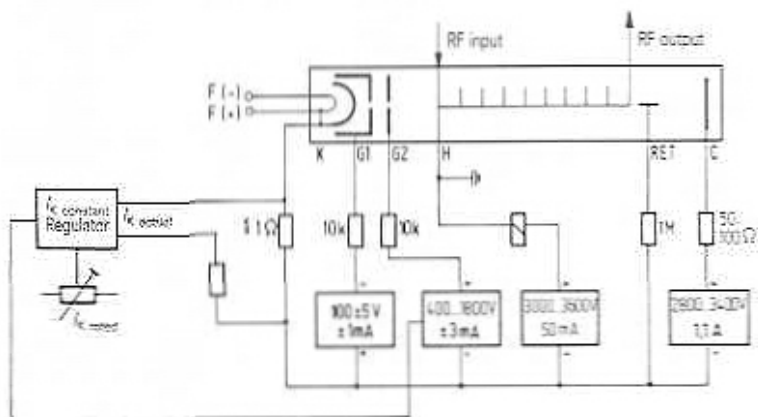

High voltage connections

supply cable attached to the tube base

Shielding of the supply cable (ground): black

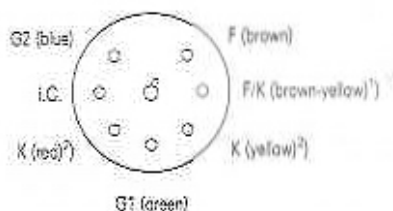

individual leads attached to the magnet system

- C yellow
- RET red
- H, ground ground terminal on magnet system

1) The cathode is internally connected to the heater (+ pole).
2) Connect red and yellow leads.

Cooling

The required air flow rate for cooling the collector for operation at mean sea level and 2000 m above mean sea level is shown in the pertinent diagram. The pressure drop in the air inlet and air outlet has not been considered.

The magnet system is designed such that the air inlet is from side A (side at which the magnet system is mounted). The air outlet is at side C.

If the cooling system fails, the tube supply voltages including heater voltage must be switched off automatically.

The cooling circuit must be designed such that the absolute maximum admissible collector temperature of 200°C is not exceeded.

The collector temperature is measured with a thermocouple at the surface of the two outer and one center cooling fins at the air outlet side (attention: collector voltage is applied).

Accessories

Designation	Design	Ordering code
Magnet system MYH 10 14		Q43-X4014
Coaxial connector ¹⁾ (for RF input)	N connector	Q81-X2405
Coaxial connector ¹⁾ (for RF output)	7/16	Q81-X2404
Connector YHZ 9461	bent in direction A cable length 2.5 m	Q81-X2341

¹⁾ The RF connectors should be ordered separately and can be reused when the tube is replaced.

Magnet system MYH 1014

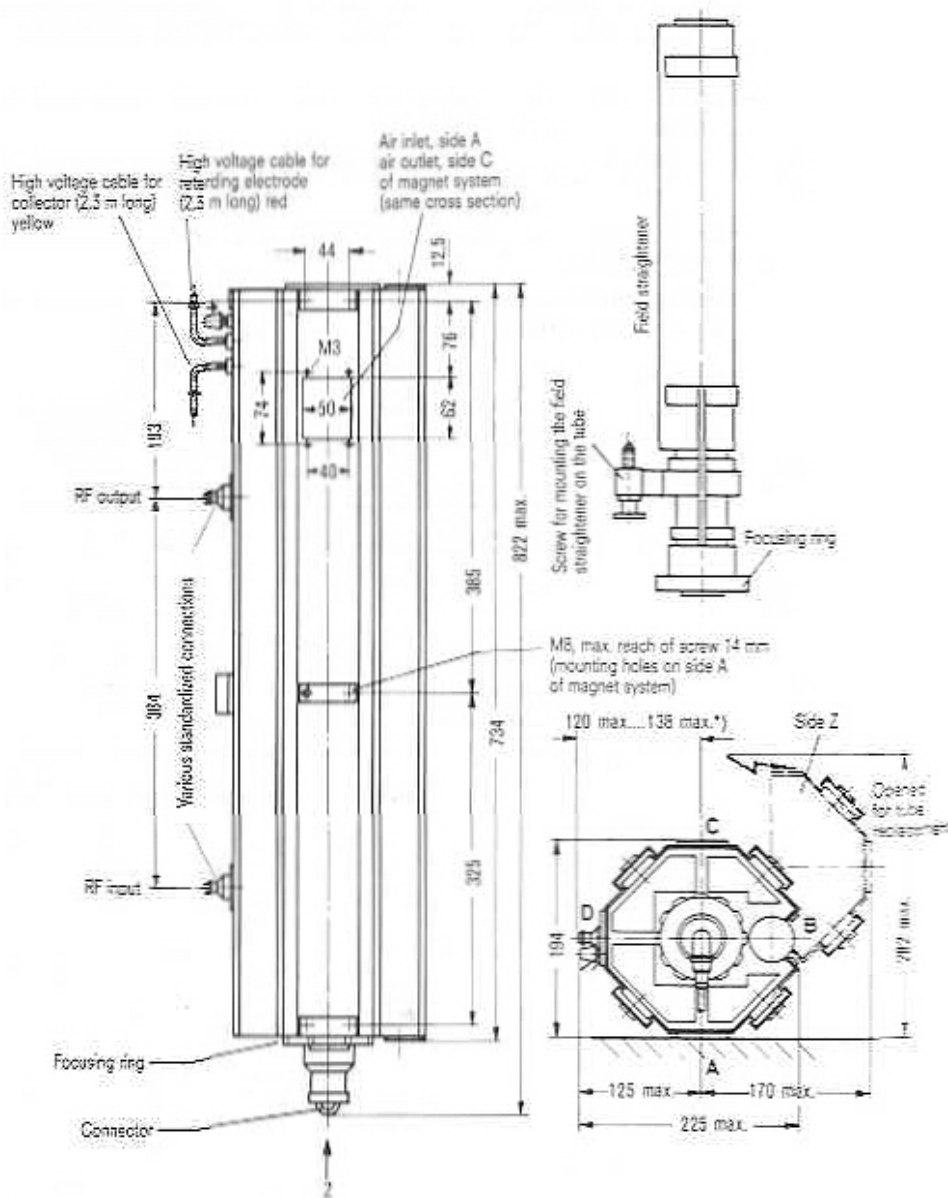

*) according to coaxial connector

Dimensions in mm

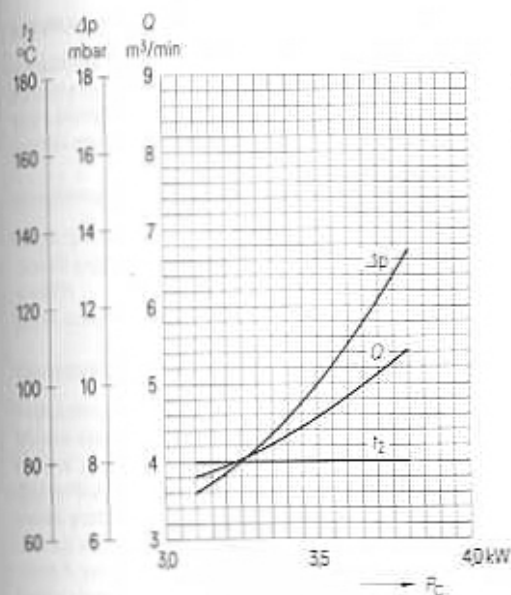

Air cooling diagrams

Air inlet temperature $t_1 = 25^\circ\text{C}$
 for operation at mean sea level
 Maximum radiator temperature = 170°C

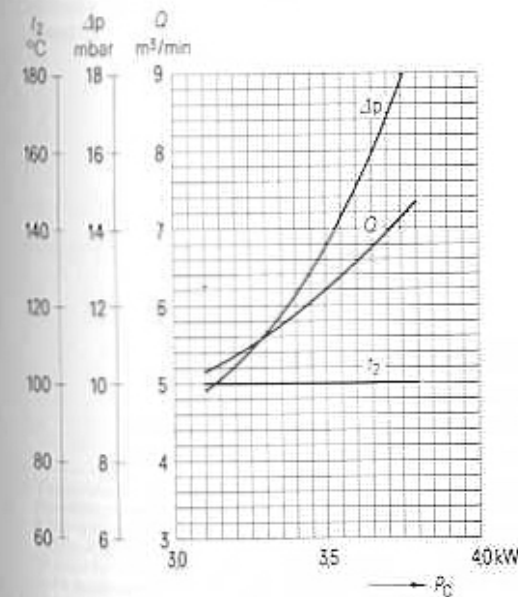

Air inlet temperature $t_1 = 45^\circ\text{C}$
 for operation at 2000 m
 above mean sea level
 Maximum radiator temperature = 170°C

For replacement only

Forced-air cooled power TWT for the frequency band 470 to 860 MHz, particularly suitable for preamplifiers and TV translators with a video synchronous output power to 50 W.

YH 1020 is provided with PPM focusing and can be replaced in the magnet system.

The RF power is coupled in and out by way of coaxial connectors.



Traveling wave tube YH 1020

Tube base
Weight of tube
Weight of magnet system
Dimensions of magnet system
Dimensions of tube packing
Dimensions of magnet system packing
RF connector
Mounting position

Ordering code Q42-X4651

special 8 pin type
approx. 2.5 kg net, approx. 6.2 kg gross
approx. 37.5 kg net, approx. 85 kg gross
approx. 200 mm × 220 mm × 750 mm
approx. 430 mm × 430 mm × 1050 mm
approx. 490 mm × 620 mm × 1250 mm
coaxial connector, 50 Ω
in stationary equipment: any. When mounted vertically: the best position with respect to cooling is with collector up.

Heating

Heater voltage	U_H	6.3 (±2%)	V ¹⁾
Heater current	I_H	= 2.6	A
Indirectly heated by ac metal capillary dispenser cathode			

Characteristics ($f = 700$ MHz, $I_K = 750$ mA)	min	nom	max	
Saturation power	P_{SAT}	350		W ²⁾
Small signal power gain	V_C	33	37	dB
VSWR	s		1.35	3)
Cold attenuation	α		70	dB

Operating characteristics for preamplifiers in TV transmitters

Frequency band	f	470 ... 790	MHz
Video synchronous output power	P_{25V}	50	W
Power gain	V_C	= 25	dB
Collector voltage	U_C	2600	V ⁴⁾
Helix voltage	U_H	2500	V
Grid 2 voltage	U_{G2}	0 ... 500	V
Grid 1 voltage, negative	$-U_{G1}$	100	V
Helix current	I_H	≤ 15	mA
Grid 2 current	I_{G2}	≤ ±0.5	mA
Cathode current	I_K	500	mA
Linearity		≥ 0.95	

¹⁾ The voltage drop in the cable has to be taken into account for an exact setting of the heater voltage at the tube connector. The voltage drop of the heater supply leads of the standard cable, supplied as an accessory, is 0.1 V/m. If the maximum deviation of the heater voltage exceeds the absolute limits of ±2%, the operating performance of the tube will be impaired and its life shortened. For standby operation (without applied electrode voltages), the heater voltage must be reduced to 5.6 V. The tube can be operated with full output power immediately after the heater voltage has been increased to its nominal value and the electrode voltages have been applied simultaneously.

²⁾ The saturation power may only be measured in pulsed operation.

³⁾ At input and output of the cold tube in the frequency band 470 to 860 MHz.

⁴⁾ The collector voltage must be 200 V lower than the helix voltage.

Maximum ratings (absolute values)

Collector voltage	U_C	max	3300	V ¹⁾
Cold collector voltage	U_{C0}	max	4000	V
Collector dissipation	P_C	max	2600	W
Helix voltage	U_H	max	3500	V
Cold helix voltage	U_{H0}	max	4000	V
Helix current	I_H	max	30	mA ²⁾
Grid 2 voltage	U_{G2}	max	1100	V
Grid 2 current	I_{G2}	max	± 3	mA
Grid 1 voltage: negative	$-U_{G1}$	max	200	V
Grid 1 voltage: positive	$+U_{G1}$	max	0	V
Cathode current	I_K	max	750	mA
Load reflection	P_m	max	20	W
Collector temperature	t_C	max	200	°C ³⁾
Ambient temperature	t_{amb}	min	-20	°C
Ambient temperature	t_{amb}	max	55	°C
Storage temperature for tube and magnet	t_{stg}	min	-50	°C
Storage temperature for tube and magnet	t_{stg}	max	65	°C

¹⁾ The collector voltage must be 200 V lower than the helix voltage.

²⁾ Trip level for helix overcurrent protection circuit.

³⁾ See cooling requirements.

General operating instructions

The TWT YH 1020 can only be operated in its magnet system MYH 1020.

For operating instructions and detailed data refer to performance specifications.

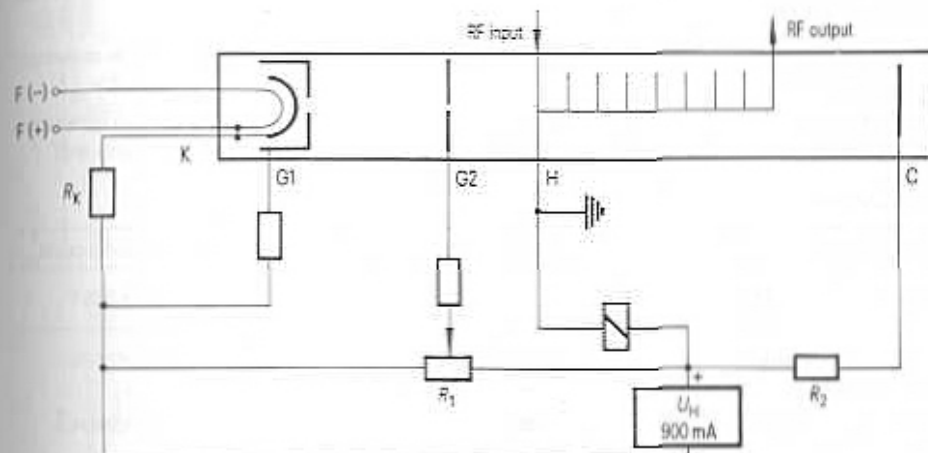

High voltage connections

supply cable attached to the tube base

Shielding of the supply cable (ground): black

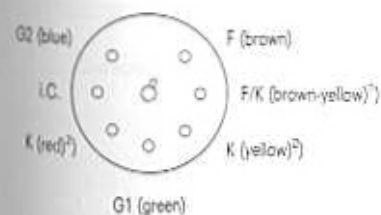

individual leads attached to the magnet system

C yellow
H, ground ground terminal on magnet system

¹⁾ The cathode is internally connected to the heater (+ pole).
²⁾ Connect red and yellow leads.

Cooling

The required air flow rate for cooling the collector for operation at mean sea level and 2500 m above mean sea level is shown in the pertinent diagram. The pressure drop in the air inlet and air outlet has not been considered.

The magnet system is designed such that the air inlet is from side A (side at which the magnet system is mounted). The air outlet is at side C.

If the cooling system fails, the tube supply voltages including heater voltage must be switched off automatically.

The cooling circuit must be designed such that the absolute maximum admissible collector temperature of 200 °C is not exceeded.

The collector temperature is measured with a thermocouple at the surface of the two outer and one of the center cooling fins at the air outlet side (attention: collector voltage is applied).

Accessories

Designation	Design	Ordering code
Magnet system MYH 1020		Q43-X2391
Coaxial connector ¹⁾ (for RF input)	N connector	Q81-X2405
Coaxial connector ¹⁾ (for RF output)	7/16	Q81-X2404
Connector YHZ 9481	bent in direction A cable length 2.5 m	Q81-X2341

¹⁾ The RF connectors should be ordered separately and can be reused when the tube is replaced.

Magnet system MYH 1020

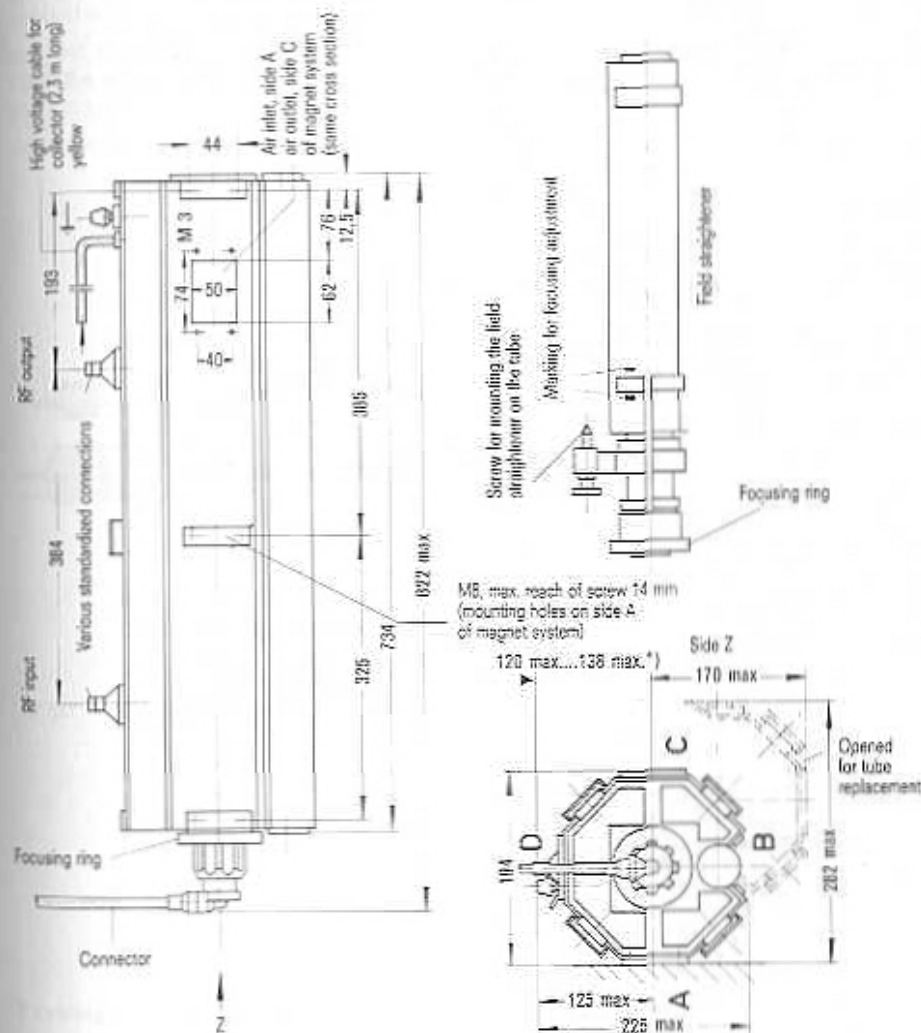

Dimensions in mm

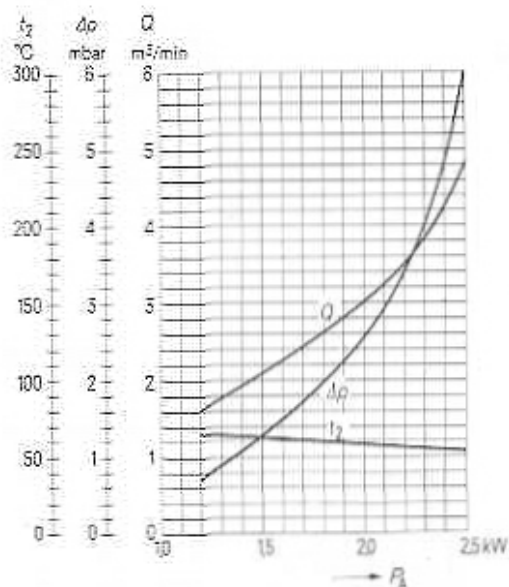
**Air cooling diagrams**

Air inlet temperature $t_1 = 25^\circ\text{C}$
 for operation at mean sea level
 Maximum radiator temperature = 170°C

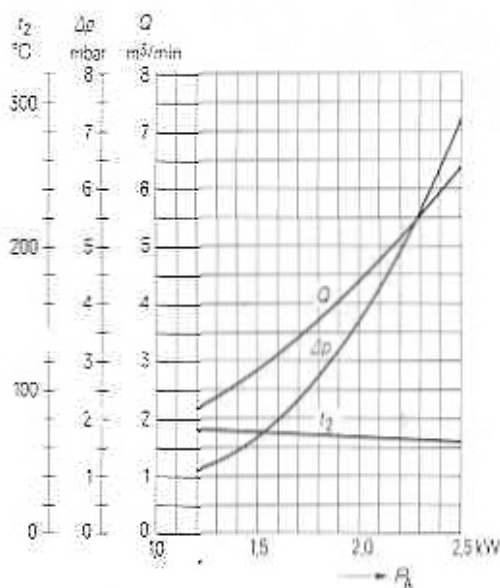

Air inlet temperature $t_1 = 35^\circ\text{C}$
 for operation at 2500 m
 above mean sea level
 Maximum radiator temperature = 185°C

For replacement only

High power TWT for satellite earth stations in the frequency band 5.925 to 6.425 GHz.

In single-carrier operation the tube supplies a continuous output power of 3 kW at a minimum gain of 29 dB. In dual-carrier operation with 500 W per carrier, the 3rd order intermodulation product is at least 24 dB.

YH 1041 is provided with PPM focusing and operates with depressed collector voltage. The tube is easily replaceable in the magnet system MYH 1041. The RF power is coupled in and out by way of waveguides.

Collector and delay line are water-cooled.

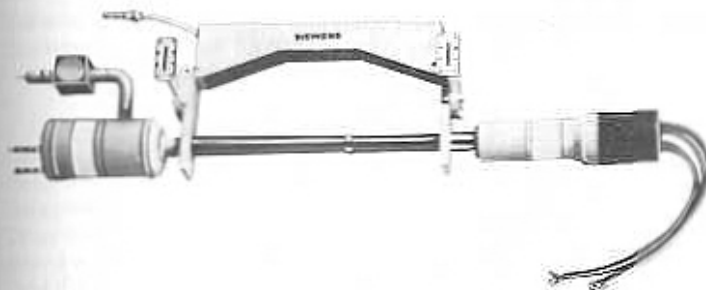
**Traveling wave tube YH 1041**

Weight of tube
 Length of tube
 Dimensions of tube packing
 Waveguide
 Flange
 Mounting position

Ordering code Q42-X4653

approx. 8.2 kg net, approx. 38 kg gross
 approx. 850 mm
 660 mm × 660 mm × 1520 mm
 F 70, DIN 47 302
 UGF 70, DIN 47 303
 vertically, collector down

Heating

Heater voltage	U_F	≈ 6.5	$V^{1) 2)}$
Preheating voltage	U_{PF}	$0.85 \times U_F$	V
Heater current	I_F	≈ 2.5	A
Preheating time	t_h	≥ 5	min

indirectly heated by ac or dc (+pole to cathode)
metal capillary cathode (MK cathode)

Characteristics ($f = 5.925 \dots 6.425$ GHz)		min	nom	max	
Power gain ($P_2 = 3$ kW)	V_p	29			dB
Gain slope ($P_2 = 2$ kW)	$\Delta V_p / \Delta f$		0.03		dB/(MHz ²)
VSWR	s		1.5	2.1	³⁾
Cold attenuation	a	60	80		dB
Harmonics up to 40 GHz		30			dB ⁴⁾

Operating characteristics for 3 kW CW single-carrier operation

Frequency band	f	5.925 ... 6.425	GHz
Output power	P_2	3	kW
Power gain	V_p	≥ 29	dB
Collector voltage	U_C	11	kV
Delay line voltage	U_H	16 ... 18	kV ¹⁾
Grid 2 voltage	U_{G2}	2.5 ... 4	kV ¹⁾
Grid 1 voltage, negative	$-U_{G1}$	80 ... 400	V ¹⁾
Collector current	I_C	1.2 ... 1.5	A ¹⁾
Delay line current	I_H	≤ 150	mA
Grid 2 current	I_{G2}	≤ 2	mA
AM/PM conversion	k_p	≤ 4.5	°/dB

¹⁾ The optimum setting value is indicated on the tube card, supplied with each tube.

²⁾ If the maximum deviation of the permissible heater voltage exceeds the actually set values by more than $\pm 2\%$, the operating performance of the tube will be impaired and its life shortened. For standby operation, the tube can be operated at 50% of the nominal heater voltage without the other electrode voltages applied.

The tube can be operated with full RF power immediately after the heater voltage has been increased to nominal value and the other electrode voltages are applied simultaneously.

³⁾ At input and output of the cold tube throughout the frequency band 5.925 to 6.425 GHz.

⁴⁾ Level of all harmonics below the fundamental in the frequency band 5.925 to 6.425 GHz.

⁵⁾ At a load VSWR ≤ 1.1 .

Operating characteristics for multi-carrier operation with two carriers each of 500 W, spaced 5 MHz apart

Frequency band	f	5.925 ... 6.425	GHz
Output power	P_2	1	kW
Power gain	V_p	≥ 31	dB
3rd order intermodulation product	d_3	≥ 24	dB
Collector voltage	U_C	11	kV
Delay line voltage	U_H	16 ... 18	kV ¹⁾
Grid 2 voltage	U_{G2}	2.4 ... 4	kV ¹⁾
Grid 1 voltage, negative	$-U_{G1}$	80 ... 400	V ¹⁾
Collector current	I_C	1.2 ... 1.5	A ¹⁾
Delay line current	I_H	≤ 150	mA
Grid 2 current	I_{G2}	≤ 2	mA

Maximum ratings (absolute values)

Collector voltage	U_C	max	14	kV
Collector voltage ($P_2 = 3$ kW)	U_C	min	11	kV
($\Sigma P_2 = 2$ kW)	U_C	min	10.5	kV
($\Sigma P_2 = 1$ kW)	U_C	min	7.5	kV
($\Sigma P_2 = 0.5$ kW)	U_C	min	5.5	kV
Collector dissipation	P_C	max	20	kW
Delay line voltage	U_H	max	18.5	kV
Delay line current without RF	I_{H0}	max	60	mA
Delay line current with RF	I_H	max	160	mA
Grid 2 voltage	U_{G2}	max	4.5	kV
Grid 2 dissipation	P_{G2}	max	9	W
Grid 1 voltage, negative	$-U_{G1}$	max	2.2	kV
Grid 1 voltage, negative	$-U_{G1}$	min	50	V
Cathode current	I_K	max	1.7	A
CW output power	P_2	max	3.5	kW
Load VSWR	s_L	max	1.2	²⁾
Ambient temperature	t_{amb}	min	-20	°C
Ambient temperature	t_{amb}	max	60	°C

¹⁾ The optimum setting value is indicated on the tube card, supplied with each tube.

²⁾ A circulator must be provided at the input and output of the tube. The load VSWR may not exceed 1.2:1 in the frequency band 5.925 to 6.425 GHz and 2:1 out of the band.

General operating instructions

The TWT YH 1041 can only be operated in conjunction with the magnet system MYH 1041.

When mounting the magnet system the distance between the magnet system and large ferromagnetic parts (e.g. mounting supports) should be 50 mm and between the magnet system and small ferromagnetic parts (e.g. screws) 10 mm. The spacing between two magnet systems should be at least 170 mm. In order to replace the tube, the magnet system can be swung open along its axis of symmetry.

Details on power supply such as electrical data, current and voltage monitoring etc., and operating instructions are contained in separate specifications.

Cooling

To dissipate the heat developed, the collector and the delay line must be cooled by deionized water.

Collector:

Water flow rate:	30	l/min
Pressure drop	4	bar
Inlet temperature	max 65	°C
Outlet temperature	max 85	°C

Delay line:

Water flow rate	4	l/min
Pressure drop	4	bar
Inlet temperature	max 65	°C
Outlet temperature	max 85	°C

The maximum permissible static pressure in cooling lines must not exceed 6 bar.

In view of the voltage difference between collector and delay line, it must be ensured that the water supply lines are appropriately insulated. The tube must be protected such that the supply voltages are disconnected from tube if there is a failure in the cooling system.

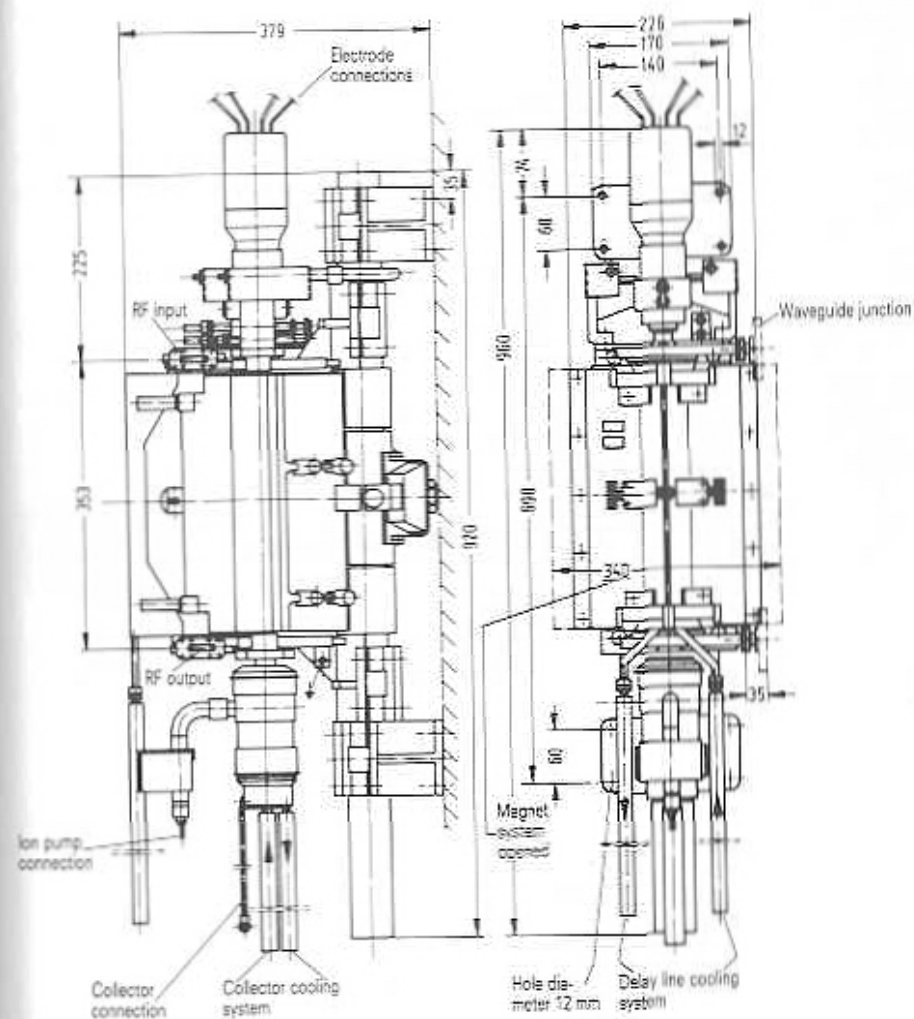
Magnet system MYH 1041

Dimensions in mm

$t_n = f(\text{duration of heating interruption})$
for $P_{2 \text{ min}} > 90\%$ of $P_{2 \text{ nom}}$

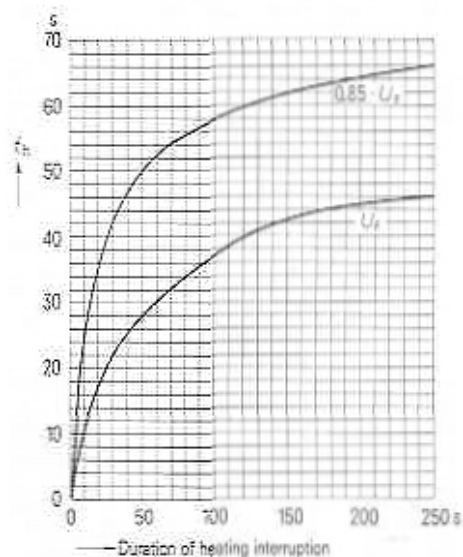

For replacement only

High power TWT for satellite earth stations in the frequency band 5.925 to 6.425 GHz.

In single-carrier operation the tube supplies a continuous output power of 3 kW at a minimum gain of 29 dB. In dual-carrier operation with 500 W per carrier, the 3rd order intermodulation product is at least 24 dB.

YH 1042 is provided with PPM focusing and operates with depressed collector voltage. The tube is easily replaceable in the magnet system MYH 1042. The RF power is coupled in and out by way of waveguides.

The collector is forced-air cooled and the delay line water-cooled.

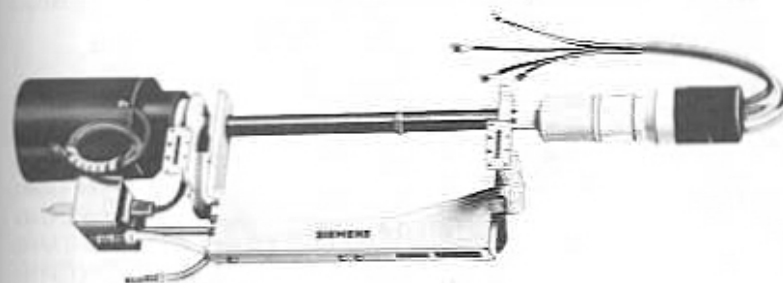

Traveling wave tube YH 1042

Weight of tube
Length of tube
Dimensions of tube packing
Waveguide
Flange
Mounting position

Ordering code Q42-X4654

approx. 9.5 kg net, approx. 38 kg gross
approx. 830 mm
660 mm × 660 mm × 1520 mm
F 70, DIN 47 302
UGF 70, DIN 47 303
vertically, collector up

Heating

Heater voltage	U_H	≈ 6.5	V ^{1) 5)}
Preheating voltage	U_{H-}	$0.85 \times U_H$	V
Heater current	I_H	≈ 2.5	A
Preheating time	t_h	≥ 5	min

indirectly heated by ac or dc (+ pole to cathode)
metal capillary cathode (MK cathode)

Characteristics ($f = 5.925 \dots 6.425$ GHz)

		min	nom	max	
Power gain ($P_2 = 3$ kW)	V_p	29			dB ²⁾
Gain slope ($P_2 = 2$ kW)	$\Delta V_p / \Delta f$		0.03		dB/MHz ^{2) 3)}
Gain variation ($P_2 = 1.5$ kW)	ΔV_p			2	dB ^{2) 5)}
VSWR	s		1.5	2.1	3)
Cold attenuation	α	60	80		dB
Harmonics up to 40 GHz		30			dB ⁴⁾

Operating characteristics for 3 kW CW single-carrier operation

Frequency band	f	5.925 ... 6.425	GHz	
Output power	P_2	3	kW	
Power gain	V_p	≥ 29	dB ²⁾	
Collector voltage	U_C	11	kV	
Delay line voltage	U_H	16 ... 18	kV ¹⁾	
Grid 2 voltage	U_{G2}	2.5 ... 4	kV ¹⁾	
Grid 1 voltage, negative	$-U_{G1}$	80 ... 400	V ¹⁾	
Collector current	I_C	1.4 ... 1.5	A ¹⁾	
Delay line current	I_H	≤ 150	mA	
Grid 2 current	I_{G2}	≤ 2	mA	
AM/PM conversion	K_p	≤ 4.5	°/dB	

¹⁾ The optimum setting value is indicated on the tube card, supplied with each tube.

²⁾ If the maximum deviation of the permissible heater voltage exceeds the actually set values by more than $\pm 2\%$, the operating performance of the tube will be impaired and its life shortened. For standby operation, the tube can be operated at 85% of the nominal heater voltage without the other electrode voltages applied.

The tube can be operated with full RF power immediately after the heater voltage is increased to nominal value and the other electrode voltages are applied simultaneously.

³⁾ At input and output of the cold tube throughout the frequency band 5.925 to 6.425 GHz.

⁴⁾ Level of all harmonics below the fundamental in the frequency band 5.925 to 6.425 GHz.

⁵⁾ At a load VSWR ≤ 1.1 .

⁶⁾ With gain equalizer.

Operating characteristics for multi-carrier operation with two carriers each of 500 W, spaced 5 MHz apart

Frequency band	f	5.925 ... 6.425	GHz	
Output power	P_2	1	kW	
Power gain	V_p	≥ 31	dB ³⁾	
3rd order intermodulation product	d_3	≥ 24	dB	
Collector voltage	U_C	11	kV	
Delay line voltage	U_H	16 ... 18	kV ¹⁾	
Grid 2 voltage	U_{G2}	2.4 ... 4	kV ¹⁾	
Grid 1 voltage, negative	$-U_{G1}$	80 ... 400	V ¹⁾	
Collector current	I_C	1.4 ... 1.5	A ¹⁾	
Delay line current	I_H	≤ 150	mA	
Grid 2 current	I_{G2}	≤ 2	mA	

Maximum ratings (absolute values)

Collector voltage	U_C	max	14	kV
Collector voltage ($P_2 = 3$ kW)	U_C	min	11	kV
($\Sigma P_2 = 2$ kW)	U_C	min	10.5	kV
($\Sigma P_2 = 1$ kW)	U_C	min	7.5	kV
($\Sigma P_2 = 0.5$ kW)	U_C	min	5.5	kV
Collector dissipation	P_C	max	20	kW
Delay line voltage	U_H	max	18.5	kV
Delay line current without RF	I_{H0}	max	60	mA
Delay line current with RF	I_H	max	160	mA
Grid 2 voltage	U_{G2}	max	4.5	kV
Grid 2 dissipation	P_{G2}	max	9	W
Grid 1 voltage, negative	$-U_{G1}$	max	2.2	kV
Grid 1 voltage, negative	$-U_{G1}$	min	50	V
Cathode current	I_K	max	1.7	A
CW output power	P_2	max	3.5	kW
Load VSWR	s_L	max	1.2	2)
Ambient temperature	t_{amb}	min	-20	°C
Ambient temperature	t_{amb}	max	60	°C

¹⁾ The optimum setting value is indicated on the tube card, supplied with each tube.

²⁾ A circulator must be provided at the input and output of the tube. The load VSWR may not exceed 1.2:1 in the frequency band 5.925 to 6.425 GHz and 2:1 out of the band.

³⁾ With gain equalizer.

General operating instructions

The TWT YH 1042 can only be operated in conjunction with the magnet system MYH 1042.

When mounting the magnet system the distance between the magnet system and large ferromagnetic parts (e.g. mounting supports) should be 50 mm and between the magnet system and small ferromagnetic parts (e.g. screws) 10 mm. The spacing between two magnet systems should be at least 170 mm. In order to replace the tube, the magnet system can be swung open along its axis of symmetry.

Details on the power supply, such as electrical characteristics, current and voltage monitoring, etc., as well as starting the YH 1042 are contained in separate specifications.

Cooling

To dissipate the heat developed, the collector must be cooled by forced air and the delay line by decalcified water.

Collector:

Collector dissipation	18	kW
Air flow rate	15	m ³ /min
Pressure drop	20	mbar
Inlet temperature	max 55	°C
Outlet temperature	max 140	°C

Delay line:

Water flow rate	4	l/min
Pressure drop	4	bar
Inlet temperature	max 65	°C
Outlet temperature	max 85	°C

The maximum permissible static pressure in cooling lines must not exceed 6 bar.

The tube must be protected such that the supply voltages are disconnected if there is a failure in the cooling system.

Magnet system MYH 1042

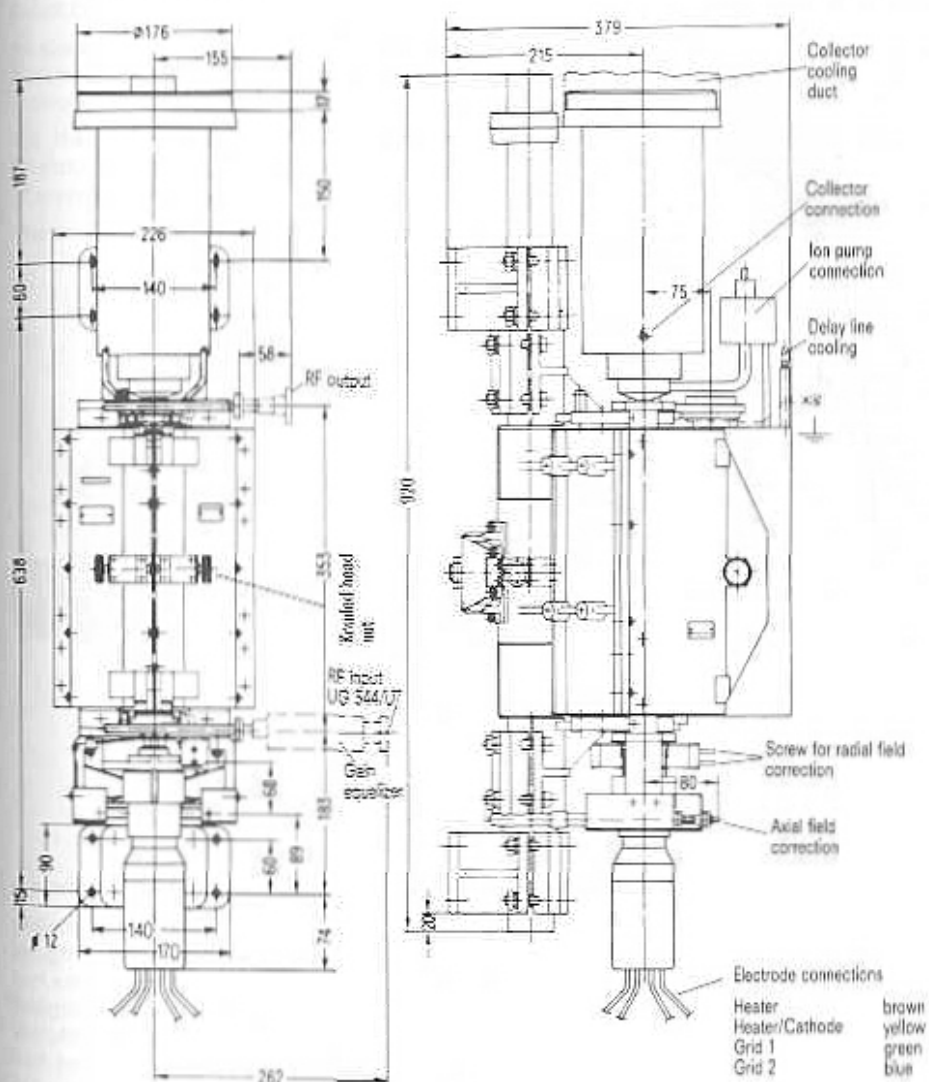

Dimensions in mm

$t_h = f$ (duration of heating interruption)
for $P_{2min} > 90\%$ of P_{2nom}

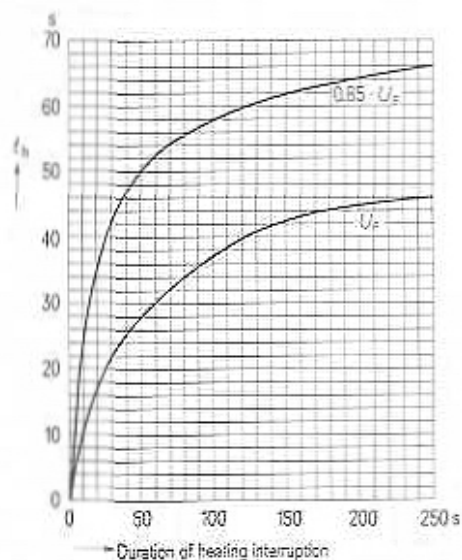

High power metal-ceramic TWT for satellite earth stations in the frequency band 5.925 to 6.425 GHz.

In single-carrier operation the tube supplies a continuous output power of 1.2 kW at a minimum gain of 30 dB. In dual-carrier operation with 75 W per carrier the 3rd order intermodulation product is at least 24 dB.

YH 1043 is provided with PPM focusing and operates with depressed collector voltage. The tube is easily replaceable in its magnet system. The RF power is coupled in and out by way of waveguides.

The complete system comprising collector, helix, and solenoid is forced-air cooled.



Traveling wave tube YH 1043

Weight of tube	approx. 11 kg
Weight of magnet system incl. cooling air duct	approx. 59 kg
Weight of tube incl. packing	approx. 70 kg
Weight of magnet system incl. cooling air duct and packing	approx. 107 kg
Tube length	approx. 610 mm
Dimensions of magnet system with tube	approx. 630 mm × 400 mm × 565 mm
Dimensions of tube packing	approx. 1160 mm × 900 mm × 890 mm
Dimensions of magnet system packing	approx. 680 mm × 680 mm × 1000 mm
Waveguide	WR 137
Flange	UG 344/U
Mounting position	vertically, collector up

Ordering code Q42-X4655

approx. 11 kg

approx. 59 kg

approx. 70 kg

approx. 107 kg

approx. 610 mm

approx. 630 mm × 400 mm × 565 mm

approx. 1160 mm × 900 mm × 890 mm

approx. 680 mm × 680 mm × 1000 mm

WR 137

UG 344/U

vertically, collector up

Heating

Heater voltage	U_F	6.0	V ¹⁾
Preheating voltage	U_{PF}	$0.85 \times U_F$	V
Heater current	I_F	3.2	A
Preheating time	t_h	≥ 5	min

indirectly heated by ac or dc metal capillary cathode

Characteristics ($f = 5.925 \dots 6.425$ GHz)

		min	nom.	max	
Power gain ($P_2 = 1.2$ kW)	V_p	30			dB
VSWR	s		1.5	2.1	²⁾
Cold attenuation	a		70		dB

Operating characteristics for 1.2 kW CW single-carrier operation

Frequency band	f	5.925 ... 6.425	GHz
Output power	P_2	1.2	kW
Power gain	V_p	≥ 30	dB
Collector voltage	U_C	7.0	kV
Helix voltage	U_H	8.8 ... 9.8	kV ³⁾
Grid 2 voltage	U_{G2}	5.5 ... 6.0	kV ³⁾
Cathode resistance	R_K	100	Ω
Helix current	I_H	≤ 15	mA
Grid 2 current	I_{G2}	≤ 2.5	mA
Collector current	I_C	0.8 ... 0.95	A ²⁾
Solenoid voltage	U_{SOL}	≤ 190	V
Solenoid current	I_{SOL}	10 ... 12.5	A ²⁾
AM/PM conversion	k_p	≤ 8	%dB

¹⁾ If the maximum deviation of the permissible heater voltage exceeds $\pm 1\%$ (absolute maximum ratings), the operating performance of the tube will be impaired and its life shortened. For stand-by operation, the tube can be operated at 65% of the nominal heater voltage without the other electrode voltages applied.

The tube can be operated with full RF power immediately after the heater voltage is increased to nominal value and the other electrode voltages are applied simultaneously.

²⁾ At input and output of the cold tube throughout the frequency band 5.925 to 6.425 GHz.

³⁾ The optimum setting value is indicated on the tube card, supplied with each tube.

Operating characteristics for multi-carrier operation with two carriers each of 75 W, spaced 5 MHz apart

Frequency band	f	5.925 ... 6.425	GHz
Output power	P_2	150	W
Power gain	V_p	≥ 33	dB
Gain variation	ΔV_p	≤ 3	dB
Gain slope	$\Delta V_p / \Delta f$	≤ 0.05	dB/MHz ²⁾
3rd order intermodulation product	d_3	≥ 24	dB
Collector voltage	U_C	4.0	kV
Helix voltage	U_H	8.8 ... 9.8	kV ¹⁾
Grid 2 voltage	U_{G2}	4.5 ... 6.0	kV ¹⁾
Cathode resistance	R_K	100	Ω
Helix current	I_H	≤ 15	mA
Grid 2 current	I_{G2}	≤ 2.5	mA
Collector current	I_C	0.8 ... 0.95	A ¹⁾
Solenoid voltage	U_{sol}	≤ 190	V
Solenoid current	I_{sol}	10 ... 12.5	A ¹⁾
AM/PM conversion	k_p	≤ 3	%dB

Maximum ratings (absolute values)

Collector voltage	U_C	max	8	kV
Collector voltage	U_C	min	3	kV
Collector current	I_C	max	1	A
Collector power dissipation	P_C	max	7	kW
Helix voltage	U_H	max	10.5	kV
Helix current	I_H	max	20	mA
Grid 2 voltage	U_{G2}	max	8	kV
Grid 2 dissipation	P_{G2}	max	20	W
Grid 1 voltage, negative	$-U_{G1}$	max	2	kV
Grid 1 voltage, negative	$-U_{G1}$	min	0	V
Output power	P_2	max	1.4	kW
Drive power	P_1	max	2.5	W
Load VSWR	s_L	max	1.3	²⁾
Ambient temperature	t_{amb}	min	-40	$^{\circ}\text{C}$
Ambient temperature	t_{amb}	max	55	$^{\circ}\text{C}$

¹⁾ The optimum setting value is indicated on the tube card, supplied with each tube.

²⁾ An absorption-type filter must be connected to the RF output. For the RF input, a circulator (VSWR < 1.1) is required.

³⁾ At a load VSWR ≤ 1.15 .

General operating instructions

The TWT YH 1043 can only be operated in conjunction with a magnet system MS 1043.

Details on power supply, such as electrical characteristics, current and voltage monitoring etc., as well as starting the YH 1043 are contained in separate specifications.

Cooling

To dissipate the heat, collector, helix, and solenoid are air-cooled in a common cooling system.

The following cooling data apply to operation at mean sea level.

Extraction air cooling:

Air flow rate	min 8	m ³ /min
Pressure drop	approx. 8	mbar
Inlet temperature	max 55	°C
Outlet temperature	max 140	°C ¹⁾

Forced-air cooling:

Air flow rate	min 8	m ³ /min
Pressure drop	approx. 14	mbar
Inlet temperature	max 55	°C
Outlet temperature	max 140	°C ¹⁾

Ordering codes

Designation	Ordering code
TWT YH 1043	Q42-X4655
Magnet system MS 1043	Q43-X3043
Air cooling duct YHZ 9585	Q81-X801

¹⁾ Measured 50 mm behind collector.

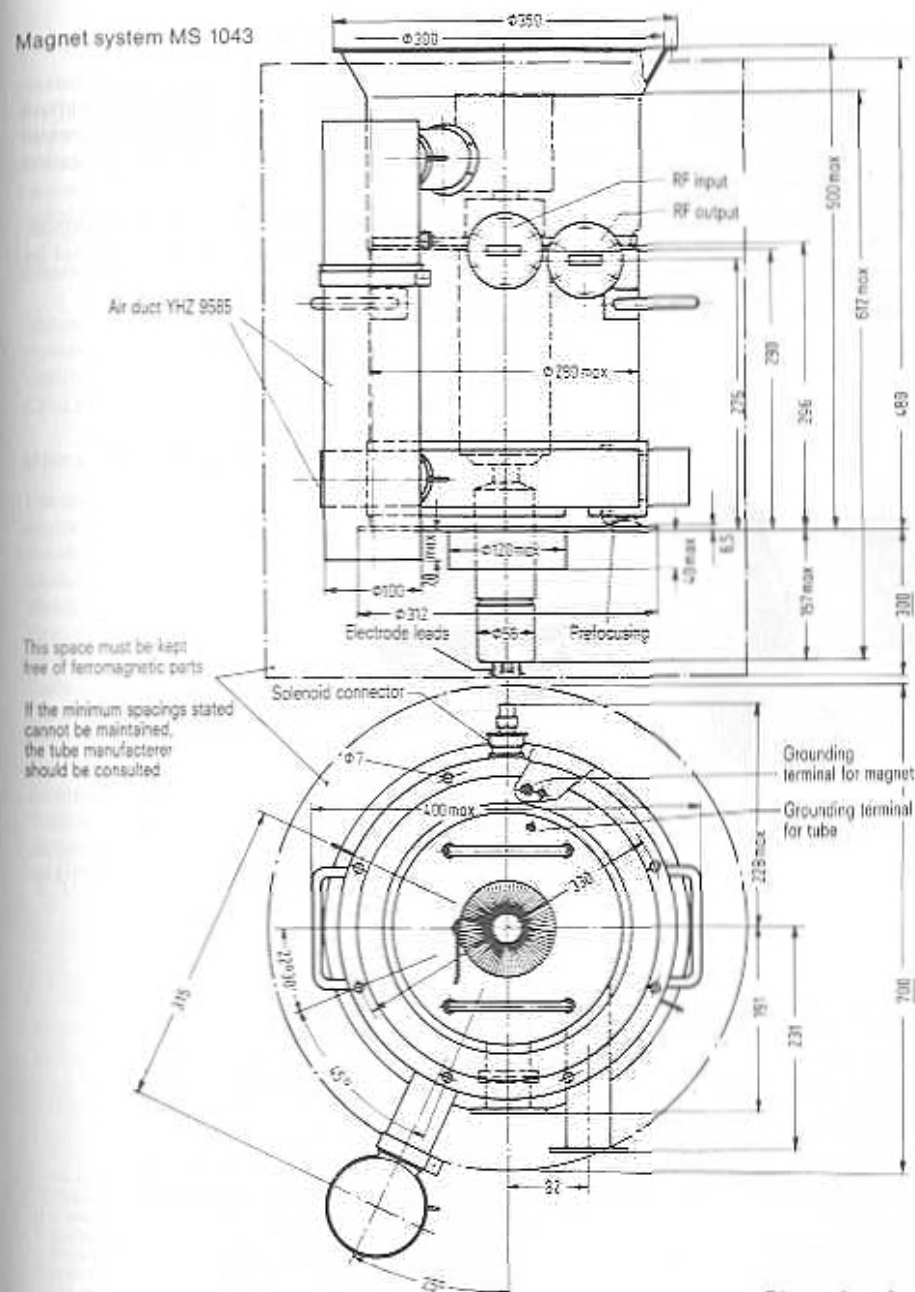
Magnet system MS 1043

Dimensions in mm

High power TWT with a saturation output power of 10 kW for satellite earth stations in the frequency band 5.925 to 6.425 GHz.

In single-carrier operation the tube supplies a continuous output power of 8 kW at a minimum gain of 30 dB; in multi-carrier operation at an output power of 1 kW the tube's gain is greater than 34 dB. In dual-carrier operation with 500 W per carrier the 3rd order intermodulation product is at least 28 dB.

YH 1045 is provided with PPM focusing and operates with depressed collector voltage. The tube is easily replaceable in its magnet system. The RF power is coupled in and out by way of waveguides.

Collector, delay line and solenoid are water-cooled.

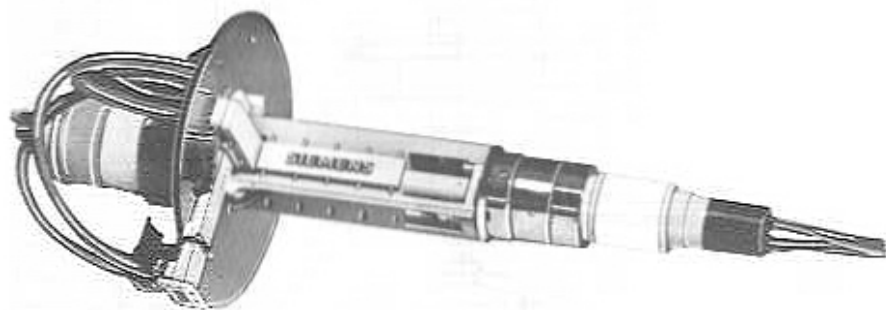

Traveling wave tube YH 1045

Weight of tube
Weight of magnet system
Length of tube
Dimensions of magnet system with tube
Dimensions of tube packing
Dimensions of magnet system packing
Waveguide
Flange for RF input
Flange for RF output
Mounting position

Ordering code Q42-X4657

approx. 35 kg net, approx. 145 kg gross
approx. 310 kg net, approx. 435 kg gross
approx. 1045 mm
approx. \varnothing 420 mm \times 1090 mm
approx. 870 mm \times 1030 mm \times 1770 mm
approx. 864 mm \times 834 mm \times 1074 mm
WR 137 or R 70, DIN 47302
CPR 137 or PDR 70, DIN 47303
CMR 137 or UER 70, DIN 47303
vertically, collector up

Heating

Heater voltage	U_r	4.2 ... 6	V ¹⁾²⁾
Preheating voltage	U_{pr}	$0.85 \times U_r$	V
Heater current	I_r	≈ 15	A
Preheating time	t_h	≤ 5	min
indirectly heated by ac or dc metal capillary cathode			

Characteristics ($f = 5.925 \dots 6.425$ GHz)

		min	nom	max	
Saturation power	P_{SAT}		10		kW
Power gain ($P_2 = 8$ kW)	V_p	30	34		dB
VSWR	S		1.5	2.6	³⁾
Cold attenuation	α		80		dB

Operating characteristics for 8 kW CW single-carrier operation

Frequency band	f	5.925 ... 6.425	GHz
Output power	P_z	8	kW
Power gain	V_s	≥ 30	dB
Collector voltage	U_C	13.5	kV
Delay line voltage	U_H	17 ... 21	kV ¹⁾
Grid 2 voltage	U_{G2}	6 ... 11.5	kV ¹⁾
Grid 1 voltage, negative	$-U_{G1}$	50 ... 400	V ¹⁾
Collector current without RF	I_{C0}	2.7 ... 3.2	A ¹⁾
Delay line current	I_H	≤ 110	mA
Grid 2 current	I_{G2}	≤ 2.5	mA
Solenoid voltage 1	U_{SOL1}	≤ 12	V
Solenoid voltage 2	U_{SOL2}	≤ 350	V
Solenoid current 1	I_{SOL1}	0.2 ... 8	A ¹⁾
Solenoid current 2	I_{SOL2}	8 ... 12.5	A ¹⁾
AM/PM conversion ($P_2 = 4$ kW)	K_p	≤ 3	°/dB

¹⁾ The optimum setting value is indicated on the tube card, supplied with each tube.

²⁾ If the maximum deviation of the max. heater voltage exceeds the actually set values by more than $\pm 1\%$, the operating performance of the tube will be impaired and its life shortened.

For stand-by operation, the tube can be operated at 85% of the nominal heater voltage without the other electrode voltages applied. The tube can be operated with full RF power immediately after the heater voltage is increased to nominal value and the other electrode voltages are applied simultaneously.

³⁾ At the input and output of the cold tube throughout a frequency band 5.925 to 6.425 GHz.

Operating characteristics for multi-carrier operation with two carriers each of 500 W, spaced 5 MHz apart.

Frequency band	f	5.925 ... 6.425	GHz
Output power	P_2	1	kW
Power gain	V_0	≥ 34	dB
Gain variation (500 MHz)	ΔV_0	≈ 5	dB
Gain slope	$\Delta V_0/\Delta f$	≈ 0.08	dB/(MHz ²)
3rd order intermodulation product	d_3	≥ 28	dB
Collector voltage	U_C	13.5	kV
Delay line voltage	U_H	17 ... 21	kV ²⁾
Grid 2 voltage	U_{G2}	6 ... 11.5	kV ²⁾
Grid 1 voltage, negative	$-U_{G1}$	50 ... 400	V ²⁾
Collector current without RF	I_{C0}	2.7 ... 3.2	A ²⁾
Delay line current	I_H	≤ 90	mA
Grid 2 current	I_{G2}	≤ 2.5	mA
Solenoid voltage 1	$U_{SOL.1}$	≤ 12	V
Solenoid voltage 2	$U_{SOL.2}$	≤ 350	V
Solenoid current 1	$I_{SOL.1}$	0.2 ... 8	A ²⁾
Solenoid current 2	$I_{SOL.2}$	8 ... 12.5	A ²⁾

Maximum ratings (absolute values)

Collector voltage	U_C	max	20	kV
Collector voltage	U_C	min	13	kV
Collector dissipation	P_C	max	70	kW
Collector current	I_C	max	3.5	A
Delay line voltage	U_H	max	22	kV
Delay line current without RF	I_{H0}	max	100	mA ²⁾
Delay line current with RF	I_H	max	120	mA
Grid 2 voltage	U_{G2}	max	12.5	kV
Grid 2 dissipation	P_{G2}	max	50	W
Grid 1 voltage, negative	$-U_{G1}$	max	2.5	kV
Grid 1 voltage, negative	$-U_{G1}$	min	50	V
CW output power	P_2	max	10	kW
Load VSWR	S_L	max	1.15	¹⁾
Ambient temperature	t_{amb}	min	-20	°C ²⁾
Ambient temperature	t_{amb}	max	55	°C

¹⁾ At a load VSWR ≤ 1.1 .

²⁾ The optimum setting value is indicated on the tube card, supplied with each tube.

³⁾ With a new tube the delay line current without RF after turning-on must be equal to or less than 50 mA.

⁴⁾ A circulator must be provided at the RF input and output of the tube. The load VSWR may not exceed 1.15:1 in the frequency band 5.925 to 6.425 GHz and 2:1 out of band.

⁵⁾ Without water in the cooling system.

General operating instructions

The TWT YH 1045 can be operated only in conjunction with the focusing system MS 1045.

Details on the power supply, such as electrical data, current and voltage monitoring etc., and operating instructions are contained in separate specifications.

Cooling

To dissipate the heat developed, collector, delay line, and solenoid have to be cooled by distilled and deionized water.

Collector:				
Collector dissipation	70	40	40	kW
Water flow rate	55	30	75	l/min
Pressure drop	≈ 1	≈ 0.5	≈ 2	bar
Pressure at outlet	≥ 4	≥ 4	1)	bar
Delay line:				
Water flow rate		12		l/min
Pressure drop		4.5		bar
Solenoid:				
Water flow rate		4		l/min
Pressure drop		≈ 1.5		bar
Inlet temperature		max 65		°C
Outlet temperature		max 85		°C

The maximum permissible static pressure in cooling lines amounts to 10 bar.

In view of the voltage difference between collector and delay line (ground terminal) appropriate insulation of the hose pipes has to be ensured.

Coolant conductivity	≤ 2	μS
Leakage current between collector and ground	≤ 1	mA

The hose pipes are not allowed to touch metal parts.

Ordering codes

Designation	Ordering code
TWT YH 1045	Q42-X4657
Magnet system MS 1045	Q43-X3045

1) open cooling circuit

Heating

Heater voltage	U_p	6.3	V ¹⁾
Heater current	I_p	≈ 2	A
Preheating time	t_h	≥ 3	min

indirectly heated by ac or dc (+pole to cathode)
metal capillary dispenser cathode

Characteristics ($f = 5.850 \dots 6.425$ GHz)

		min	nom	max	
Power gain ($P_2 = 600/700$ W)	V_D	43			dB
VSWR at input	s			1.6	²⁾
Cold attenuation	α		90		dB

Operating characteristics

		YH 1047-A1	YH 1047-A2	
Frequency band	f	5.850 ... 6.425	5.850 ... 6.425	GHz
Output power	P_2	600	700	W
Power gain	V_D	≥ 43	≥ 43	dB
Collector voltage	U_C	5.7 ... 5.9	5.7 ... 5.9	kV
Helix voltage	U_H	10.9 ... 11.3	10.9 ... 11.3	kV ³⁾
Grid 2 voltage	U_{G2}	U_H	U_H	kV
Helix current	I_H	≤ 20	≤ 20	mA
Grid 2 current	I_{G2}	-0.4 ... +2	-0.4 ... +2	mA
Cathode current	I_K	≤ 445	≤ 460	mA
AM/PM conversion	k_p	≈ 1.5	= 2	%/dB

Operating characteristics

		YH 1047-A1	YH 1047-A2	
Frequency range	f	5.850 ... 6.425	5.850 ... 6.425	GHz
Output power	P_2	60	70	W
Power gain	V_D	≥ 43	≥ 43	dB
Gain variation	ΔV_D	≤ 2	≤ 2	dB ⁴⁾
Gain slope	$\Delta V_D / \Delta f$	≤ 0.02	≤ 0.02	dB/MHz ⁴⁾
3rd order intermodulation product (2 × 30 W)	d_3	≥ 30.5		dB
(2 × 35 W)	d_3		≥ 31.5	dB
Collector voltage	U_C	5.7 ... 5.9	5.7 ... 5.9	kV
Helix voltage	U_H	10.9 ... 11.3	10.9 ... 11.3	kV ³⁾
Grid 2 voltage	U_{G2}	U_H	U_H	kV
Helix current	I_H	≤ 20	≤ 20	mA
Grid 2 current	I_{G2}	-0.4 ... +2	-0.4 ... +2	mA
Cathode current	I_K	≤ 445	≤ 460	A

¹⁾ If the maximum deviation of the heater voltage exceeds the absolute limits of ±0.3 V, the operating performance of the tube will be impaired and its life shortened.

²⁾ At tube operation throughout the frequency band 5.850 to 6.425 GHz.

³⁾ The optimum setting value is indicated on the tube card, supplied with each tube.

⁴⁾ At a load VSWR ≤ 1.1.

Maximum ratings (absolute values)

Collector voltage	U_C	max	7.5	kV
Collector voltage	U_C	min	5.7	kV
Helix voltage	U_H	max	11.7	kV
Helix voltage	U_H	min	10.2	kV
Helix current	I_H	max	25	mA ¹⁾
Grid 2 voltage	U_{G2}	max	$U_H + 0.25$	kV
Grid 2 current	I_{G2}	max	2.5	mA
Cathode current	I_K	max	450	mA
RF output power	P_2	max	700	W
RF input power	P_1	max	100	mW
Load VSWR	s_L	max	1.7	
Ambient temperature	t_{amb}	min	-20	°C
Ambient temperature	t_{amb}	max	50	°C
Storage temperature	t_{stg}	min	-40	°C
Storage temperature	t_{stg}	max	75	°C
Height above mean sea level		max	3000	m

For general instructions, recommendations for designing a power supply, and detailed data refer to performance specifications.

¹⁾ Trip level for helix overcurrent protection circuit.

High power TWT for satellite earth stations in the frequency band 14.0 to 14.5 GHz.

In single-carrier operation the tube supplies a continuous output power of up to 2.3 kW at a minimum gain of 45 dB. In dual-carrier operation with 50 W per carrier the 3rd order intermodulation product is at least 30 dB.

The YH 1420 is provided with an integral PPM focusing system, consisting of samarium cobalt rings. The tube is designed to operate with depressed collector voltage. Waveguides are provided for RF input and RF output.

The collector is forced-air cooled, the delay line is water-cooled.

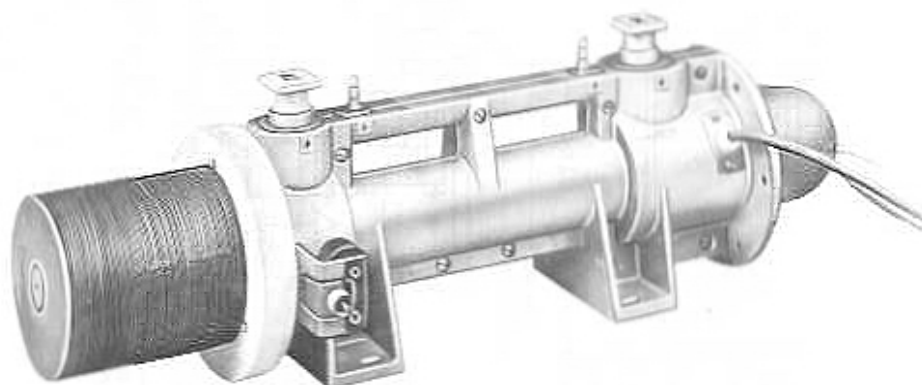

Traveling wave tube YH 1420

Weight
Dimensions of tube
Dimensions of packing
RF connectors
Mounting position

Ordering code Q42-X4619

approx. 15 kg net, approx. 67 kg gross
approx. 608 mm × 158 mm × 180 mm
approx. 1160 mm × 880 mm × 760 mm
Flange UG 419/U, waveguide WR 62
vertically, collector up or down

Heating

Heater voltage	U_F	6.5	V ¹⁾
Preheating voltage	U_{F_1}	5.5	V
Heater current	I_F	≈ 3.1	A
Preheating time	t_h	≥ 5	min

indirectly heated by dc (+ pole to cathode)
metal capillary cathode

Characteristics ($f = 14.0 \dots 14.5$ GHz)

		min	nom	max	
Power gain ($P_2 = 2$ kW)	V_o	45			dB
VSWR	s		1.5	2.1	*)
Cold attenuation	α		70		dB

Operating characteristics

		14.0 ... 14.5	14.0 ... 14.5	GHz
Frequency range	f	14.0 ... 14.5	14.0 ... 14.5	GHz
Output power	P_2	2	1	kW
Power gain	V_o	≥ 45	≥ 45	dB
Gain variation over the band	ΔV_o	≤ 2.2	≤ 3	dB ²⁾
Gain slope	$\Delta V_o / \Delta f$	≤ 0.03	≤ 0.06	dB/MHz ³⁾
Collector voltage	U_c	12	12	kV
Delay line voltage	U_d	18 ... 21	18 ... 21	kV ⁴⁾
Grid 2 voltage	U_{G2}	8 ... 13	8 ... 13	kV ⁴⁾
Delay line current	I_d	≤ 50	≤ 50	mA
Grid 2 current	I_{G2}	-0.1 ... +2	-0.1 ... +2	mA
Cathode current	I_k	0.6 ... 0.75	0.6 ... 0.75	A ⁴⁾
Ion getter pump voltage	U_{ip}	3	3	kV
AM/PM conversion	k_c	≈ 2.4	≈ 1	%/dB
3rd order intermodulation product (2 × 500 W)	σ_3		≥ 17	dB
(2 × 100 W)	σ_3		≥ 30	dB

¹⁾ If the maximum deviation of the permissible heater voltage exceeds the actually set values by more than ± 2%, the operating performance of the tube will be impaired and its life shortened. For stand-by operation, the tube can be operated at a heater voltage reduced to 5.5 V without electrode voltages applied.

The tube can be operated with full RF power immediately after the heater voltage is increased to nominal value and the other electrode voltages are applied simultaneously.

²⁾ At input and output of the cold tube throughout the frequency band 14.0 to 14.5 GHz.

³⁾ At a load VSWR ≈ 1.15.

⁴⁾ The optimum setting value is indicated on the tube card, supplied with each tube.

Maximum ratings (absolute values)

Collector voltage	U_C	max	14	kV
Collector voltage	U_C	min	7	kV
Collector dissipation	P_C	max	11	kW
Delay line voltage	U_H	max	22	kV
Delay line current	I_H	max	70	mA
Grid 2 voltage	U_{G2}	max	14	kV
Grid 2 current, positive	$+I_{G2}$	max	2	mA
Grid 2 current, negative	$-I_{G2}$	max	0.2	mA
Grid 2 dissipation	P_{G2}	max	26	W
Cathode current	I_K	max	0.85	A
CW output power	P_2	max	3	kW
Input power	P_1	max	1	W
Load VSWR	S_L	max	1.35	
Ambient temperature	t_{amb}	min	5	°C
Ambient temperature	t_{amb}	max	55	°C
Storage temperature	t_{stg}	min	-40	°C ¹⁾
Storage temperature	t_{stg}	max	70	°C ¹⁾
Height above mean sea level		max	1000	m

For general instructions, recommendations for designing a power supply, and detailed data refer to performance specifications.

¹⁾ Cooling channels dehydrated.

Mounting instructions

The tube should be mounted at a distance of at least 5 cm to large ferromagnetic parts (rack panels, doors, etc.). External fields at the tube's surface should not exceed 40 A/cm.

Cooling

To dissipate the heat developed, the collector must be cooled by forced air and the delay line by decaicified water.

Collector:			
Collector dissipation	9	11	kW
Air flow rate	8	10	m ³ /min
Pressure drop	8	15	mbar
Inlet temperature	max 55	max 55	°C
Outlet temperature	max 150	max 150	°C ¹⁾
Delay line:			
Water flow rate	3		l/min
Pressure drop	5		bar
Inlet temperature	max 66		°C
Outlet temperature	max 70		°C

¹⁾ Measured at 50 mm behind collector.

Outline drawing YH 1420

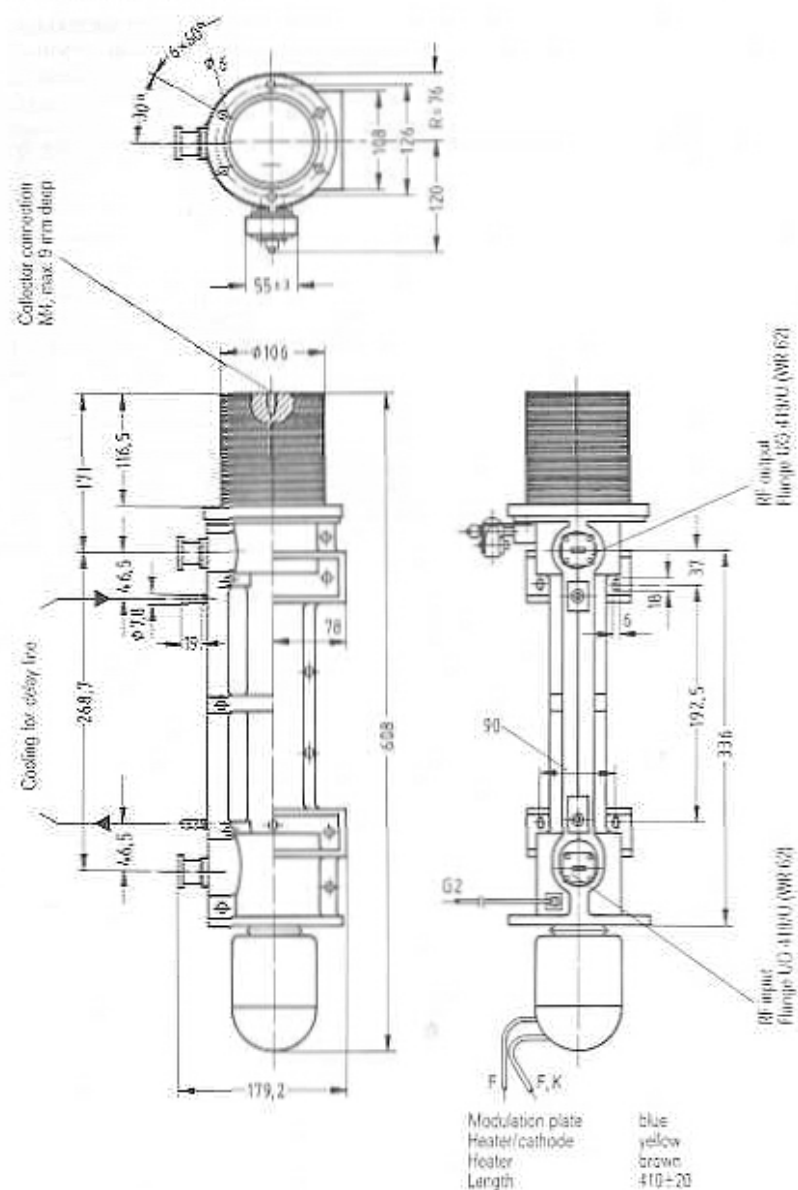

Dimensions in mm

High power TWT for satellite earth stations in the frequency band 14.0 to 14.5 GHz.

The tube supplies a continuous output power of 600 W at a minimum gain of 50 dB. In dual-carrier operation with 30 W per carrier the 3rd order intermodulation product is at least 30 dB.

YH 1421 is provided with an integral PPM focusing system, consisting of samarium cobalt rings. The tube is designed to operate with depressed collector voltage. A coaxial connector is provided for the RF input and a waveguide for the RF output.

The tube is forced-air cooled.

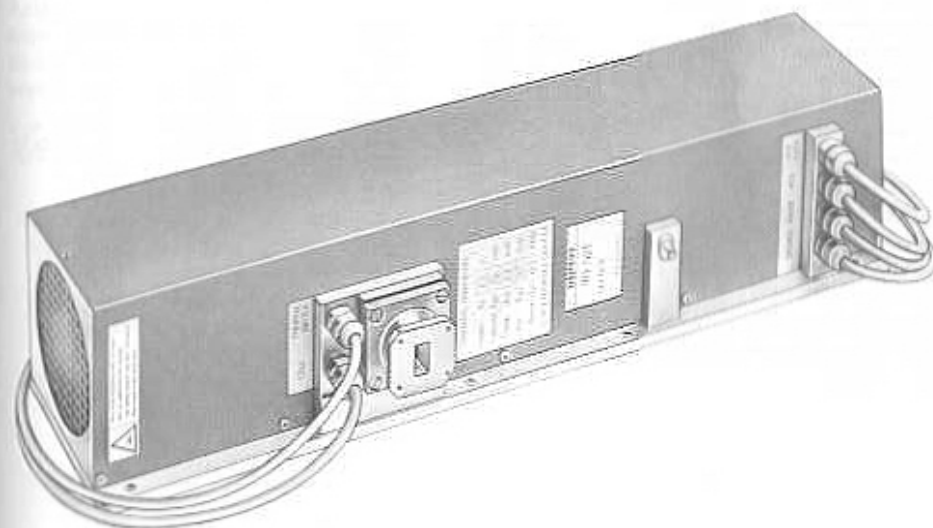

Traveling wave tube YH 1421

- Weight of tube
- Dimensions of tube
- Dimensions of packing
- RF input
- RF output
- Mounting position

Ordering code Q42-X4624

- approx. 6 kg net, approx. 18 kg gross
- approx. 500 mm × 150 mm × 110 mm
- approx. 895 mm × 460 mm × 450 mm
- SMA connector (female)
- Waveguide WR 75, flange UBR 120
- any

Heating

Heater voltage	U_p	6.3	V ¹⁾
Heater current	I_p	≈ 2	A
Preheating time	t_h	≥ 5	min

indirectly heated by ac or dc (+ pole to cathode)
metal capillary cathode

Characteristics ($f = 14.0 \dots 14.5$ GHz)

		min	nom	max	
Power gain ($P_2 = 600$ W)	V_p	50			dB
VSWR at input	s		1.6		²⁾
Cold attenuation	α		90		dB
Noise figure ($P_1 = 0$)	NF		32		dB

Operating characteristics

Frequency range	f	14.0 ... 14.5	14.0 ... 14.5	GHz
Output power	P_2	600	60	W
Power gain	V_p	≥ 50	≥ 53	dB
Gain variation over the band	ΔV_p	≤ 0.5	≤ 3	dB ³⁾
Gain slope	$\Delta V_p / \Delta f$	≤ 0.015	≤ 0.02	dB/MHz ³⁾
Collector voltage	U_C	5.5	5.5	kV
Helix voltage	U_H	10.2 ... 11	10.2 ... 11	kV ⁴⁾
Grid 2 voltage	U_{G2}	5.5 ... 6.1	5.5 ... 6.1	kV
Helix current	I_H	≤ 15	≤ 15	mA
Grid 2 current	I_{G2}	≤ 2	≤ 2	mA
Cathode current	I_K	≤ 450	≤ 450	mA
AM/PM conversion	k_p	= 3	= 1.5	⁵⁾ /dB ²⁾
3rd order intermodulation product (2×30 W)	d_3		≥ 30	dB

¹⁾ If the maximum deviation of the heater voltage exceeds the absolute limits of ± 0.2 V, the operating performance of the tube will be impaired and its life shortened.

²⁾ At tube operation throughout the frequency band 14.0 to 14.5 GHz.

³⁾ At a load VSWR ≤ 1.5.

⁴⁾ The optimum setting value is indicated on the tube card, supplied with each tube.

⁵⁾ AM/PM conversion is the phase shift of the RF output signal, when changing the input power by 1 dB.

Maximum ratings (absolute values)

Collector voltage	U_C	max	6.5	kV
Collector voltage	U_C	min	5.3	kV
Collector dissipation	P_C	max	3.3	kW
Helix voltage	U_H	max	11.2	kV
Helix voltage	U_H	min	10	kV
Helix current	I_H	max	20	mA ¹⁾
Grid 2 voltage	U_{G2}	max	6.5	kV
Grid 2 current	I_{G2}	max	-0.5/+2.5	mA
Cathode current	I_K	max	500	mA
RF output power	P_2	max	700	W
RF input power	P_1	max	6	mW
Load VSWR	S_L	max	1.5	
Ambient temperature	t_{amb}	min	-20	°C
Ambient temperature	t_{amb}	max	50	°C
Storage temperature	t_{stg}	min	-40	°C
Storage temperature	t_{stg}	max	75	°C
Height above mean sea level		max	3000	m

For general instructions, recommendations for designing a power supply, and detailed data refer to performance specifications.

¹⁾ Trip level for helix overcurrent protection circuit.

Cooling

A forced-air flow is used to dissipate the heat developed by the collector dissipation. The following cooling data applies to operation at mean sea level.

Collector dissipation	3000	3300	W
Air flow rate	4	4.5	m ³ /min
Pressure drop	= 12	≈ 15	mbar
Inlet temperature	25	25	°C

The temperature is monitored by the integrated thermal switch. The thermal switch has to be part of an interlock circuit which is provided to disconnect the tube upon exceeding the max. permissible temperature.

Outline drawing YH 1421

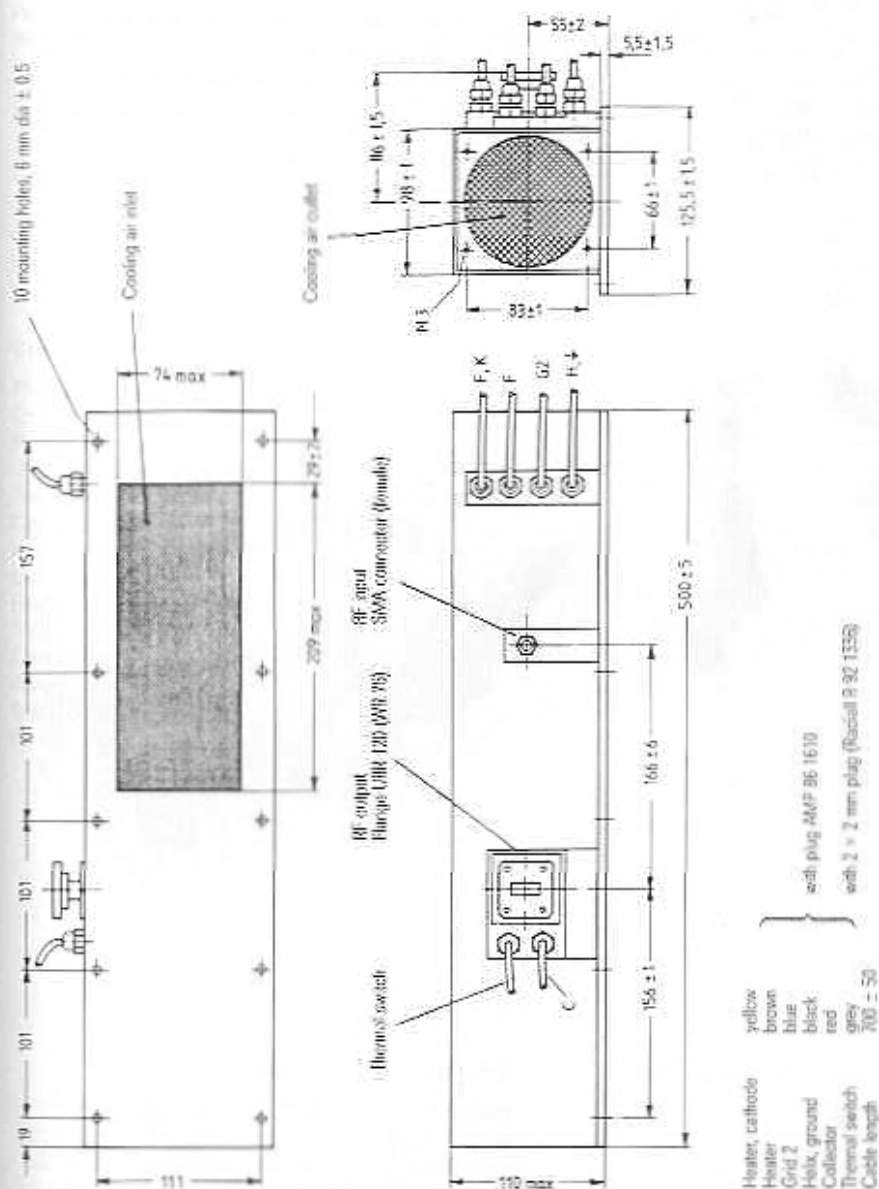

Dimensions in mm

High power TWT for satellite earth stations in the frequency band 14.0 to 14.5 GHz.

The tube supplies a continuous output power of 300 W at a minimum gain of 45 dB. In dual-carrier operation with 15 W per carrier the 3rd order intermodulation product is at least 30 dB

YH 1422 is provided with an integral PPM focusing system consisting of samarium cobalt rings. The tube is designed to operate with depressed collector voltage. A coaxial connector is provided for the RF input and a waveguide for the RF output.

The tube is forced-air cooled.

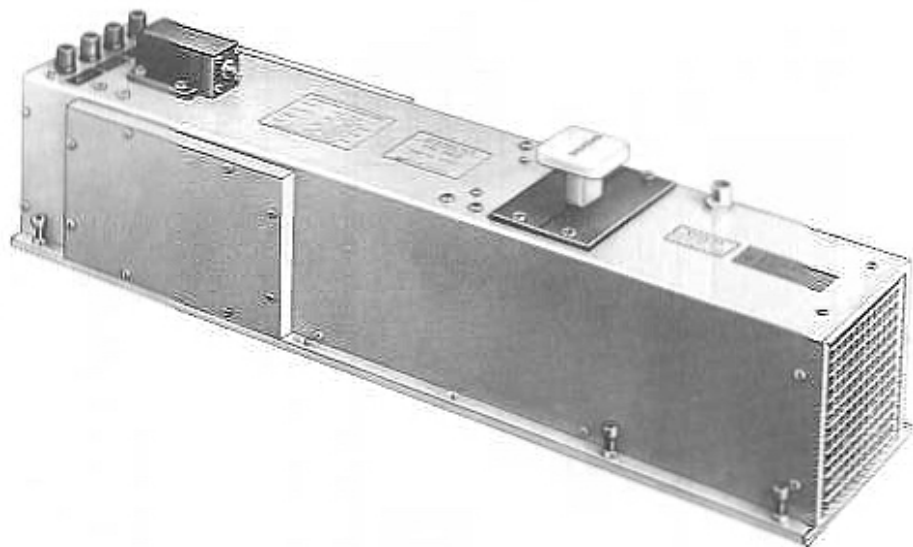

Traveling wave tube YH 1422

Weight of tube
Dimensions of tube
Dimensions of packing
RF input
RF output
Mounting position

Ordering code Q42-X4625

approx. 6.5 kg net, approx. 18.5 kg gross
approx. 545 mm × 135 mm × 138 mm
approx. 895 mm × 460 mm × 450 mm
SMA connector (female)
Waveguide WR 75, flange UBR 120
any

Heating

Heater voltage	U_F	5.3	V ¹⁾
Heater current	I_F	≈ 2	A
Preheating time	t_h	≥ 5	min

indirectly heated by ac or dc (+pole to cathode)
metal capillary cathode

Characteristics ($f = 14.0 \dots 14.5$ GHz)

		min	nom	max	
Power gain ($P_2 = 300$ W)	V_p	50			dB
VSWR at input	S			1.6	²⁾
Cold attenuation	α		90		dB
Noise figure ($P_1 = 0$)	NF			32	dB

Operating characteristics

		14.0 ... 14.5	14.0 ... 14.5	GHz
Frequency range	f	14.0 ... 14.5	14.0 ... 14.5	GHz
Output power	P_2	300	30	W
Power gain	V_p	≥ 45	≥ 49	dB
Gain variation over the band	ΔV_p	≤ 1	≤ 3	dB ³⁾
Gain slope	$\Delta V_p / \Delta f$	≤ 0.015	≤ 0.02	dB/MHz ³⁾
Collector voltage	U_c	4.8	4.8	kV
Helix voltage	U_H	9.3 ... 9.9	9.3 ... 9.9	kV ⁴⁾
Grid 2 voltage	U_{G2}	U_H	U_H	kV
Helix current	I_H	≤ 10	≤ 10	mA
Grid 2 current	I_{G2}	≤ 2	≤ 2	mA
Cathode current	I_k	≤ 320	≤ 320	mA
AM/PM conversion	K_{ϕ}	= 3	= 1	⁵⁾ /dB ⁵⁾
3rd order intermodulation product (2 × 15 W)	\mathcal{G}_2		≥ 30	dB

¹⁾ If the maximum deviation of the heater voltage exceeds the absolute limits of ±0.2 V, the operating performance of the tube will be impaired and its life shortened.

²⁾ At tube operation throughout the frequency band 14.0 to 14.5 GHz.

³⁾ At a load VSWR ≤ 1.15.

⁴⁾ The optimum setting value is indicated on the tube card, supplied with each tube.

⁵⁾ AM/PM conversion is the phase shift of the RF output signal, when changing the input power by 1 dB.

Maximum ratings (absolute values)

Collector voltage	U_C	max	5.5	kV
Collector voltage	U_C	min	4.5	kV
Collector dissipation	P_C	max	2	kW
Helix voltage	U_H	max	11.0	kV
Helix voltage	U_H	min	8.5	kV
Helix current	I_H	max	15	mA ¹⁾
Grid 2 voltage	U_{G2}	max	U_H	kV
Grid 2 current	I_{G2}	max	-0.5/+2.5	mA
Cathode current	I_K	max	340	mA
RF output power	P_2	max	350	W
RF input power	P_1	max	10	mW
Load VSWR	s_L	max	1.5	
Ambient temperature	t_{amb}	min	-20	°C
Ambient temperature	t_{amb}	max	50	°C
Storage temperature	t_{stg}	min	-40	°C
Storage temperature	t_{stg}	max	75	°C
Height above mean sea level		max	3000	m

For general instructions, recommendations for designing a power supply, and detailed data refer to performance specifications.

¹⁾ Trip level for helix overcurrent protection circuit.

Cooling

A forced-air flow is used to dissipate the heat, developed by the collector dissipation. The following cooling data applies to operation at mean sea level.

Collector dissipation	1600	2000	W
Air flow rate	2.5	3.2	m ³ /min
Pressure drop	≈ 5	≈ 8	mbar
Inlet temperature	25	25	°C

The temperature is monitored by the integrated thermal switch. The thermal switch has to be part of an interlock circuit which is provided to disconnect the tube upon exceeding the max. permissible temperature.

Heating

Heater voltage	U_F	≈ 6.5	V ¹⁾
Heater current	I_F	≈ 1.4	min
Preheating time	t_h	≈ 5	min

Indirectly heated by dc (+pole to cathode)
metal capillary cathode

Characteristics ($f = 28.7 \dots 30.0$ GHz)

		min	nom	max	
Power gain ($P_2 = 1.3$ kW)	V_G	43			dB
VSWR at input	s			1.85	†)
Cold attenuation	α		70		dB
Noise figure ($P_1 = 1$ kW)	NF			38	dB

Operating characteristics

Frequency range	f	28.7 ... 30.0	GHz
Output power	P_2	1.3	kW
Power gain	V_G	≥ 43	dB
Gain variation	ΔV_G	$\leq \pm 1$	dB/200 MHz ²⁾
Collector voltage	U_C	12	kV
Delay line voltage	U_H	24 ... 26.5	kV ³⁾
Grid 2 voltage	U_{G2}	14 ... 16	kV ⁴⁾
Delay line current	I_H	≤ 35	mA
Grid 2 current	I_{G2}	-0.1 ... +1	mA
Cathode current	I_K	350 ... 500	mA
AM/PM conversion	k_p	≈ 5	°/dB ⁵⁾

¹⁾ If the maximum deviation of the permissible heater voltage exceeds the actually set values by more than $\pm 2\%$, the operating performance of the tube will be impaired and its life shortened.

²⁾ At tube operation throughout the frequency band 28.7 to 30.0 GHz.

³⁾ At load VSWR ≤ 1.2 .

⁴⁾ The exact setting value is indicated on the tube card, supplied with each tube.

⁵⁾ AM/PM conversion is the phase shift of the RF output signal when changing the input power by 1 dB.

Maximum ratings (absolute values)

Collector voltage	U_C	max	15	kV
Collector voltage	U_C	min	11	kV
Collector dissipation	P_C	max	7	kW
Delay line voltage	U_H	max	28	kV
Delay line current	I_H	max	40	mA ¹⁾
Grid 2 voltage	U_{G2}	max	26	kV
Grid 2 current	I_{G2}	max	1.5	mA
Cathode current	I_K	max	550	mA
RF output power	P_2	max	1.8	kW
Load VSWR	s_L	max	1.3	
Ambient temperature	t_{amb}	min	0	°C
Ambient temperature	t_{amb}	max	50	°C
Storage temperature	t_{stg}	min	-62	°C
Storage temperature	t_{stg}	max	75	°C
Height above mean sea level		max	1000	m

For general instructions, recommendations for designing a power supply, and detailed data refer to performance specifications.

¹⁾ Trip level for helix overcurrent protection circuit.

Cooling

To dissipate the heat developed, the collector must be cooled by forced air and the delay line by decalcified water.

Collector:		
Air flow rate	6	m ³ /min
Pressure drop	8	mbar
Inlet temperature	≤ 50	°C
Delay line:		
Water flow rate	1.5	l/min
Pressure drop	≤ 5.3	bar
Inlet temperature	≤ 50	°C
Outlet temperature	≤ 65	°C

The maximum permissible static pressure in cooling lines must not exceed 10 bar.

Outline drawing YH 3020

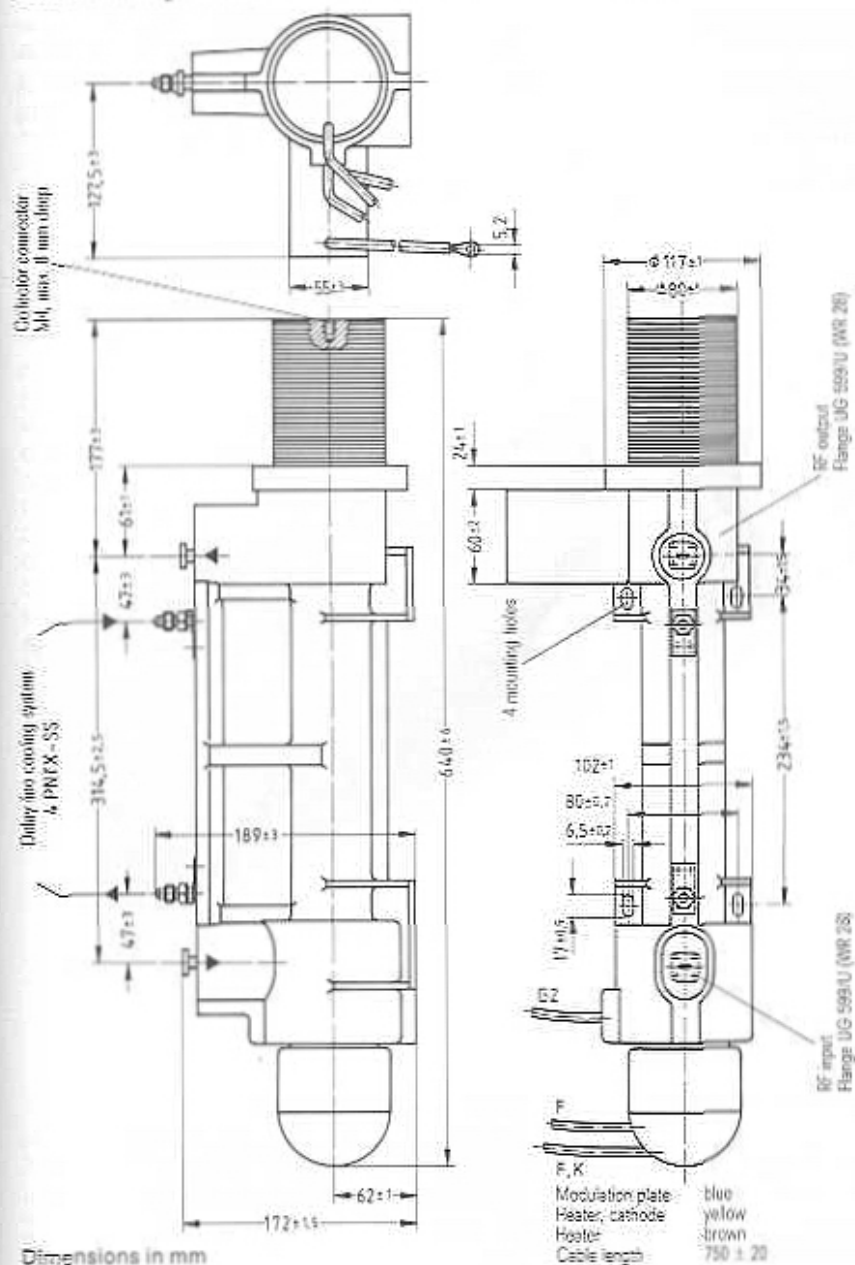

High power TWT for satellite earth stations in the frequency band 27.5 to 29.5 GHz.

The tube supplies a continuous output power of 350 W at a minimum gain of 45 dB. In dual-carrier operation with 20 W per carrier the 3rd order intermodulation product is at least 28 dB

YH 3025 is provided with an integral PPM focusing system consisting of samarium cobalt rings and operates with depressed collector voltage. The RF power is coupled in and out by way of waveguides.

The tube is forced-air cooled.

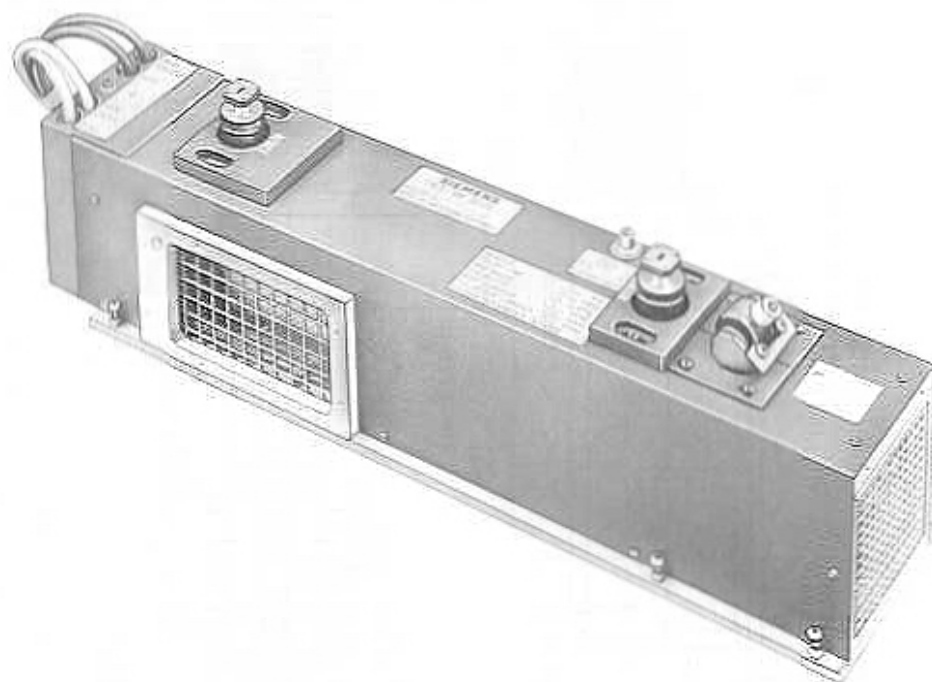

Traveling wave tube YH 3025

Weight of tube
Dimensions of tube
Dimensions of packing
RF connectors
Mounting position

Ordering code Q42-X4626

approx. 12.2 kg net, approx. 80 kg gross
approx. 588 mm × 135 mm × 170 mm
approx. 1190 mm × 790 mm × 800 mm
Flange UG 599/U, waveguide WR 28
any

Heating

Heater voltage	U_h	≈ 6	V ¹⁾
Heater current	I_h	≈ 1	A
Preheating time	t_h	≥ 5	min

indirectly heated by ac or dc (+ pole to cathode)
metal capillary cathode

Characteristics ($f = 27.5 \dots 29.5$ GHz)

		min	nom	max	
Power gain ($P_2 = 350$ W)	V_o	45			dB
VSWR at input	σ			2.0	²⁾ dB
Cold attenuation	α		80		dB

Operating characteristics

Frequency range	f	27.5 ... 29.5	GHz
Output power	P_2	350	W
Power gain	V_o	≥ 45	dB
Gain variation over the band	ΔV_o	≤ 2	dB ³⁾
Gain variation	$\Delta V_o / \Delta f$	≤ 1	dB/70 MHz ³⁾
Collector voltage	U_c	8.5 ... 9.5	kV ⁴⁾
Delay line voltage	U_d	17 ... 20	kV ⁴⁾
Grid 2 voltage	U_{G2}	U_{G1}	kV
Delay line current	I_d	≤ 12	mA
Cathode current	I_k	150 ... 190	mA
AM/PM conversion	K_p	≈ 5	°/dB ⁵⁾
3rd order intermodulation product (2×20 W)	σ_3	≈ 28	dB

¹⁾ If the maximum deviation of the heater voltage exceeds the actually set values of ±0.1 V, the operating performance of the tube will be impaired and its life shortened.

²⁾ With cold tube throughout the frequency band 27.5 to 29.5 GHz.

³⁾ At a load VSWR ≤ 1.2.

⁴⁾ The optimum setting value is indicated on the tube card, supplied with each tube.

⁵⁾ AM/PM conversion is the phase shift of the RF output signal, when changing the input power by 1 dB.

Maximum ratings (absolute values)

Collector voltage	U_C	max	12	kV
Collector voltage	U_C	min	8	kV
Collector dissipation	P_C	max	1.9	kW
Delay line voltage	U_H	max	20.5	kV
Delay line current	I_H	max	15	mA ¹⁾
Grid 2 voltage	U_{G2}	max	U_H	kV
Cathode current	I_k	max	200	mA
Load VSWR	S_L	max	2	
Ambient temperature	t_{amb}	min	-10	°C
Ambient temperature	t_{amb}	max	50	°C
Storage temperature	t_{stg}	min	-40	°C
Storage temperature	t_{stg}	max	75	°C
Height above mean sea level				

For general instructions, recommendations for designing a power supply, and detailed data refer to performance specifications.

¹⁾ Trip level for helix overcurrent protection circuit.

Cooling

A forced-air flow is used to dissipate the heat developed by the collector dissipation. The following cooling data applies to operation at mean sea level.

Air flow rate	4	m ³ /min
Pressure drop	≈ 5	mbar
Inlet temperature	max 45	°C

The temperature is monitored by the integrated thermal switch. The thermal switch has to be part of an interlock circuit which is provided to disconnect the tube upon exceeding the max. permissible temperature.

Backward wave oscillator with an electronic tuning range between 23 and 35 GHz at a minimum output power of 50 mW.

Fields of application are RF measuring systems, physical and chemical research as well as radar systems.



Backward wave oscillator RWO 35 S

Ordering code Q46-X3331

Weight
Dimensions of packing:

approx. 4.5 kg net, approx. 8.5 kg gross
approx. 430 mm × 390 mm × 375 mm

Heating

Heater voltage	U_F	6.3 ($\pm 2\%$)	V
Heater current	I_F	≈ 1	A
Preheating time indirectly heated by ac metal capillary dispenser cathode	t_w	≥ 120	s

Capacitances

$C_{g1/k, g2, g3, h}$	≈ 5.4	pF
$C_{g2/k, g1, g3, h}$	≈ 4.8	pF
$C_{g3/k, g1, g2, h}$	≈ 5.2	pF
$C_{h/k, g1, g2, g3}$	≈ 9.5	pF

Operating characteristics¹⁾

Frequency range	f	23 ... 35	GHz
Average output power	P_2	150	mW
Minimum output power	P_2	50	mW
Delay line voltage	U_w	500 ... 2600	V ²⁾
Grid 3 voltage	U_{G3}	≈ 200	V
Grid 2 voltage	U_{G2}	≈ 1500	V
Grid 1 voltage, negative	$-U_{G1}$	≈ 100	V
Grid 1 cutoff voltage ($P_2 = 0$)	$-U_{G1 \text{ cutoff}}$	≤ 300	V
Delay line current	I_H	≈ 12	mA
Grid 3 current	I_{G3}	≈ 0.5	mA
Grid 2 current	I_{G2}	≈ 0.8	mA

Maximum ratings (absolute values)

Delay line voltage	U_w	max	3000	V
Delay line dissipation	P_w	max	40	W
Grid 3 voltage	U_{G3}	max	500	V
Grid 3 dissipation	P_{G3}	max	1.5	W
Grid 2 voltage	U_{G2}	max	2500	V
Grid 2 dissipation	P_{G2}	max	3	W
Grid 1 voltage, negative	$-U_{G1}$	min	10	V
Grid 1 voltage, negative	$-U_{G1}$	max	600	V
Cathode current	I_k	max	15	mA
Ambient temperature	t_{amb}	min	-20	°C ³⁾
Ambient temperature	t_{amb}	max	55	°C ³⁾

¹⁾ A calibration curve supplied with each tube shows frequency and output power versus delay line voltage and exact operating values for grid 1, grid 2, and grid 3 voltages.

²⁾ Collector and delay line are electrically interconnected.

³⁾ For operation at ambient temperatures outside these limits please consult the manufacturer.

Operating instructions

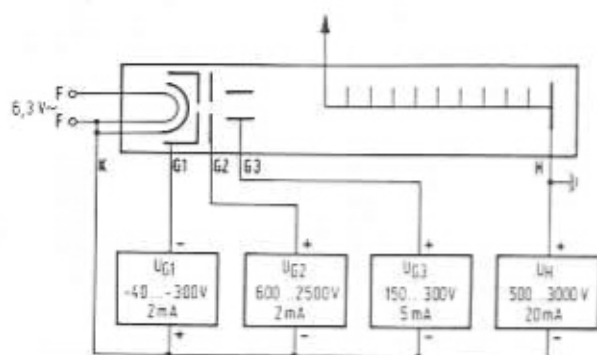

Stabilization of the operating voltages is necessary to obtain good frequency and performance stability. All electrode voltages have to be adjustable within the limits indicated in the circuit diagram. The delay line voltage (U_H) is used to set the required operating frequency of the oscillator.

The power supply has to be provided with the necessary trip circuits to protect the tube against overloading.

When mounting the oscillator, care should be taken to keep a spacing of at least 150 mm between the oscillator and ferromagnetic parts. In addition, adequate spacing to other magnetic fields is to be provided.

Modulation

The backward wave oscillator RWO 35 S may be operated with frequency modulation as well as with amplitude modulation by means of square-wave pulses.

In case of frequency modulation, the chosen modulation voltage is superimposed on the delay line voltage (U_H). The frequency swing can be adjusted by means of amplitude control of the modulation voltage.

For keying the tube positive or negative square wave pulses are superimposed on the grid 1 voltage. It has to be ensured that the permissible maximum ratings for the negative grid 1 voltage (10 V and 600 V) and the cathode current (15 mA) are not exceeded. The modulation voltage for cutting off the oscillator is given in the calibration curve supplied with each tube. The impedance of the voltage supplies for grid 2, grid 3 and delay line must be as low as possible in order to avoid an additional frequency modulation when keying the tube.

Cooling

To dissipate the heat, the tube must be cooled with an air flow rate of about 150 l/min.

Starting

Color code of leads:

F	:	brown
F	:	orange*)
G1	:	green
G2	:	blue
G3	:	red
H, ground:	:	black
K	:	yellow*)

*) Connect heater (orange) to cathode (yellow).

For starting the tube, the following turn-on sequence has absolutely to be kept (operating voltages for delay line, grid 3, grid 2, and grid 1 are indicated on the calibration curve of the tube).

1. Turn on air cooling.
2. Turn on heater voltage and preheat tube for at least 2 min. The grid 1, grid 3, and delay line voltages can be applied simultaneously with the heater voltage.
3. Turn on grid 2 voltage (U_{G2}) and adjust to the operating value.
4. Adjust tube to the required frequency by setting the delay line voltage (U_H) according to the calibration curve supplied with each tube.
5. Readjust grid 3 voltage (U_{G3}) to maximum RF power.

Turning off

1. Turn off grid 2 voltage (U_{g2}).
2. Turn off remaining electrode voltages.

On no account, the delay line voltage (U_{dl}) or the grid 3 voltage (U_{g3}) should be turned off first, since the tube may be damaged.

After an interruption of the tube for a longer period (about 6 months), it is recommended to preheat the tube for about 15 minutes prior to applying the full electrode voltages. Subsequently, the tube should be operated at a reduced delay line voltage (U_{dl}) of 600 to 800 V for at least 1 hour. The remaining electrode voltages have to be adjusted to the operating values.

Outline drawing RWO 35 S

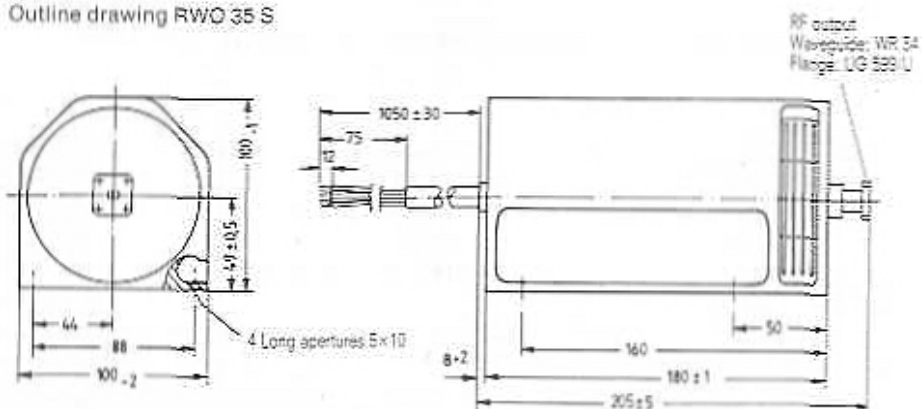

Dimensions in mm

Backward wave oscillator with an electronic tuning range between 33 and 50 GHz at a minimum output power of 30 mW.

Fields of application are RF measuring systems, physical and chemical research as well as radar systems.



Backward wave oscillator RWO 50 S

Ordering code Q46-X3328

Weight
Dimensions of packing

approx. 4.5 kg net, approx. 8.5 kg gross
approx. 430 mm × 390 mm × 375 mm

Heating

Heater voltage	U_h	6.3 ($\pm 2\%$)	V
Heater current	I_h	≈ 1	A
Preheating time indirectly heated by ac metal capillary dispenser cathode	t_s	≈ 120	s

Capacitances

$C_{g1/k, g2, g3, n}$	≈ 5.4	pF
$C_{g2/k, g1, g3, n}$	≈ 4.8	pF
$C_{g3/k, g1, g2, n}$	≈ 5.2	pF
$C_{nk, g1, g2, g3}$	≈ 9.5	pF

Operating characteristics¹⁾

Frequency range	f	33 ... 50	GHz
Average output power	P_2	100	mW
Minimum output power	P_2	30	mW
Delay line voltage	U_H	500 ... 2600	V ²⁾
Grid 3 voltage	U_{G3}	≈ 200	V
Grid 2 voltage	U_{G2}	≈ 1800	V
Grid 1 voltage, negative	$-U_{G1}$	≈ 200	V
Grid 1 cutoff voltage ($P_2 = 0$)	$-U_{G1 \text{ cutoff}}$	≤ 400	V
Delay line current	I_H	≈ 12	mA
Grid 3 current	I_{G3}	≈ 0.5	mA
Grid 2 current	I_{G2}	≈ 0.8	mA

Maximum ratings (absolute values)

Delay line voltage	U_H	max	3000	V
Delay line dissipation	P_H	max	40	W
Grid 3 voltage	U_{G3}	max	500	V
Grid 3 dissipation	P_{G3}	max	1.5	W
Grid 2 voltage	U_{G2}	max	2500	V
Grid 2 dissipation	P_{G2}	max	3	W
Grid 1 voltage, negative	$-U_{G1}$	min	10	V
Grid 1 voltage, negative	$-U_{G1}$	max	600	V
Cathode current	i_k	max	15	mA
Ambient temperature	t_{amb}	min	-20	$^{\circ}\text{C}^3)$
Ambient temperature	t_{amb}	max	55	$^{\circ}\text{C}^3)$

1) A calibration curve supplied with each tube shows frequency and output power versus delay line voltage and exact operating values for grid 1, grid 2, and grid 3 voltages.

2) Collector and delay line are electrically interconnected.

3) For operation at ambient temperatures outside these limits please consult the manufacturer.

Operating instructions

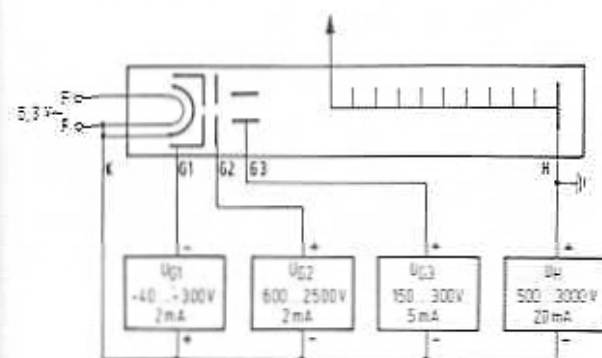

Stabilization of the operating voltages is necessary to obtain good frequency and performance stability. All electrode voltages have to be adjustable within the limits indicated in the circuit diagram. The delay line voltage (U_H) is used to set the required operating frequency of the oscillator.

The power supply has to be provided with the necessary trip circuits to protect the tube against overloading.

When mounting the oscillator, care should be taken to keep a spacing of at least 150 mm between the oscillator and ferromagnetic parts. In addition, adequate spacing to other magnetic fields is to be provided.

Modulation

The backward wave oscillator RWO 50 S may be operated with frequency modulation as well as with amplitude modulation by means of square-wave pulses.

In case of frequency modulation, the chosen modulation voltage is superimposed on the delay line voltage (U_d). The frequency swing can be adjusted by means of amplitude control of the modulation voltage.

For keying the tube positive or negative square wave pulses are superimposed on the grid 1 voltage. It has to be ensured that the permissible maximum ratings for the negative grid 1 voltage (10 V and 600 V) and the cathode current (15 mA) are not exceeded. The modulation voltage for cutting off the oscillator is given in the calibration curve supplied with each tube. The impedance of the voltage supplies for grid 2, grid 3 and delay line must be as low as possible in order to avoid an additional frequency modulation when keying the tube.

Cooling

To dissipate the heat, the tube must be cooled with an air flow rate of about 150 l/min.

Starting

Color code of leads:

F	:	brown
F	:	orange*)
G1	:	green
G2	:	blue
G3	:	red
H, ground:	:	black
K	:	yellow*)

*) Connect heater (orange) to cathode (yellow).

For starting the tube, the following turn-on sequence has absolutely to be kept (operating voltages for delay line, grid 3, grid 2, and grid 1 are indicated on the calibration curve of the tube).

1. Turn on air cooling.
2. Turn on heater voltage and preheat tube for at least 2 min. The grid 1, grid 3, and delay line voltages can be applied simultaneously with the heater voltage.
3. Turn on grid 2 voltage (U_{G2}) and adjust to the operating value.
4. Adjust tube to the required frequency by setting the delay line voltage (U_d) according to the calibration curve supplied with each tube.
5. Readjust grid 3 voltage (U_{G3}) to maximum RF power.

Turning off

1. Turn off grid 2 voltage (U_{G2}).
2. Turn off remaining electrode voltages.

On no account, the delay line voltage (U_d) or the grid 3 voltage (U_{G3}) should be turned off first, since the tube may be damaged.

After an interruption of the tube for a longer period (about 6 months), it is recommended to preheat the tube for about 15 minutes prior to applying the full electrode voltages. Subsequently, the tube should be operated at a reduced delay line voltage (U_d) of 600 to 800 V for at least 1 hour. The remaining electrode voltages have to be adjusted to the operating values.

Outline drawing RWO 50 S

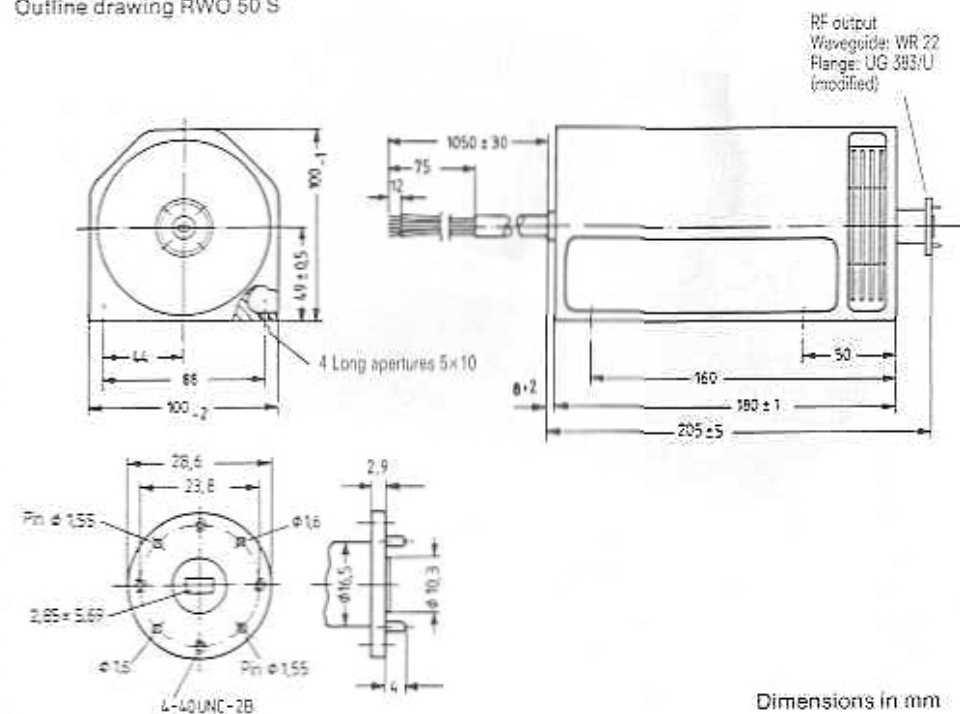

Dimensions in mm

Backward wave oscillator with an electronic tuning range between 50 and 75 GHz at a minimum output power of 10 mW.

Fields of application are RF measuring systems, physical and chemical research as well as radar systems.



Backward wave oscillator RWO 75 S

Ordering code Q46-X3323

Weight
Dimensions of packing

approx. 4.5 kg net, approx. 8.5 kg gross
approx. 430 mm × 390 mm × 375 mm

Heating

Heater voltage	U_F	6.3 (±2%)	V
Heater current	I_F	≈ 1	A
Preheating time	t_h	≥ 120	s

indirectly heated by ac metal capillary dispenser cathode

Capacitances

$C_{g3/k, g1, g2, H}$	≈ 5.4	pF
$C_{g2/k, g1, g3, H}$	≈ 4.8	pF
$C_{g3/k, g1, g2, H}$	≈ 5.2	pF
$C_{H/k, g1, g2, g3}$	≈ 9.5	pF

Operating characteristics¹⁾

Frequency range	f	50 ... 75	GHz
Average output power	P_2	40	mW
Minimum output power	P_2	10	mW
Delay line voltage	U_H	500 ... 2600	V ²⁾
Grid 3 voltage	U_{G3}	≈ 200	V
Grid 2 voltage	U_{G2}	≈ 1800	V
Grid 1 voltage, negative	$-U_{G1}$	≈ 200	V
Grid 1 cutoff voltage ($P_2 = 0$)	$-U_{G1, cut off}$	≤ 400	V
Delay line current	I_H	≈ 12	mA
Grid 3 current	I_{G3}	≈ 0.5	mA
Grid 2 current	I_{G2}	≈ 0.8	mA

Maximum ratings (absolute values)

Delay line voltage	U_H	max	3000	V
Delay line dissipation	P_H	max	40	W
Grid 3 voltage	U_{G3}	max	500	V
Grid 3 dissipation	P_{G3}	max	1.5	W
Grid 2 voltage	U_{G2}	max	2500	V
Grid 2 dissipation	P_{G2}	max	3	W
Grid 1 voltage, negative	$-U_{G1}$	min	10	V
Grid 1 voltage, negative	$-U_{G1}$	max	600	V
Cathode current	I_K	max	15	mA
Ambient temperature	t_{amb}	min	-20	°C ³⁾
Ambient temperature	t_{amb}	max	55	°C ³⁾

¹⁾ A calibration curve supplied with each tube shows frequency and output power versus delay line voltage and exact operating values for grid 1, grid 2, and grid 3 voltages.

²⁾ Collector and delay line are electrically interconnected.

³⁾ For operation at ambient temperatures outside these limits please consult the manufacturer.

Operating instructions

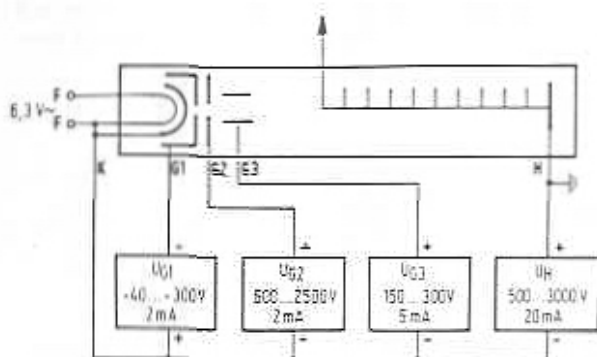

Stabilization of the operating voltages is necessary to obtain good frequency and performance stability. All electrode voltages have to be adjustable within the limits indicated in the circuit diagram. The delay line voltage (U_H) is used to set the required operating frequency of the oscillator.

The power supply has to be provided with the necessary trip circuits to protect the tube against overloading.

When mounting the oscillator, care should be taken to keep a spacing of at least 150 mm between the oscillator and ferromagnetic parts. In addition, adequate spacing to other magnetic fields is to be provided.

Modulation

The backward wave oscillator RWO 75 S may be operated with frequency modulation as well as with amplitude modulation by means of square-wave pulses.

In case of frequency modulation, the chosen modulation voltage is superimposed on the delay line voltage (U_H). The frequency swing can be adjusted by means of amplitude control of the modulation voltage.

For keying the tube positive or negative square wave pulses are superimposed on the grid 1 voltage. It has to be ensured that the permissible maximum ratings for the negative grid 1 voltage (10 V and 600 V) and the cathode current (15 mA) are not exceeded. The modulation voltage for cutting off the oscillator is given in the calibration curve supplied with each tube. The impedance of the voltage supplies for grid 2, grid 3 and delay line must be as low as possible in order to avoid an additional frequency modulation when keying the tube.

Cooling

To dissipate the heat, the tube must be cooled with an air flow rate of about 150 l/min.

Starting

Color code of leads:

F	:	brown
F	:	orange*)
G1	:	green
G2	:	blue
G3	:	red
H, ground:	:	black
K	:	yellow*)

*) Connect heater (orange) to cathode (yellow).

For starting the tube, the following turn-on sequence has absolutely to be kept (operating voltages for delay line, grid 3, grid 2, and grid 1 are indicated on the calibration curve of the tube).

1. Turn on air cooling.
2. Turn on heater voltage and preheat tube for at least 2 min. The grid 1, grid 3, and delay line voltages can be applied simultaneously with the heater voltage.
3. Turn on grid 2 voltage (U_{G2}) and adjust to the operating value.
4. Adjust tube to the required frequency by setting the delay line voltage (U_H) according to the calibration curve supplied with each tube.
5. Readjust grid 3 voltage (U_{G3}) to maximum RF power.

Heating

Heater voltage	U_c	6.3 ($\pm 2\%$)	V
Heater current	I_c	≈ 1	A
Preheating time indirectly heated by ac metal capillary dispenser cathode	t_h	≥ 120	s

Capacitances

$C_{g1/k, g2, g3, h}$	≈ 5.4	pF
$C_{g2/k, g1, g3, h}$	≈ 4.8	pF
$C_{g3/k, g1, g2, h}$	≈ 5.2	pF
$C_{h/k, g1, g2, g3}$	≈ 9.5	pF

Operating characteristics¹⁾

Frequency range	f	75 ... 110	GHz
Average output power	P_2	20	mW
Minimum output power	P_2	5	mW
Delay line voltage	U_H	500 ... 2600	V ²⁾
Grid 3 voltage	U_{G3}	≈ 250	V
Grid 2 voltage	U_{G2}	≈ 2000	V
Grid 1 voltage, negative	$-U_{G1}$	≈ 250	V
Grid 1 cutoff voltage ($P_1 = 0$)	$-U_{G1 \text{ cutoff}}$	≤ 450	V
Delay line current	I_H	≈ 12	mA
Grid 3 current	I_{G3}	≈ 0.5	mA
Grid 2 current	I_{G2}	≈ 0.8	mA

Maximum ratings (absolute values)

Delay line voltage	U_H	max	3000	V
Delay line dissipation	P_H	max	40	W
Grid 3 voltage	U_{G3}	max	500	V
Grid 3 dissipation	P_{G3}	max	1.5	W
Grid 2 voltage	U_{G2}	max	3000	V
Grid 2 dissipation	P_{G2}	max	3	W
Grid 1 voltage, negative	$-U_{G1}$	min	10	V
Grid 1 voltage, negative	$-U_{G1}$	max	600	V
Cathode current	I_c	max	15	mA
Ambient temperature	t_{amb}	min	-20	°C ³⁾
Ambient temperature	t_{amb}	max	55	°C ³⁾

¹⁾ A calibration curve supplied with each tube shows frequency and output power versus delay line voltage and exact operating values for grid 1, grid 2, and grid 3 voltages.

²⁾ Collector and delay line are electrically interconnected.

³⁾ For operation at ambient temperatures outside these limits please consult the manufacturer.

Operating instructions

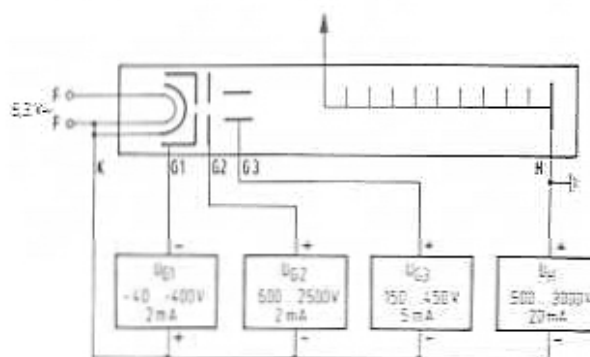

Stabilization of the operating voltages is necessary to obtain good frequency and performance stability. All electrode voltages have to be adjustable within the limits indicated in the circuit diagram. The delay line voltage (U_H) is used to set the required operating frequency of the oscillator.

The power supply has to be provided with the necessary trip circuits to protect the tube against overloading.

When mounting the oscillator, care should be taken to keep a spacing of at least 150 mm between the oscillator and ferromagnetic parts. In addition, adequate spacing to other magnetic fields is to be provided.

Modulation

The backward wave oscillator RWO 110 S may be operated with frequency modulation as well as with amplitude modulation by means of square-wave pulses.

In case of frequency modulation, the chosen modulation voltage is superimposed on the delay line voltage (U_d). The frequency swing can be adjusted by means of amplitude control of the modulation voltage.

For keying the tube positive or negative square wave pulses are superimposed on the grid 1 voltage. It has to be ensured that the permissible maximum ratings for the negative grid 1 voltage (10 V and 600 V) and the cathode current (15 mA) are not exceeded. The modulation voltage for cutting off the oscillator is given in the calibration curve supplied with each tube. The impedance of the voltage supplies for grid 2, grid 3 and delay line must be as low as possible in order to avoid an additional frequency modulation when keying the tube.

Cooling

To dissipate the heat, the tube must be cooled with an air flow rate of about 150 l/min.

Starting

Color code of leads:

F	:	brown
F	:	orange*)
G1	:	green
G2	:	blue
G3	:	red
H, ground:	:	black
K	:	yellow*)

*) Connect heater (orange) to cathode (yellow).

For starting the tube, the following turn-on sequence has absolutely to be kept (operating voltages for delay line, grid 3, grid 2, and grid 1 are indicated on the calibration curve of the tube).

1. Turn on air cooling.
2. Turn on heater voltage and preheat tube for at least 2 min. The grid 1, grid 3, and delay line voltages can be applied simultaneously with the heater voltage.
3. Turn on grid 2 voltage (U_{G2}) and adjust to the operating value.
4. Adjust tube to the required frequency by setting the delay line voltage (U_d) according to the calibration curve supplied with each tube.
5. Readjust grid 3 voltage (U_{G3}) to maximum RF power.

Turning off

1. Turn off grid 2 voltage (U_{G2}).
2. Turn off remaining electrode voltages.

On no account, the delay line voltage (U_d) or the grid 3 voltage (U_{G3}) should be turned off first, since the tube may be damaged.

After an interruption of the tube for a longer period (about 6 months), it is recommended to preheat the tube for about 15 minutes prior to applying the full electrode voltages. Subsequently, the tube should be operated at a reduced delay line voltage (U_d) of 600 to 800 V for at least 1 hour. The remaining electrode voltages have to be adjusted to the operating values.

Outline drawing RWO 110 S

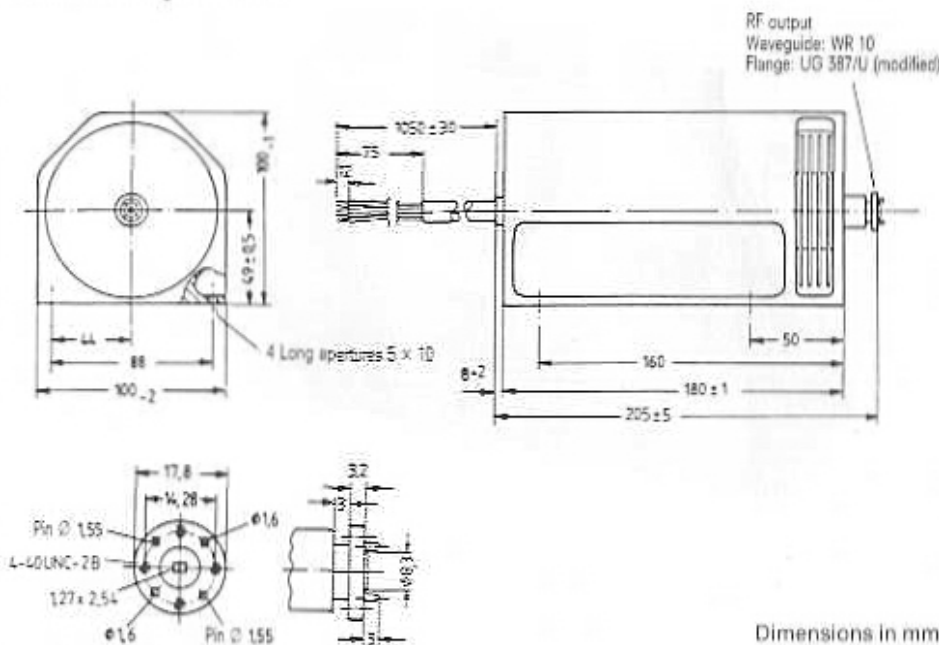

Dimensions in mm

Backward wave oscillator with an electronic tuning range between 110 and 170 GHz at a minimum output power of 1 mW.

Fields of application are RF measuring systems, physical and chemical research as well as radar systems.



Backward wave oscillator RWO 170

Ordering code Q46-X3330

Weight
Dimensions of packing:

approx. 4.5 kg net, approx. 8.5 kg gross
approx. 430 mm × 390 mm × 375 mm

Heating

Heater voltage	U_h	6.3 (±2%)	V
Heater current	I_h	≈ 1	A
Preheating time	t_h	≈ 120	s

indirectly heated by ac
metal capillary dispenser cathode

Capacitances

$C_{g3k, g2, g3, h}$	≈ 5.4	pF
$C_{g2k, g1, g3, h}$	≈ 4.8	pF
$C_{g1k, g1, g2, h}$	≈ 5.2	pF
$C_{k, g1, g2, g3}$	≈ 9.5	pF

Operating characteristics¹⁾

Frequency range	f	110 ... 170	GHz
Average output power	P_e	10	mW
Minimum output power	P_e	1	mW
Delay line voltage	U_d	500 ... 2800	V ²⁾
Grid 3 voltage	U_{G3}	≈ 350	V
Grid 2 voltage	U_{G2}	≈ 2500	V
Grid 1 voltage, negative	$-U_{G1}$	≈ 300	V
Grid 1 cutoff voltage ($P_e = 0$)	$-U_{G1, cutoff}$	≤ 500	V
Delay line current	I_d	≈ 12	mA
Grid 3 current	I_{G3}	≈ 0.5	mA
Grid 2 current	I_{G2}	≈ 1	mA

Maximum ratings (absolute values)

Delay line voltage	U_d	max	3000	V
Delay line dissipation	P_d	max	40	W
Grid 3 voltage	U_{G3}	max	500	V
Grid 3 dissipation	P_{G3}	max	1.5	W
Grid 2 voltage	U_{G2}	max	3000	V
Grid 2 dissipation	P_{G2}	max	4	W
Grid 1 voltage, negative	$-U_{G1}$	min	10	V
Grid 1 voltage, negative	$-U_{G1}$	max	600	V
Cathode current	I_k	max	15	mA
Ambient temperature	t_{amb}	min	-20	°C ³⁾
Ambient temperature	t_{amb}	max	55	°C ³⁾

¹⁾ A calibration curve supplied with each tube shows frequency and output power versus delay line voltage and exact operating values for grid 1, grid 2, and grid 3 voltages.

²⁾ Collector and delay line are electrically interconnected.

³⁾ For operation at ambient temperatures outside these limits please consult the manufacturer.

Operating Instructions

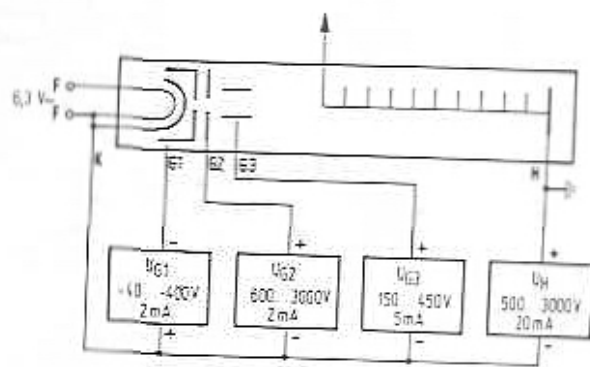

Stabilization of the operating voltages is necessary to obtain good frequency and performance stability. All electrode voltages have to be adjustable within the limits indicated in the circuit diagram. The delay line voltage (U_H) is used to set the required operating frequency of the oscillator.

The power supply has to be provided with the necessary trip circuits to protect the tube against overloading.

When mounting the oscillator, care should be taken to keep a spacing of at least 150 mm between the oscillator and ferromagnetic parts. In addition, adequate spacing to other magnetic fields is to be provided.

Modulation

The backward wave oscillator RWO 170 may be operated with frequency modulation as well as with amplitude modulation by means of square-wave pulses.

In case of frequency modulation, the chosen modulation voltage is superimposed on the delay line voltage (U_H). The frequency swing can be adjusted by means of amplitude control of the modulation voltage.

For keying the tube positive or negative square wave pulses are superimposed on the grid 1 voltage. It has to be ensured that the permissible maximum ratings for the negative grid 1 voltage (10 V and 600 V) and the cathode current (15 mA) are not exceeded. The modulation voltage for cutting off the oscillator is given in the calibration curve supplied with each tube. The impedance of the voltage supplies for grid 2, grid 3 and delay line must be as low as possible in order to avoid an additional frequency modulation when keying the tube.

Cooling

To dissipate the heat, the tube must be cooled with an air flow rate of about 150 l/min.

Starting

Color code of leads:

F	:	brown
F	:	orange*)
G1	:	green
G2	:	blue
G3	:	red
H, ground:	:	black
K	:	yellow*)

*) Connect heater (orange) to cathode (yellow).

For starting the tube, the following turn-on sequence has absolutely to be kept (operating voltages for delay line, grid 3, grid 2, and grid 1 are indicated on the calibration curve of the tube).

1. Turn on air cooling.
2. Turn on heater voltage and preheat tube for at least 2 min. The grid 1, grid 3, and delay line voltages can be applied simultaneously with the heater voltage.
3. Turn on grid 2 voltage (U_{G2}) and adjust to the operating value.
4. Adjust tube to the required frequency by setting the delay line voltage (U_H) according to the calibration curve supplied with each tube.
5. Readjust grid 3 voltage (U_{G3}) to maximum RF power.

Turning off

1. Turn off grid 2 voltage (U_{G2}).
2. Turn off remaining electrode voltages.

On no account, the delay line voltage (U_{DL}) or the grid 3 voltage (U_{G3}) should be turned off first, since the tube may be damaged.

After an interruption of the tube for a longer period (about 6 months), it is recommended to preheat the tube for about 15 minutes prior to applying the full electrode voltages. Subsequently, the tube should be operated at a reduced delay line voltage (U_{DL}) of 600 to 800 V for at least 1 hour. The remaining electrode voltages have to be adjusted to the operating values.

Outline drawing RWO 170

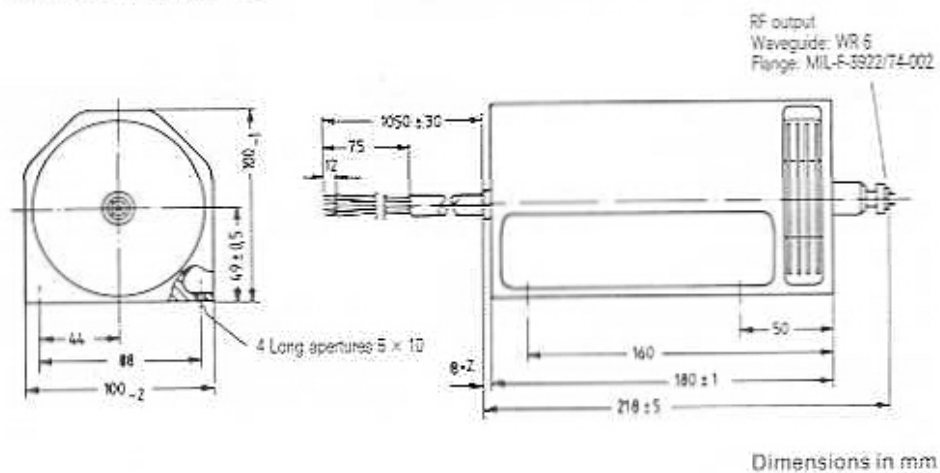

Siemens Worldwide
(Addresses)

Siemens AG, Bereich Bauelemente
Balanstraße 73, Postfach 8017 09, **D-8000 München 80**
☎ (089) 41 44-0 ☐ 52 108-0 FAX (089) 41 44-26 89

Siemens Worldwide

Federal Republic of Germany and Berlin (West)

Siemens AG
Salzhofer 6-8
1000 Berlin 10
☎ (030) 3939-1, ☐ 1810-278
FAX (030) 3939-2630
Tx 308190 — sieznb

Siemens AG
Contrescarpe 72
Postfach 107827
2800 Bremen
☎ (0421) 364-0, ☐ 245451
FAX (0421) 364-2687

Siemens AG
Lahnweg 10
Postfach 1115
4000 Düsseldorf 1
☎ (0211) 399-0, ☐ 8581301
FAX (0211) 399-2506

Siemens AG
Rödelheimer Landstraße 5-9
Postfach 111733
6000 Frankfurt 1
☎ (069) 797-0, ☐ 41 41 31
FAX (069) 797-2253

Siemens AG
Lindenplatz 2
Postfach 105609
2000 Hamburg 1
☎ (040) 262-1, ☐ 215584-0
FAX (040) 262-2210

Siemens AG
Am Maschpark 1
Postfach 5329
3000 Hannover 1
☎ (0511) 129-0, ☐ 922333
FAX (0511) 129-2799

Siemens AG
Richard-Strauss-Straße 76
Postfach 202109
8000 München
☎ (089) 9221-0
☐ 529421-19
FAX (089) 9221-4390

Siemens AG
Von-der-Tann-Straße 30
Postfach 4844
8500 Nürnberg 1
☎ (0911) 654-0, ☐ 622251
FAX (0911) 654-3436, 3464

Siemens AG
Geschwister-Scholl-Straße 24
Postfach 120
7000 Stuttgart 1
☎ (0711) 2076-1, ☐ 723941
FAX (0711) 2076-706

EUROPE

Austria

Siemens Aktiengesellschaft
Österreich
Postfach 326
A-1031 Wien
☎ (0222) 7293-0, ☐ 1372-0

Belgium

Siemens S.A.
chaussée de Charleroi 116
B-1060 Bruxelles
☎ (02) 536 2111, ☐ 21347

Denmark

Siemens A/S
Borupvang 3
DK-2750 Ballerup
☎ (02) 656665, ☐ 35313

Finland

Siemens Osakeyhtiö
Fach 8
SF-00101 Helsinki 10
☎ (0) 1626-1, ☐ 124406

France

Siemens S.A.
B.P. 109
F-93203 Saint-Denis CEDEX 1
☎ (1) 8206120, ☐ 620853

Great Britain

Siemens Ltd
Siemens House
Windmill Road
GB-Sunbury-on-Thames
Middlesex TW 16 7HS
☎ (09327) 85691, ☐ 8951091

Greece

Siemens A.E.
Voulas 7
P.O.B. 3601
GR-10247 Athen
☎ (01) 3293-1, ☐ 216291

Ireland

Siemens Ltd.
Unit B-11 Slaney Road
Dublin Industrial Estate
Finglas Road
Dublin 11
☎ (01) 302856, ☐ 24129

Italy

Siemens Elettra S.p.A.
Via Fabio Filzi, 29
Casella Postale 10388
I-20100 Milano
☎ (02) 67661, ☐ 330261

Netherlands

Siemens Nederland NV
Postb. 16086
NL-2500 BB Den Haag
☎ (070) 782782, ☐ 31373

Norway

Siemens A/S
Satre Aker vei 90
Postboks 10, Veitvet
N-0518 Oslo 5
☎ (02) 153090, ☐ 18477

Portugal

Siemens S.A.R.L.
Avenida Almirante Reis, 65
Apartado 1380
P-1100 Lisboa-1
☎ (01) 538805, ☐ 12563

Spain

Siemens S.A.
Orense, 2
Apartado 155
E-28080 Madrid
☎ (01) 4552500, ☐ 43320

Sweden

Siemens AB
Hälsingegatan 40
Box 23141
S-10435 Stockholm
☎ (08) 161-100, ☐ 19880

Switzerland

Siemens-Albis AG
Freitagstraße 26
Postfach
CH-8047 Zürich
☎ (01) 495-3111, ☐ 558911

Turkey

ETMAS Elektrik Tesisatı ve
Mühendislik A.Ş.
Meclis Mebusan Caddesi 55/35
Fındıklı
PK. 1001 Karaköy
Istanbul
☎ 009011452090, ☐ 24233

AFRICA

South African Republic

Siemens Limited
Siemens House,
P.O.B. 4583
2000 Johannesburg
☎ (011) 7159111, ☐ 4-02624

AMERICA

Argentina

Siemens S.A.
Avenida Pte. Julio A. Roca 516
Casilla Correo Central 1232
RA-1000 Buenos Aires
☎ (01) 00541/300411, ☐ 21812

Brazil

Siemens S.A.
Sede Central
Caixa Postal 1375,
01051 São Paulo-SP
☎ (011) 833-2211
☐ 11-29641

Canada

Siemens Electric Limited
7300 Trans-Canada Highway
P.O.B. 7300, Pointe Claire,
Quebec H9R 4R6
☎ (514) 6957300,
☐ 05822778

U.S.A.

Power semiconductors:
Siemens Components, Inc.
Colorado Components Division
800 Hoyt Street
Brookfield, Colorado 80020
☎ (303) 469-2161
☐ 454357 sie colo

Intelligent displays:

Siemens Components, Inc.
Optoelectronic Division
19000 Homestead Road
Cupertino, California 95014
☎ (408) 267-7910
☐ 352084 sie int opto

All other products:

Siemens Components, Inc.
Special Electronics Division
186 Wood Avenue South
Iselin, New Jersey 08830
☎ (201) 321-3400
☐ 844491

ASIA

Hongkong

Johnson & Co., Ltd.
Siemens Division
P.O.B. 97
Hongkong
☎ (05) 8233777, ☐ 73221

India

Siemens India Ltd.
Head Office
134-A, Dr. Annie Besant Road,
Worli
P.O.B. 6697
Bombay 400018
☎ 4938786, ☐ 75142

Japan

Fuji Electronic Components Ltd.
New Yurakucho Bldg., 8F
12-1, Yurakucho 1-Chome,
Chiyoda-ku
Tokyo 100
☎ (03) 201-2401, ☐ 32182

Korea

Siemens Electrical
Engineering Co., Ltd.
C.P.O.B. 3001
Seoul
☎ (02) 275-6111, ☐ 23229

Singapore

Siemens Components Pte. Ltd.
Promotion Office
10-15 E, 5th floor
47 Ayer Rajah Crescent No. 06-12
Singapore 0513
☎ 7760044, ☐ RS 21000

Taiwan

Iai Engineering Co. Ltd.
6th Floor Central Building
108, Chung Shan N. Rd. Sec. 2
PO Box 68-1882
Taipei
☎ 5363171, ☐ 27880

AUSTRALIA

Siemens Ltd.
514 Church Street, Richmond
Melbourne, Vic. 3121
☎ (03) 4207111, ☐ 30426

**Table of Contents
Summary of Types**

Index of Symbols

**Explanation of Technical Data
General Instructions and Operation**

**Power Traveling Wave Tubes
for Radio Link Systems**

**Power Supplies
for Radio Link TWTs**

**High Power TWTs
for Satellite Earth Stations,
TV and Troposcatter Transmitters**

Backward Wave Oscillators

**Siemens Worldwide
(Addresses)**

Ordering No. 05-B3422-X-X-7000
Printed in Germany
DB 05862